

SALINAS VALLEY HISTORICAL BENEFITS ANALYSIS (HBA)

FINAL REPORT
APRIL 1998



AR 07017



MONTGOMERY WATSON

IN PARTNERSHIP WITH CHAMBERLAIN
AND WHEELER ASSOCIATES



MONTGOMERY WATSON

April 3, 1998

Monterey County Water Resources Agency
893 Blanco Circle
Salinas, CA 93901

Attn: Mr. Michael Armstrong, General Manager

Dear Mr. Armstrong:

We are pleased to submit to you the executive summary and final report on the Historical Benefits Analysis (HBA). The HBA has been an innovative and challenging project for us, and we are excited that this report will contribute to the overall planning of the basin management in Salinas Valley.

The report presents the direct benefits that have been realized throughout the Valley due to the operation of Nacimiento and San Antonio Reservoirs. The benefits have been divided into *hydrologic*, *flood control*, and *economic* categories.

Section 1 of the report discusses the hydrologic and water supply benefits, including the impacts that the operation of reservoirs has had on increased ground water levels and lower pumping lifts, as well as reduction in seawater intrusion.

Section 2 discusses the impacts of the reservoir operations on the reduction in magnitude and frequency of floods that would have occurred in the Valley, had the reservoirs not been constructed.

Section 3 of the report presents the economic equivalence of the hydrologic and flood control benefits due to the operation of the reservoirs, along with other indirect benefits.

We appreciate the opportunity to work on this project with you and your staff.

Sincerely yours,

MONTGOMERY WATSON AMERICAS, INC.

S. Ali Taghavi, Ph.D, PE
Project Manager

177 Campus Commons
Suite 250
Sacramento, California
95825-3208

Tel: 916 924 8844
Fax: 916 924 9102

Serving the World's Environmental Needs

AR 07018

Table of Contents

EXECUTIVE SUMMARY

SECTION 1 - HYDROLOGIC BENEFITS ANALYSIS

| | |
|--------------------------------------------------------------------------------|------|
| Background | 1-1 |
| Hydrologic Setting | 1-1 |
| Historical Reservoir Operations | 1-2 |
| Salinas Valley Hydrogeology | 1-3 |
| Salinas Valley Integrated Ground Water and Surface Water Model | 1-5 |
| Historical Benefits Analysis | 1-6 |
| Approach to Impact Analysis | 1-6 |
| Comparison of Simulations Historical and Without Reservoir Conditions | 1-7 |
| Ground Water Balances | 1-8 |
| Ground Water Levels | 1-10 |
| Determination of Impacts on Ground Water Levels | 1-10 |
| Development of Economic Study Unit Boundaries | 1-12 |
| Changes in Regional Average Ground Water Levels | 1-13 |
| Impacts on Well Performance | 1-13 |
| Hydrologic Impact on Wells | 1-14 |
| Seawater Intrusion Impacts | 1-17 |
| Regional Ground Water Quality | 1-20 |
| Hydrologic Impacts Under Baseline Conditions | 1-21 |
| Baseline Analysis | 1-21 |
| Ground Water Levels | 1-22 |
| Seawater Intrusion | 1-23 |

SECTION 2 - FLOOD CONTROL BENEFITS ANALYSIS

| | |
|-------------------------------------------------------|------|
| Background | 2-1 |
| River Reaches | 2-1 |
| Purpose | 2-1 |
| Study Plan | 2-2 |
| Flood Control Hydrology | 2-3 |
| Flow Data | 2-3 |
| Durations | 2-3 |
| Statistical Analyses | 2-4 |
| Conclusions of Flood Control Hydrology Analysis | 2-6 |
| Hydraulics and Floodplain Mapping | 2-8 |
| Base Mapping | 2-8 |
| Roughness Calibration | 2-9 |
| Levees | 2-9 |
| HEC-2 Models | 2-11 |
| Erosivity | 2-12 |
| Floodplain Mapping | 2-13 |
| Conclusions | 2-14 |

SECTION 3 - ECONOMIC BENEFIT ANALYSIS

Introduction 3-1

Water Supply Benefits..... 3-2

 Approach to Analysis 3-2

 Avoided Costs for Ground Water Pumping 3-2

 Avoided Cost from Drilling New Wells or Modifying Existing Wells 3-4

 Avoided Well Cost from Seawater Intrusion 3-6

 Summary of Water Supply Benefits 3-7

Flood Control Benefits 3-10

 Prevention of Agricultural Damages 3-10

 Physical Data Inputs 3-11

 Farm Income Losses 3-11

 Agricultural Repair Costs 3-13

 Prevention of Damages to Buildings and Structures 3-18

 Methodology 3-18

 Building Inventory 3-19

 Flood Control Benefits to Buildings and Structures 3-21

Other Unquantified Benefits of the Reservoirs 3-21

 Ground Water Quality Benefits Outside of the Intrusion Area 3-23

 Value of Good Quality Ground Water in Storage 3-23

 Value of the Ground Water Basin for Storage and Distribution 3-23

 Value of the Reservoirs as Insurance against Rainfall Variation 3-24

 Recreational and Environmental Benefits 3-24

 Other Indirect Benefits 3-24

SECTION 4 - REFERENCES

SECTION 5 - GLOSSARY OF TERMS

SECTION 6 - PROJECT TEAM

APPENDICES (BOUND AS SEPARATE VOLUME)

APPENDIX A - SVIGSM Model Extension and Verification

APPENDIX B - Supporting Information for Flood Control Benefits Analysis

APPENDIX C - Supporting Information for Economic Benefits Analysis

LIST OF TABLES

Table ES-1 Impact of Historical Operations of Reservoirs on Ground Water Levels . ES-5
 Table ES-2 Summary of Water Supply Economic Benefits by ESU ES-9
 Table ES-3 Summary of Flood Control Economic Benefits by FSU ES-11
 Table 1-1 SVIGSM Data Set Updates for the Historical Benefits Analysis 1-8
 Table 1-2 Regional Average Annual Ground Water Levels Long-Term Average,
 1958-1994..... 1-15
 Table 1-3 Estimated Well Drawdowns 1-15
 Table 1-4 Summary of Detailed Well Performance Analysis 1-17
 Table 1-5 Summary of Well Performance Impact Analysis 1-18
 Table 1-6 Ground Water Flow Velocities in the Upper Valley 1-22
 Table 2-1 Salinas River - With and Without Reservoirs Discharge-Probability
 Comparison 2-7
 Table 2-2 Channel Capacity Results 2-12
 Table 2-3 Erosion Potential Index Criteria 2-14
 Table 3-1 Annual Avoided Ground Water Pumping Cost by ESU 1958-1994 Average 3-3
 Table 3-2 Annual Avoided Well Cost from Drilling New Wells to Modifying Wells by
 ESU 3-5
 Table 3-3 Hydrologic Subareas and Economic Study Units (ESU) 3-5
 Table 3-4 Detailed Calculation of Avoided Cost of Drilling New Wells: ESU 9 3-6
 Table 3-5 Detailed Calculation of Avoided Cost of Modifying Wells: ESU 1 3-7
 Table 3-6 Annual Avoided Well Cost Due to Seawater Intrusion by ESU in 1994 3-8
 Table 3-7 Detailed Calculation of Avoided Well Cost due to Seawater Intrusion:
 180-foot Aquifer, ESU 1 3-9
 Table 3-8 Detailed Calculation of Avoided Well Cost Due to Seawater Intrusion, 400-
 foot Aquifer, ESU 1 3-9
 Table 3-9 Summary of Water Supply Benefits by ESU..... 3-10
 Table 3-10 Crop Mix of Area Flooded, "With" and "Without" Reservoirs 3-12
 Table 3-11 Farm Income Losses on Additional Acreage Damaged (in dollars
 per acre) 3-15
 Table 3-12 1995 ECP Costs and Other Repair Costs Counted..... 3-15
 Table 3-13 Erosivity and Repair Costs for Additional Acreage Flooded Without
 Reservoirs, (100-Year Event) 3-16
 Table 3-14 Increased Erosivity of Land in 100-Year Floodplain with Reservoirs and
 Associated Costs..... 3-18
 Table 3-15 Economic Benefits from Prevention of Agricultural Damage by ESU 3-19
 Table 3-16 Buildings and Structures Located in 100-year Without Reservoirs Flood
 Plain, Salinas Valley 3-20
 Table 3-17 Damages and Lost Incomes and Services Without Reservoirs , Salinas
 Valley 3-22
 Table 3-18 Damages and Lost Incomes and Services With Reservoirs, Salinas
 Valley 3-22
 Table 3-19 Economic Benefits of Flood Control for Buildings and Structures, Salinas
 Valley 3-22

| LIST OF FIGURES | Follows Page |
|--------------------------------------------------------------------------------------------------------------------------------------------------------------------------------|--------------|
| Figure ES-1 Study Area Map | ES-2 |
| Figure ES-2 Average Increase in Ground Water Levels, Historical vs. Without Reservoirs Simulation (1958-1994) | ES-3 |
| Figure ES-3 Economic Study Unit Boundaries | ES-4 |
| Figure ES-4 Cumulative and Annual Volume of Seawater Intrusion into the Pressure Subarea (Simulated Flow Across the Coastline) | ES-6 |
| Figure ES-5 Annual Peak Discharges at Selected Long-Term U.S. Geological Survey Gaging Stations | ES-7 |
| Figure ES-6 Flood Study Unit Boundaries | ES-8 |
| Figure 1-1 Subarea Map | 1-3 |
| Figure 1-2 Average Annual Ground Water Balance for the Salinas Valley Water Years 1958-1994 Historical Simulation (Values Rounded to the Nearest Thousands of Acre-Feet) | 1-9 |
| Figure 1-3 Average Annual Ground Water Balance by Subarea Water Years 1958-1994 Without Reservoir Simulation (Values Rounded to Nearest Thousands of Acre-Feet) | 1-9 |
| Figure 1-4 Average Annual Ground Water Balance by Subarea Water Years 1958-1994 Historical Simulation (Values Rounded to Nearest Thousands of Acre-Feet) | 1-9 |
| Figure 1-5 Average Annual Ground Water Balance by Subarea Water Years 1958-1994 Without Reservoir Simulation (Values Rounded to Nearest Thousands Acre-Feet) | 1-9 |
| Figure 1-6 Average Increase in Ground Water Levels, Historical vs. Without Reservoirs Simulation (1958-1994) | 1-9 |
| Figure 1-7 Average Monthly Pumping Distribution Weighting Factor | 1-10 |
| Figure 1-8 Average Monthly Salinas River Flows at Bradley 1958-1994 | 1-11 |
| Figure 1-9 Average Monthly Salinas River Flows at Soledad 1958-1994 | 1-11 |
| Figure 1-10 Average Monthly Salinas River Flows at Spreckels | 1-11 |
| Figure 1-11 Cumulative Volume of Stream Recharge in the Salinas Valley | 1-11 |
| Figure 1-12 Cumulative Salinas River Outflow (Simulated Flow at Spreckels) | 1-11 |
| Figure 1-13 Economic Study Unit Boundaries | 1-11 |
| Figure 1-14 - 1-23 Regional Average Annual Ground Water Levels for ESUs 1 - 10 .. | 1-13 |
| Figure 1-24 Location of Sample Wells Used for Impact Analysis | 1-14 |
| Figure 1-25 - 1-28 Well Perforations and Monthly Ground Water Levels Wells #1 - #4, Pressure Subarea | 1-16 |
| Figure 1-29 - 1-33 Well Perforations and Monthly Ground Water Levels Well #5 - #9, East Side Subarea | 1-16 |
| Figure 1-34 - 1-37 Well Perforations and Monthly Ground Water Levels Well #9 - #13, Forebay Subarea | 1-16 |
| Figure 1-38 - 1-43 Well Perforations and Monthly Ground Water Levels Well #14 - #19, Upper Valley Subarea | 1-16 |
| Figure 1-44 Annual Seawater Intrusion Rate into the Pressure Subarea (Simulated Flow Across the Coastline) | 1-19 |
| Figure 1-45 Cumulative Total Volume of Seawater Intrusion into the Pressure Subarea (Simulated Flow Across the Coastline) | 1-19 |

Table of Contents

Figure 1-46a 500 ppm Chloride Contour, 180-Foot Aquifer, Historical and Without Reservoir Simulation. September 1994..... 1-19

Figure 1-46b 500 ppm Chloride Contour, 400-Foot Aquifer, Historical and Without Reservoir Simulation. September 1994..... 1-19

Figure 1-47 Location of Upper Valley Wells Used for Water Quality Analysis 1-20

Figure 1-48a Upper Valley Subarea Ground Water Quality Monitoring Data Monitoring Wells with Higher Quality Water 1-20

Figure 1-48b Upper Valley Subarea Ground Water Quality Monitoring Data Monitoring Wells with Higher Quality Water 1-20

Figure 1-48c Upper Valley Subarea Ground Water Quality Monitoring Data Monitoring Wells with Higher Quality Water 1-20

Figure 1-49a Upper Valley Subarea Ground Water Quality Monitoring Well Data Monitoring Wells with Lower Quality Water 1-20

Figure 1-49b Upper Valley Subarea Ground Water Quality Monitoring Well Data Monitoring Wells with Lower Quality Water 1-20

Figure 1-50 Average Increase in Ground Water Levels, With vs. Without Reservoirs, Baseline Conditions (1958-1994) 1-22

Figure 1-51 Cumulative Volume of Stream Recharge in the Salinas Valley 1-23

Figure 1-52 Annual Seawater Intrusion Rate into the Pressure Subarea (Simulated Flow Across the Coastline)..... 1-23

Figure 1-53 Cumulative Total Volume of Seawater Intrusion into the Pressure Subarea (Simulated Flow Across the Coastline) 1-23

Figure 2-1 Annual Peak Discharges at Selected Long-Term U.S. Geological Survey Gaging Stations 2-4

Figure 2-2 Exceedence Probability, Salinas River Near Spreckels 2-6

Figure 2-3 Exceedence Probability, Salinas River Near Bradley 2-6

Figure 2-4 Annual Peak Discharges at Selected Long-Term U.S. Geological Survey Gaging Stations 2-6

Figure 2-5 Flood Study Unit Boundaries 2-14

Figure 2-6 Water Surface Elevations at River Mile 61.4 2-15

Figure 3-1 Important Factors to Consider in Flood Control Economic Evaluation 3-10

Figure 3-2 Cumulative Distribution of Costs Per Acre for EC2 Practices under the Emergency Conservation Program, 1995, Monterey County 3-16

LIST OF ACRONYMS

| | |
|------------------------------|----------------------------------------------------------------|
| BMP | Basin Management Plan |
| CDFA | California Department of Food and Agriculture |
| cfs | cubic feet per second |
| COE (or Corps) | U.S. Army Corps of Engineers |
| CUAW | Consumptive Use of Applied Water. |
| EBA | Economic Benefits Analysis |
| EC | Electrical Conductivity |
| ECP | Emergency Conservation Program |
| ESU | Economic Study Unit |
| FEMA | Federal Emergency Management Agency |
| FSA | Farm Service Agency |
| FSU | Flood Study Unit |
| GEMS | Ground Water Extraction Management System |
| GIS | Geographic Information System |
| GPS | Global Positioning System |
| HBA | Historical Benefits Analysis |
| HEC-1 | Hydrologic Engineering Center - Hydrologic Computer Program |
| HEC-2 | Hydrologic Engineering Center - Flood Routing Program |
| M & I | Municipal and Industrial |
| MCAC | Monterey County Agency Commissioner |
| MCWRA | Monterey County Water Resources Agency |
| NAVD | North American Vertical Datum |
| NGVD | National Geodetic Vertical Datum |
| O & M | Operations and Maintenance |
| ppm | parts per million |
| SVIGSM | Salinas Valley Integrated Ground Water and Surface Water Model |
| SVWP | Salinas Valley Water Project |
| TAF | thousands of acre feet |
| TDS | total dissolved solids |
| USBR (or Reclamation) | United States Bureau of Reclamation |
| USDA | U.S Department of Agriculture |
| USGS | United States Geological Survey |
| UCCES | University of California Cooperative Extension Service |
| WRAGIS | Water Resources Agency Geographic Information System |

Executive Summary



MONTGOMERY WATSON

AR 07025

B a c k g r o u n d

The California Department of Water Resources (DWR) prepared a comprehensive plan in 1946 entitled Bulletin 52, Salinas Basin Investigation. Bulletin 52 was a comprehensive planning document developed to provide a basis for solving the seawater intrusion and ground water overdraft conditions that had been identified in the Salinas Valley. In Bulletin 52, the DWR (then the Department of Public Works) suggested a solution to solve the seawater intrusion and overdraft conditions that included surface water storage, conveyance, and diversion facilities.

Based on the recommendation contained in Bulletin 52, the Monterey County Water Resources Agency (MCWRA) constructed Nacimiento and San Antonio Reservoirs. These two reservoirs were constructed as the first facilities envisioned in Bulletin 52, as the Bulletin recognized that conveyance was an integral part of the solution to seawater intrusion and overdraft conditions. As stated in Bulletin 52, "...released surface storage and increased percolation in the stream beds south of Gonzales, without artificial means of conveyance, would be ineffective to relieve overdraft conditions in the East Side and Pressure Areas."

Although partially effective, the construction and operation of these two reservoirs has not solved the overdraft and seawater intrusion conditions in the Salinas Valley. Based on the most recent analysis, the average rate of seawater intrusion during the period of October 1949 to September 1994 is estimated to be 11,000 acre-feet per year. This seawater intrusion has occurred in both the

180-foot and the 400-foot aquifers. By 1996, the seawater intrusion front, as defined by the 500 ppm chloride concentration contour, had advanced approximately 4.5 miles inland in the 180-foot aquifer, underlying approximately 11,000 acres of irrigable land. This intrusion of seawater has forced a large number of water supply wells to be redrilled into the 400-foot aquifer.

Additionally, a large portion of the 400-foot aquifer in the Castroville and Marina Coast areas also suffers from seawater intrusion. This has caused approximately 4,300 acres of irrigated farmland to be underlain by seawater in the 400-foot aquifer. In these areas where both the 180 and 400 foot aquifers are intruded by seawater, the Deep Aquifer has become the major source of water supply for irrigation, and municipal and industrial (M&I) water.



The Nacimiento and San Antonio Reservoirs began operations in 1957 and 1967, respectively, to serve as multiple use reservoirs providing flood control, water conservation, and recreation benefits. The reservoirs were built and are operated and maintained using funds from property owners in zones 2 and 2A in the Salinas Valley. MCWRA continues to operate the Reservoirs consistent with well-established and proven criteria used to operate other reservoirs throughout the country with similar purposes.

P u r p o s e

Operation of the reservoirs over the last 40 years has reduced the rate of seawater intrusion and ground water overdraft. However, the construction and operation of the reservoirs to increase recharge to the ground water basin also has brought other benefits to the Salinas Valley. The purpose of this Historic Benefits Analysis (HBA) was to identify and quantify these benefits. The study area where these historic benefits were evaluated is shown in Figure ES-1.

The major categories of benefits associated with the operations of Nacimiento and San Antonio Reservoirs are:

1. *Hydrologic benefits*, including higher ground water levels, greater reliability of ground water supplies, better operation of wells, and higher quality of ground water;

2. *Flood control benefits*, including lower risk of flooding during above-normal and extreme rainfall events, and lower risk of agricultural soil erosion; and
3. *Economic benefits* associated with the hydrologic and flood control benefits.

In conducting this study, the most extensive and reliable data sets available from the public and MCWRA, as well as other federal, state and local agencies are used. Additionally, the project team has used the best and most reliable analytical models available to analyze the hydrology and economy in the Salinas Valley.

The major assumption used throughout the HBA is that the benefits from operations of the reservoirs are measured as the difference between the conditions in the valley "with" and "without" the reservoirs in place, under the same level of development. This approach is a common practice in planning studies and is consistent with the planning guidelines set forth by the U.S. Water Resources Council in 1983.

The remaining portion of this Executive Summary describes, in brief, the approach, assumptions, and results of the Historic Benefits Analysis. Detailed information on each subject and impact area is found in the appropriate sections of the HBA report, and its appendices.

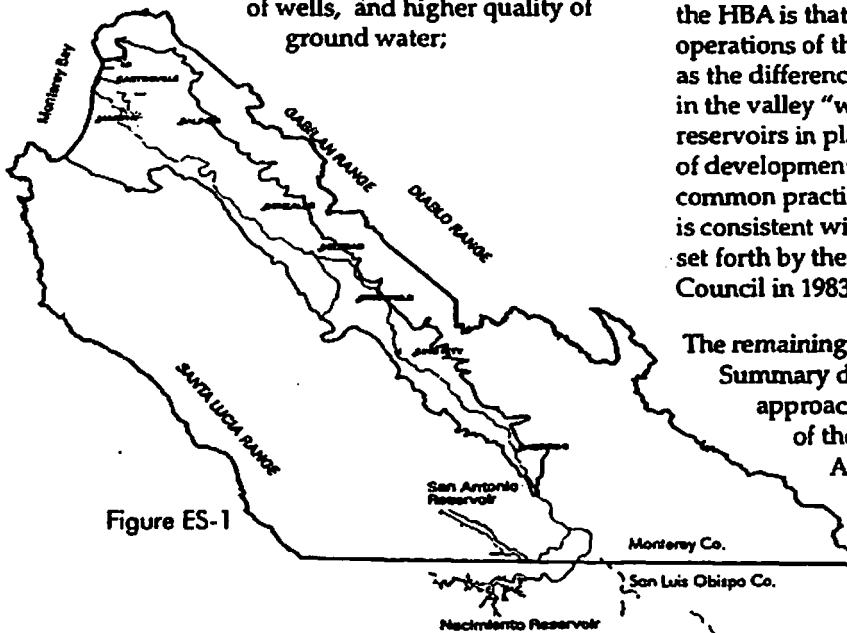

Figure ES-1

Hydrologic Benefits Analysis

The hydrologic benefits associated with the operation of Nacimiento and San Antonio Reservoirs were analyzed in four major impact areas:

- Ground water levels,
- Well construction and rehabilitation,
- Seawater intrusion, and
- Regional ground water quality.

The Salinas Valley Integrated Ground and Surface water Model (SVIGSM) was used to estimate and quantify the hydrologic benefits. The SVIGSM is a comprehensive hydrologic model that simulates the various components of the water cycle, including the agricultural and urban land and water uses, evapotranspiration and deep percolation through the soil and unsaturated zones, flows in the river systems, subsurface flows in the ground water basin, and the dynamic interaction of these components over time.

The SVIGSM was developed for MCWRA in 1993 and revised in 1995. Subsequently, the SVIGSM was updated with additional data and recalibrated for the 1970-1994 hydrologic period. The HBA required the analysis of benefits, starting prior to the time the reservoirs began operating. As a result, the hydrologic, land use and water use data were extended from the original 1970-1994 period, back in time to 1949. The extension of the SVIGSM database was completed and the model was verified for accuracy of calibration. Minor modifications were made

to the model to verify the simulation results with the longer periods of record. In addition, recently obtained aquifer parameter data for the Arroyo Seco Cone area was incorporated into the model, and appropriate calibration of the model was performed.

The results of the hydrologic analysis in the four impact areas are described below.

Ground Water Levels

A total of 30 thousand acre-feet per year (TAF/yr) of fresh ground water has been added to the ground water storage through recharge from the Salinas River as a result of operation of the reservoirs during water years 1958 through 1994.

This additional recharge has resulted in generally higher ground water levels throughout most of the Valley.

Consequently, the average rate of seawater intrusion has been reduced by 7 TAF per year

Figure ES-2 shows the distribution of average annual changes in

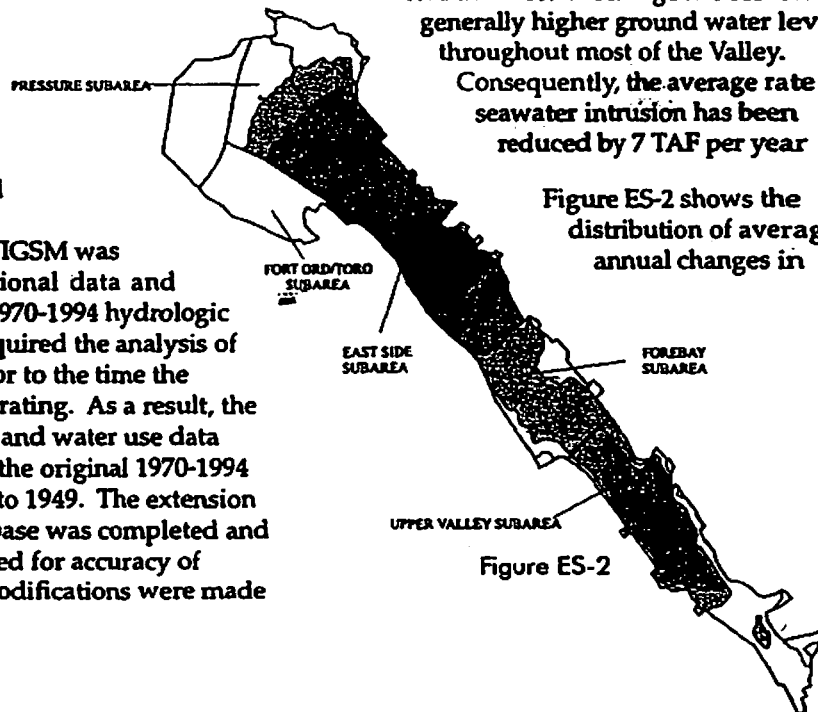

Figure ES-2

ground water levels for the period 1958-1994, with the change representing the increase in ground water level that has resulted from the operation of the reservoirs, as compared to the estimated ground water levels that would have existed, had the reservoirs not been constructed.

The Salinas Valley was divided into 12 Economic Study Units (ESUs) to separate the geographic areas in the Valley that have received similar average benefits from higher ground water levels due to the operation of reservoirs. Figure ES-3 shows the delineation of the ESU boundaries.

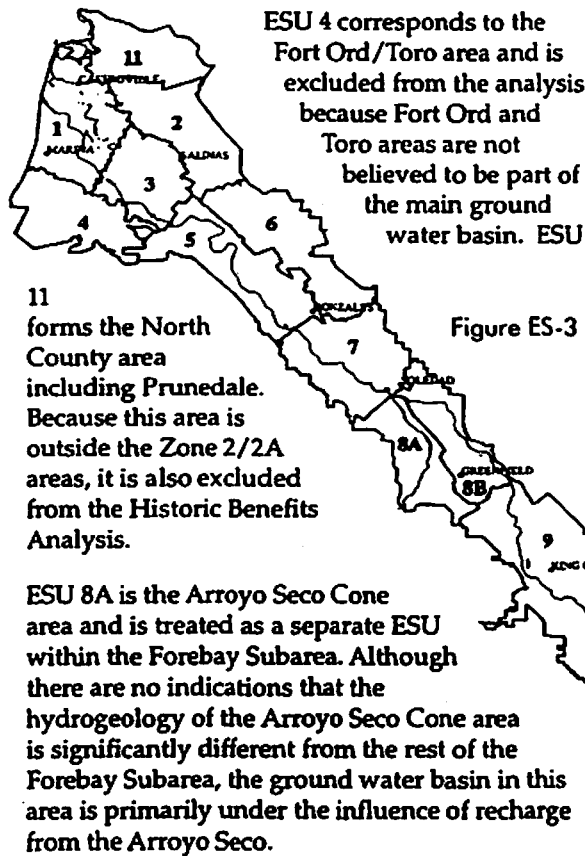

Figure ES-3

Well Construction and Rehabilitation

Changes in ground water levels affect energy costs resulting from differences in pumping lift. In addition, the performance of water supply wells are affected, when the ground water levels drop below the top of the screened interval or pump intake. The following impact criteria were used in the comparison of ground water well performance under "with" and "without" reservoir conditions:

- **Hydrologic Impacts**, when the ground water levels fall within the screened interval of the well; and
- **Well Performance Impacts**, when the changes in ground water levels affect well operations. This impact could be relatively minor (e.g., affecting the pump intake structure [bowl]), or may be relatively major (e.g., dewatering a large portion of the screen, causing loss or production or inefficiencies in well operation that require replacing the well structure).

384 wells were selected as samples for the analysis to evaluate impacts on the water supply wells in the Salinas Valley. Care was taken that the selected wells were distributed among the subareas: 185 wells were in the Pressure Subarea, 84 were in the East Side Subarea, 65 were in the Forebay Subarea, and 50 wells were in the Upper Valley Subarea.

The well performance analysis shows that, on average, only 2 percent of the wells in the valley would have been impacted under the "without reservoir" scenario based on the two criteria described above. On an individual subarea basis, 1.6 percent of the wells in the Pressure Subarea and 1.2 percent in

Table ES-1 presents the average, minimum, and maximum differences in ground water elevations during 1958-94 in each ESU, between the historical and "without reservoir" conditions.

Table ES-1
Impact of Historical Operations of Reservoirs
on Ground Water Levels
(Average Annual for 1958-94)

Increase in Regional Average Annual Ground Water Levels
With and Without Reservoirs (feet)

| ESU | Minimum | Maximum | Average Increase |
|-----|----------|----------|---------------------|
| | Increase | Increase | |
| 1 | 1.1 | 7.0 | 4.5 |
| 2 | 1.6 | 19.0 | 14.2 |
| 3 | 5.5 | 28.6 | 16.9 |
| 4 | N/A | N/A | N/A |
| 5 | 8.7 | 47.8 | 26.9 |
| 6 | 2.3 | 34.9 | 23.3 |
| 7 | 2.1 | 35.1 | 16.0 |
| 8A | 0.6 | 11.9 | 5.9 |
| 8B | 1.4 | 13.2 | 6.4 |
| 9 | 4.2 | 26.7 | 9.7 |
| 10 | 0.6 | 4.6 | 2.3 |
| 11 | N/A | N/A | N/A |

the East Side Subarea would have required minor modifications to continue operations under the "without reservoir" scenario. Most of the wells in the Pressure and East Side Subareas are relatively deep and have large screen intervals. No wells in the Forebay Subarea would have been affected. In the Upper Valley Subarea, the wells are generally shallower and have relatively shorter screen intervals. Therefore, approximately 8 percent of the wells in this area would have required replacement or supplemental wells to have been constructed under the "without reservoir" scenario. These wells would have been impacted because lower ground water levels would have been experienced if the reservoirs had not been constructed during drought conditions. The economic analysis of these impacts is summarized in the Water Supply Benefits section of this summary under "Economic Benefits".



Seawater Intrusion

One of the main objectives of existing reservoir operations is to reduce and possibly stop seawater intrusion. The SVIGSM was used to analyze the impacts of the "without reservoir" condition on the rate and extent of seawater intrusion.

Seawater intrusion into the aquifers of the Pressure Subarea is controlled by the gradient between the ground water level in the Pressure Subarea and the sea level. The simulated average rate of seawater intrusion for the period 1958 to 1994 is estimated to be approximately 11 TAF/yr. Annual and seasonal changes in hydrologic conditions cause this rate to fluctuate. During dry periods, the rate increases; during wet periods, seawater intrusion decreases and, in very wet periods, the gradient occasionally may reverse towards the Bay. Based on the results of the Historic Benefits Analysis, if the reservoirs did not exist, the average rate of seawater intrusion would have been 7 TAF/yr higher. This would have resulted in an additional 230 TAF of seawater intruding into the ground water aquifer of the Salinas Valley during the periods of 1958-1994. Figure ES-4 shows the increase in average annual and cumulative seawater intrusion occurring during this period, had the reservoirs not been constructed.



Historically, ground water affected by seawater intrusion has been identified as that portion containing chloride concentrations of 500 parts per million or more. The extent of the seawater intrusion front in the coastal aquifers was approximately 4.5 miles inland in 1994, underlying approximately 11,700 acres of irrigated farmland in the 180-foot aquifer and 4,300 acres in the 400-foot aquifer. Based on the HBA analysis, if the reservoirs were not in place, the seawater intrusion front would have been 6.5 miles inland in 1994, underlying approximately 4,900 additional acres of irrigated farmland in the 180-foot aquifer, and 1,200 additional acres in the 400-acre aquifer.

The increased rate and extent of seawater intrusion would have caused approximately 41 additional wells to be replaced with deeper ones into either the 400-foot Aquifer or the Deep Aquifer.

Regional Ground Water Quality

The potential impacts of the reservoirs on ground water quality parameters not related to seawater intrusion, such as Total Dissolved Solids (TDS), were examined because of concerns raised during the HBA workshop process. Although there was no model simulation of the effects of the operation of reservoirs on the movement of poor quality water in other parts of the Valley, an evaluation of water quality data along with an analysis of changes in ground water flow rates revealed the following:

- Areas within the Upper Valley Subarea east of the Salinas River are affected by water quality problems that stem from natural recharge of very poor quality water coming from the eastern foothills

Figure ES-4

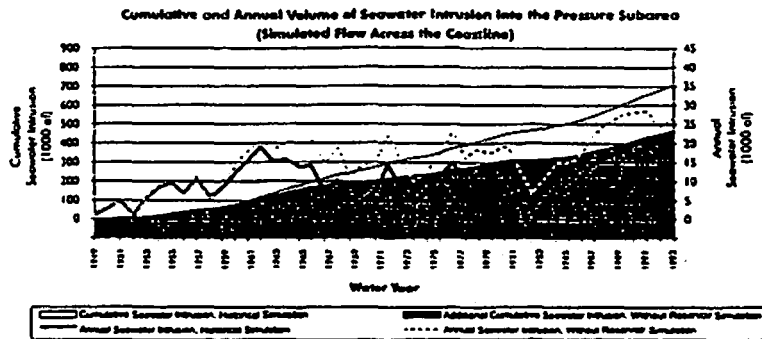

bordering the Salinas Valley. The water is generally highly alkaline with high levels of TDS ranging from 2,000 to 4,000 milligrams per liter (mg/l).

- In general, the fresh water released from the reservoirs during the irrigation season recharges the aquifer along the Salinas River. This fresh water recharge serves to improve the quality of ground water closer to the river.
- Preliminary analysis of the data shows that the wells in the proximity of the river generally have much lower TDS concentrations. On the other hand, those farther away from the river not only have higher TDS values, but also exhibit potentially poorer water quality during drought conditions.
- Although ground water flow rates increase on the order of 10-15 percent during average and below normal hydrologic conditions, the water quality data is not collected frequently enough to quantify the changes in water quality in the vicinity of production wells.

Flood Control Benefits Analysis

Some of the major benefits of the Nacimiento and San Antonio Reservoirs have been to provide improvements in flood control. The reservoirs have significantly reduced the magnitude and frequency of flooding in the Valley. To analyze and quantify the flood control benefits, a hydraulic model of the Salinas River was constructed to simulate the propagation of the 100-year flood through the river channel. (A 100-year flood corresponds to a streamflow rate that has a probability of being equaled or exceeded one percent of the time.

Figure ES-5 shows the relative scale of the high flows in the Salinas River at Bradley and at Spreckels compared to what is estimated as the 100-year flow at each site. Note that the 1969 and 1995 floods were somewhat greater than a 100-year flood at Bradley and the 1995 flood was greater than the 100-year flood at Spreckels.

Based on the flood control benefits analysis with the reservoirs in place, the flow rate for a 100-year flood at Bradley is approximately 87,000 cubic feet per second (cfs), and that at Spreckels is approximately 86,000 cfs. If the reservoirs were not in place, the 100-year flood (as measured for the "with reservoir" conditions) would have recurred, on the average, every 8 years at Bradley and every 22 years at Spreckels.

While the flow rates for a 100-year flood with the reservoirs

in place are estimated to be 87,000 cfs and 86,000 cfs at Bradley and Spreckels, respectively, the flow rates without the reservoirs in place are estimated to be 167,000 cfs and 149,000 cfs, respectively. This increased flow rate would have caused significantly more damage to the agricultural production and infrastructure, and industrial and municipal facilities and buildings in the Salinas Valley.

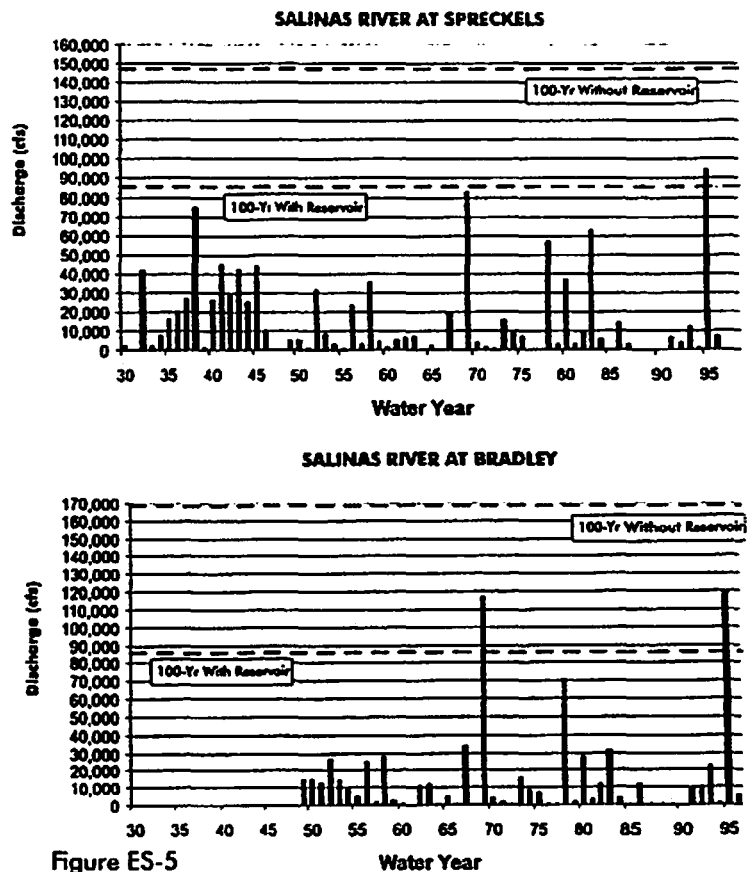

Figure ES-5

It is recognized that the private levees along the river have provided protection during some flood events, such as that in 1995. However, the majority of the private levee systems are not certified by the Federal Emergency Management Agency (FEMA). In addition, the flood protection provided by the levees can be attributed to the levees themselves, not to the operation of the reservoirs. The benefits provided by the privately constructed levees is, thus, attributable to the individual interest that constructed these, and are not the result of reservoir operations. Therefore, the private levees are not considered in this analysis.

The hydraulics of a 25-year flood flow also were analyzed to estimate the effects of a medium-level flood in the Valley. A 25-year flood flow rate (with reservoirs in place) is estimated to be 57,000 cfs at Bradley, and 53,000 cfs at Spreckels. Without the reservoirs, a flood of this size would occur every 5 years at Bradley, and every 8 years at Spreckels.

In order to analyze the distribution of economic benefits associated with flood control operations of the reservoirs, Flood Study Units (FSU) are defined. The boundaries of FSUs are approximately delineated based on the inundation areas in each FSU, along Salinas River. Figure ES-6 shows the boundaries of FSUs.



Figure ES-6

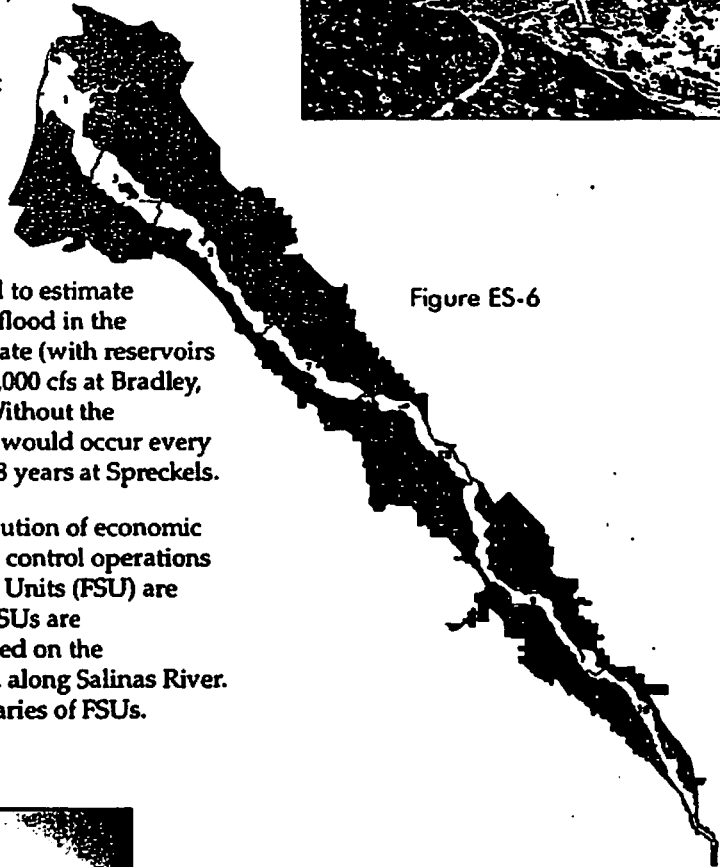

Economics Benefits Analysis

The economic benefits, described in this report can be divided into two categories—water supply benefits and flood control benefits. The water supply benefits are summarized in Table ES-2, and can be further segregated into three subcategories:

1. Avoided costs for ground water pumping,
2. Avoided costs from drilling new wells or modifying the existing wells (such as lowering the bowls), and
3. Avoided well costs associated with seawater intrusion.

The water supply benefits are reported by the ESUs shown in Figure ES-3, based on areas with similar ground water impacts. However, flood control benefits are reported by the FSUs as shown in Figure ES-6.

Water Supply Benefits

Avoided Costs for Ground Water Pumping

The first category of water supply benefits includes avoided energy, and operational

maintenance costs for increased pumping lift. Data from the hydrologic analysis were used to estimate an annual avoided ground water pumping cost that has been realized by ESU, with the reservoirs in place, as compared to the conditions, if the reservoirs had not been constructed. The hydrologic analysis estimated the change in average ground water levels under "with" and "without reservoir" conditions using SVIGSM. Increases in ground water levels were then

multiplied by the average pumping cost of 22.5 cents per acre-foot per foot of lift to determine the avoided pumping costs.

Table ES-2
Summary of Water Supply Economic Benefits By ESU

| Economic Study Units (ESU) | Water Supply Benefits | | |
|----------------------------|------------------------------|-------------------------------|-------------------------------|
| | Groundwater Level Changes | | Seawater Intrusion in 1994 |
| | Annual Avoided Pumping Costs | Annualized Avoided Well Costs | Annualized Avoided Well Costs |
| ESU1 | \$43,000 | \$1,000 | \$241,000 |
| ESU2 | \$164,000 | \$1,000 | \$0 |
| ESU3 | \$149,000 | \$1,000 | \$0 |
| ESU4 | N/A | N/A | N/A |
| ESU5 | \$293,000 | \$1,000 | \$0 |
| ESU6 | \$179,000 | \$1,000 | \$0 |
| ESU7 | \$234,000 | \$0 | \$0 |
| ESU8A | \$63,000 | \$0 | \$0 |
| ESU8B | \$69,000 | \$0 | \$0 |
| ESU9 | \$264,000 | \$68,000 | \$0 |
| ESU10 | \$16,000 | \$16,000 | \$0 |
| ESU11 | N/A | N/A | N/A |
| TOTAL | \$1,474,000 | \$89,000 | \$241,000 |

Flood control benefits are summarized in Table ES-3, and can be divided into two subcategories:

1. Prevention of agricultural damages, including reduction in damages from erosion, and
2. Prevention of damages to buildings and structures.

Avoided Cost of Drilling New Wells or Modifying Existing Wells

The second category of water supply benefits is related to impact of changes in ground water levels on the yield and performance of the water wells. In some areas the decline in ground water levels, for the "without reservoir" conditions, would have necessitated additional capital outlay. Wells would had to have been modified or replaced if water levels dropped far enough under the "without reservoirs" condition, especially during drought conditions. Sample wells in each hydrologic subarea were analyzed to determine the type of action required: no action, well modification, or drilling of supplemental or replacements wells. The results of this analysis were used to project the action needed for each ESU within each subarea. Avoided costs were estimated by multiplying the replacement costs, adjusted for depreciation of existing wells, and modification costs by the total number of wells requiring each action.

Avoided Well Cost of Seawater Intrusion

The third category of water supply benefits includes the avoided costs of wells that would have been replaced in the absence of the reservoirs because of seawater intrusion. Seawater intrusion areas were estimated for conditions "with" and "without" reservoirs, based on hydrologic analyses. Since an actual count of irrigation wells affected by seawater intrusion was not available, the number was estimated using information on the affected irrigated acreage, applied water for the affected acreage, and average well production. The avoided well costs then, were calculated on the basis of the number of these wells that would have needed to be drilled to a deeper aquifer under the "without reservoir" conditions. It was noted

that some of the wells in the area affected by seawater intrusion would not have needed to be re-drilled because they are already at a sufficient depth.

Flood Control Benefits

Prevention of Agricultural Damages

The first category of flood control benefits of the operation of reservoirs is related to damages to agricultural industry. The estimates of flood control benefits for agriculture that have been realized due to the reservoirs being in place are based on: 1) increases in net farm income, and 2) reductions in the costs for the repair of flood damages. The increases in net farm income were measured using crop budgets to represent conditions "with" and "without" reservoirs. Repair costs include grading, leveling, sediment and debris removal, and replacement or repair of damaged irrigation equipment, wells, and other farm equipment. The benefits from avoided repair costs occur both on: 1) lands not flooded or flooded less frequently as a result of the reservoirs, and 2) lands flooded but with a reduced water velocity and duration of flooding.

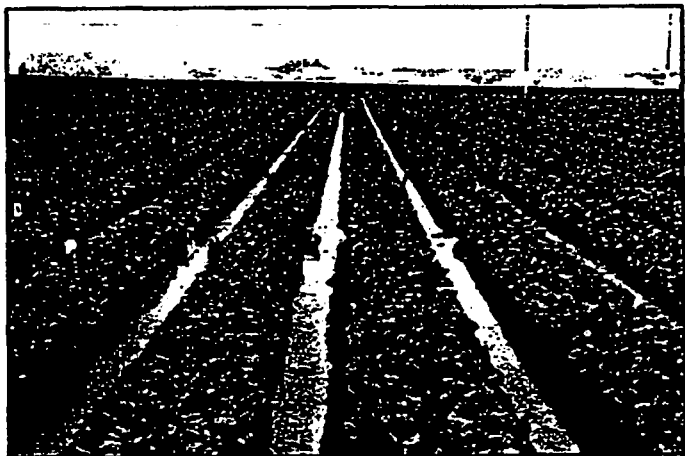

Prevention of Damages to Buildings and Structures

The second category of flood control benefits is the prevention of damages to buildings and structures. Flood control benefits to buildings and structures are estimated by subtracting the expected annual damages and losses with the reservoirs from those expected without the reservoirs.

The number, location, and size of buildings and structures lying within the 100-year floodplain "without reservoirs" were estimated using U.S. Geological Survey quadrangle maps of the valley and visual inspection. The "without reservoirs" 100-year floodplain represents the area presently being protected by the reservoirs. A total of 1,118 buildings and structures are presently located in the 100-year, "without reservoirs" flood plain.

Expected annual damages and losses without the reservoirs are estimated at \$5.7 million. About 80

percent of this amount represents physical damages. Contents damage has been estimated to be double the estimated structural damage. Relocation costs comprise about 20 percent of the total damages and losses. Income and public service losses are less than 1 percent of the total damages and losses.

With the reservoirs in place, the estimated level of annual damages and losses are reduced to \$1.2 million. Thus, the annual flood control benefit from the prevention of damages to buildings and structures is \$4.5 million. The distribution of these benefits among the FSUs is shown in Table ES-3.

Table ES-3
Summary of Flood Control Economic Benefits By FSU

| Economic Study Units (ESU) | Flood Control Benefits | |
|----------------------------|--------------------------------------------------|--------------------------|
| | Agricultural Impacts | Buildings and Structures |
| | Annual Income Increases and Repair Costs Avoided | Annual Avoided Costs |
| FSU1 | \$771,000 | \$3,126,000 |
| FSU2 | \$43,000 | \$0 |
| FSU3 | \$627,000 | \$1,226,000 |
| FSU4 | N/A | N/A |
| FSU5 | \$1,270,000 | \$106,000 |
| FSU6 | N/A | N/A |
| FSU7 | \$735,000 | \$3,000 |
| FSU8A | \$39,000 | \$0 |
| FSU8B | \$502,000 | \$1,000 |
| FSU9 | \$1,222,000 | \$5,000 |
| FSU10 | \$300,000 | \$9,000 |
| FSU11 | N/A | N/A |
| TOTAL | \$5,510,000 | \$4,476,000 |

Summary and Conclusions

The Nacimiento and San Antonio reservoirs were constructed in mid-1950s and mid-1960s to regulate the flows of the Salinas River, augment the ground water recharge through the Salinas River bed, reduce the rate of seawater intrusion, and provide flood protection to the downstream agricultural and urban areas. The results of this Historic Benefits Analysis demonstrate that these benefits have been provided through the construction and operation of the reservoirs.

The Historic Benefits Analysis was performed to determine the contributions that the historic operation of reservoirs have brought to the Salinas Valley agricultural and urban communities, and the geographic distribution of these contributions. Although the benefits vary significantly throughout the Salinas Valley, nearly all areas within Zones 2 and 2A are receiving some level of benefit.

Following is the summary of the benefits of historic operation of the two reservoirs.

Hydrologic Benefits

The hydrologic benefits, as discussed in Section 1 of this report, are summarized as follows:

Ground Water Levels

The operation of reservoirs during the period 1958 to 1994 has generally raised the ground water levels in most areas of the Valley. The average annual increase in ground water levels due to the operation of the reservoirs is between 2 to 27 feet. During above normal rainfall conditions the increase in ground water levels is estimated as 1 to 9 feet, while it is as much as 5 to 48 feet during drought conditions.

Seawater Intrusion

The operation of reservoirs has substantially reduced the rate and extent of seawater intrusion. The average annual rate of seawater intrusion has been reduced by 7 TAF/Yr, or approximately 230 TAF less seawater intrusion into the Salinas River Basin, over the 1958-1994 period. The HBA also shows that, had the reservoirs not been constructed, approximately additional 4,900 and 1,200 acres of irrigated farmland would have been underlain by seawater intrusion in the 180- and 400-foot aquifers, respectively.



Well Construction and/or Rehabilitation

The operation of the reservoirs has resulted in improved ground water conditions. Under the scenario without the reservoirs constructed, approximately 5 percent of the wells in the Salinas Valley would have been impacted based on the two criteria of hydrologic and well performance impacts. Based on this analysis, 1.6 percent of the wells in the Pressure Subarea and 1.2 percent in the East Side Subarea would have required minor modifications to continue operations under the "without reservoir" scenario. The majority of the wells in the Pressure and East Side Subareas are relatively deep and have large screen intervals. No wells in the Forebay Subarea would have been affected if the reservoirs were not constructed. In the Upper Valley Subarea, the wells are

generally shallower and have relatively shorter screen intervals. Therefore, approximately 8 percent of the wells in this area would have required replacement or supplemental wells under the "without reservoir" scenario, primarily because of impacts during drought conditions.

Ground Water Quality

A review of the available information indicates that there are some benefits to regional ground water quality that have resulted from construction and operation of the two reservoirs. However, the data is not adequate to allow for an estimation of the level of regional ground water quality benefits that have actually accrued from operation of the two reservoirs. Therefore, no economic benefits have been estimated for enhancements to regional ground water quality.

Flood Control Benefits

Flood control benefits have resulted from construction and operation of the two reservoirs. The area receiving the greatest benefits are located along the river and in the northern portions of the Valley, particularly in FSU 1. Benefits occur in terms of reduced levels of flooding and reduced frequencies of flooding. Benefits are received by agricultural interests in protection to crops and in reduced levels of repairs required following flood events. Benefits are also received by non-agricultural interests in terms of reduced damages to buildings and their contents.

Economic Benefits

Tables ES-2 and E-3 provide a summary of the benefits realized in each category by ESU or FSU.

In water supply category, ESU 5 and 9 have received the greatest benefits, while ESUs 1, 8A, 8B, and 10 have received the least. ESU 1 is the only area that has benefited from reduction in seawater intrusion.

Although the reservoirs have provided significant benefits in terms of improved water supply, from an economic standpoint, flood control is the predominant benefit that has resulted from construction and operation of the two reservoirs. In the flood control category, FSU 1 has received the greatest benefit. While FSUs 3, 5 and 9 have received moderate benefits, FSUs 2 and 8A have received the least benefit.

Other Benefits

While the HBA study has quantified certain categories of benefits that the reservoirs have brought to the economy of the Valley, there are other intangible benefits that have not been directly analyzed in this study. Some of the benefits, such as recreation, are realized by the Valley agricultural and/or urban community on a relatively equal basis. Some other, such as environmental benefits, are not tangible and quantifiable. These miscellaneous benefits include:

- Ground water quality benefits outside the seawater intruded area,
- Value of good quality water in storage,
- Value of ground water basin for storage and distribution,
- Value of reservoirs as insurance against rainfall variations,
- Recreational and environmental benefits.



Section 1



MONTGOMERY WATSON

AR 07039

Section 1

Hydrologic Benefits Analysis

BACKGROUND

In light of the dependence of Salinas Valley water users upon the ground water supply, and the need to carefully manage the ground water basin as a reliable source of quality water, the Monterey County Water Resources Agency (MCWRA) began efforts to develop the Salinas River Basin Management Plan (BMP). The primary goals of the BMP are to stop seawater intrusion, balance the ground water basin, and ensure adequate supplies of quality water to meet current and future (2030) water demands.

The MCWRA is now beginning to investigate the implementation costs of the BMP. Since allocation of the costs will become an issue as the development of the BMP progresses, The MCWRA is seeking an understanding of the historical benefits of past projects. The goal of the Historic Benefits Analysis (HBA) is to analyze and quantify the historical benefits, as well as the distribution of the benefits, resulting from the construction and operation of Nacimiento and San Antonio Reservoirs. Ultimately, the water supply and flood control benefits will be determined on an economic basis for the period of operation of the two reservoirs. This section describes the process and results of the analysis of the hydrologic benefits of the operation of the reservoirs. The economic impacts of these benefits are described in Section 3.

HYDROLOGIC SETTING

The Salinas Valley extends approximately 120 miles northwest

from the mountain regions in San Luis Obispo County near Santa Margarita to Monterey Bay in Monterey County. The Valley is drained by the Salinas River. The focus of this study is the portion of the valley within Monterey County, spanning from just north of Bradley to the Monterey Bay. Along its length, this section of the valley is approximately 80 miles, and is approximately 3 miles wide near Bradley, and 10 miles wide at the Monterey Bay coast. The Valley is bounded on the east by the Gabilan and Diablo Ranges, and on the west by the Sierra de Salinas and Santa Lucia Range.

The primary land use within the Salinas Valley is agricultural. Since the late 1940s, irrigated acreage within the Valley has increased significantly, with steady increases in the 1940s and 1950s, and more rapid increases in the 1960s and 1970s. Total irrigated acreage has remained relatively constant since the 1980s. Urban acreages have also experienced substantial growth, most of which has occurred in the major urban areas, including Castroville, Gonzales, Greenfield, King City, Marina, Salinas, and Soledad. As the agricultural and urban areas have expanded, so have the water needs of the Valley.

Although a small amount of surface water is used from the Arroyo Seco, the source for almost all of the water used in the Valley is ground water. The average annual ground water pumping in the Valley for the period from 1949 to 1994 is estimated to be approximately 518,000 acre-feet of which 489,000 acre-feet is pumped primarily for agricultural use and irrigation, and

Section 1 - Hydrologic Benefits Analysis

29,000 acre-feet is pumped for municipal and industrial use. These pumping estimates are based on estimates of reported historical irrigated acreages, crop varieties, estimates of irrigation practices, urban population, and per capita water use.

Recharge to the ground water basin occurs primarily from precipitation, irrigation applied water, and stream recharge from the Arroyo Seco and Salinas River. It is estimated that stream recharge accounts for approximately half of the total basin recharge. Average precipitation in the Valley ranges from 15 to 60 inches in the mountain ranges on either side of the Valley to 10 to 15 inches within the Valley itself. Most of the precipitation occurs in winter, from November to March. To help increase the utilization of Salinas River flows for ground water recharge and to provide flood control benefits, Nacimiento and San Antonio Reservoirs were constructed in 1957 and 1965, respectively. These reservoirs have been operated to optimize Salinas River recharge by storing winter runoff and making releases in a timely manner during the irrigation season, when recharge potential is highest.

The high dependence on ground water and the growth in water demands have put a strain on the ground water resources of the Salinas Valley. The balance of ground water pumping and recharge in an aquifer system will affect the ground water levels. Despite the efforts to maintain the balance in the Salinas Valley, some areas have experienced declines in ground water levels. Due to increased pumping during the irrigation season, seasonal drops in water levels, as well as declining annual trends in parts of the Valley, have been observed.

Declining ground water levels have the associated effect of lowering, or even reversing, the hydraulic gradient in the coastal areas. This lower hydraulic gradient, particularly during irrigation season and during dry years, results in the intrusion of seawater into the coastal aquifers along Monterey Bay. Monitoring has shown that the intrusion is more prevalent in the shallow aquifers and to a lesser extent in the deeper zones. This seawater intrusion significantly degrades the ground water quality, and forces the water users in these areas to abandon shallower wells and drill to deeper aquifers to ensure good quality water. Over time, the front of seawater intrusion has moved steadily inland. Stopping the movement of seawater has been a primary objective of the BMP.

HISTORICAL RESERVOIR OPERATIONS

Nacimiento and San Antonio Reservoirs began operations in 1957 and 1967, respectively, for purposes of flood control, water conservation, and recreation. The reservoirs were built and are operated and maintained using funds from property owners in the Salinas Valley. The MCWRA operates Nacimiento and San Antonio Reservoirs consistent with well-established and proven criteria used to operate other reservoirs throughout the country with similar purposes.

During winter, when heavy rains can cause flooding in the Salinas Valley, the reservoirs provide flood protection by controlling the Nacimiento and San Antonio Rivers, two of the largest tributaries of the Salinas River. The capacity to temporarily store flood water is maintained in both reservoirs.

Section 1 - Hydrologic Benefits Analysis

Once a flood peak on the Salinas River passes the Nacimiento and San Antonio Rivers, MCWRA releases water to regain the empty flood spaces in the lakes. As spring approaches and the chance of a large flood diminishes, the amount of flood storage needed decreases and the lakes are allowed to fill. The maximum flood control storage in Nacimiento Reservoir is 110 thousand acre-feet (TAF) and that in San Antonio Reservoir is 90 TAF.

The conservation pool in a reservoir is the remaining storage space not required to be kept empty for flood control purposes. Nacimiento Reservoir has a conservation pool of 245 TAF and San Antonio Reservoir has a conservation pool of 222 TAF. Historical records show that the average annual flow into Nacimiento is about 200 TAF and about 70 TAF into Lake San Antonio. Releases are made from the reservoirs to maintain a 3 to 1 ratio (Nacimiento to San Antonio) of available storage in the water conservation pools at the end of the irrigation season. This operating rule minimizes the likelihood of spilling of water from Nacimiento Reservoir that could have been used for other purposes.

Recharge of the ground water basin in Salinas Valley is the primary purpose of Nacimiento and San Antonio Reservoirs. During late spring, summer, and fall, when the Salinas River would normally be dry, enough water is released from the reservoirs to keep the Salinas River flowing, without allowing water to flow to the ocean. The amount of water released from storage each year is determined by the quantity needed to replenish the ground water basin (more in a dry year, less in a wet year).

The reservoirs are operated to maintain minimum pools of 22 TAF in Nacimiento Reservoir and 23 TAF in San Antonio. The lakes are operated above these minimum levels to the extent possible, consistent with the priorities of other uses. In years when releases from both Nacimiento and San Antonio Reservoirs are made, consideration is given to releasing from both dams to balance the recreational impacts in an equitable manner.

SALINAS VALLEY HYDROGEOLOGY





The Salinas Valley ground water basin has been divided into four hydrologic subareas, the Pressure Subarea, East Side Subarea, Forebay Subarea, and Upper Valley Subarea, as shown in Figure 1-1. These subareas do not represent different ground water subbasins, but are used to designate different areas within the basin with different hydrogeologic characteristics. These characteristics, as well as the hydrogeologic boundaries that define each subarea, are discussed below.

- **Pressure Subarea:** The Pressure Subarea is in the northwest part of the Salinas Valley, bordering the Monterey Bay. Along the southwest side of the Pressure Subarea south of Salinas, the boundary of the ground water basin is the contact of the alluvium with the metamorphic rocks of the Sierra de Salinas. It is thought that the King City Fault, along the western boundary of the Pressure Subarea, acts as a barrier between the Salinas ground water basin and the Pressure Subarea, which is considered part of the Seaside basin (Durbin, 1978). Recent hydrologic investigations of the Fort Ord area has failed to confirm the existence of the King City Fault, so

Figure 1-1

**Salinas Valley Historical
Benefits Analysis
Subarea Map**

LEGEND

-  Monterey County Boundary
-  Subarea Boundaries
-  Cities
-  Rivers



**Monterey County
Water Resources Agency**

Source: MCWRA

Note: The scale and configuration of all information shown hereon are approximate and are not intended as a guide for design or survey work.

AR 07043

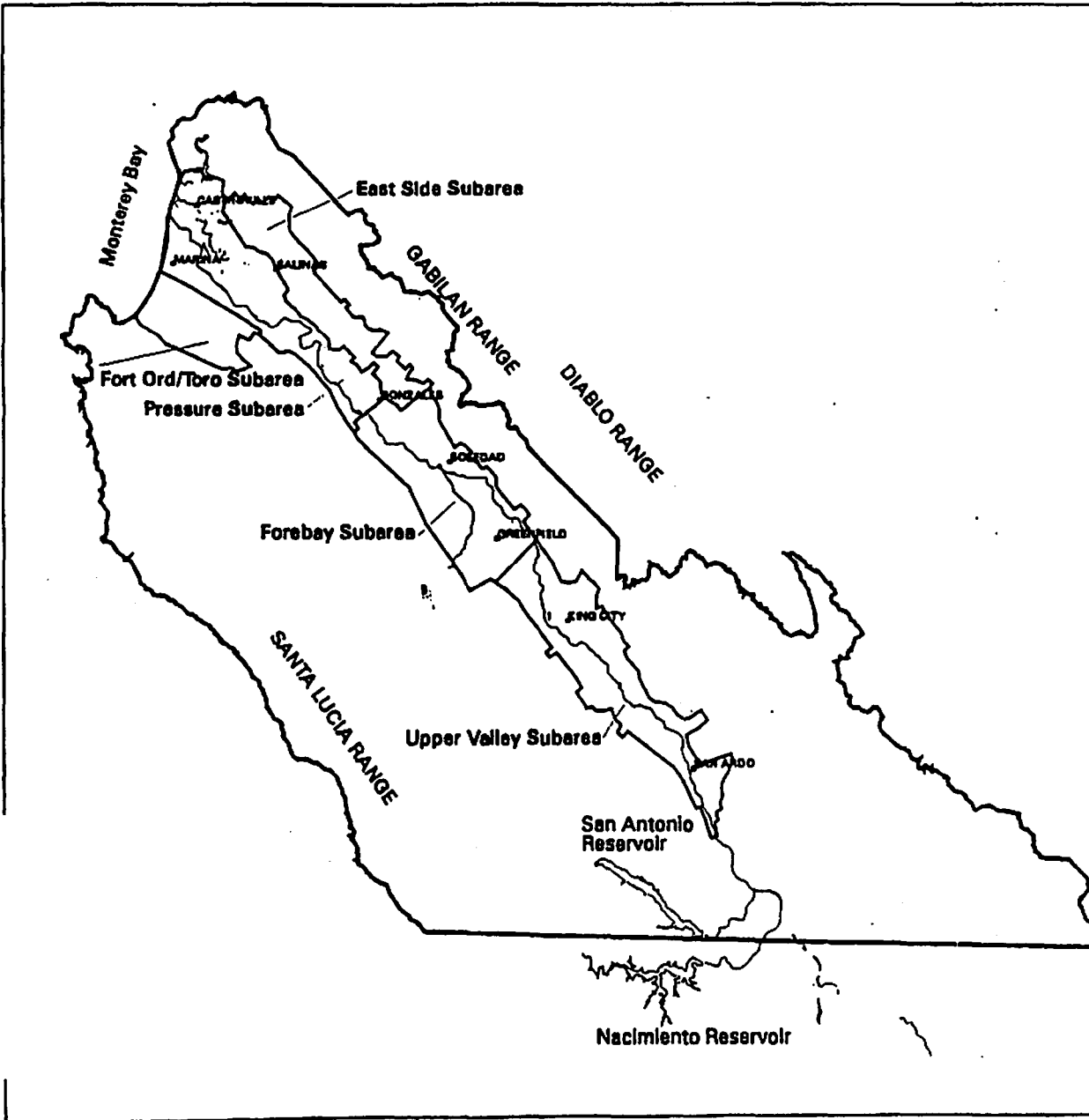

Section 1 - Hydrologic Benefits Analysis

its significance is not well understood.

- **East Side Subarea:** The East Side Subarea is in the northeast part of the Salinas Valley, east of the Pressure Subarea. Along the northeast side of the East Side Subarea, the boundary of the ground water basin is the contact of the alluvium with the igneous rocks of the Gabilan Range. Along the northwest side of the area, the buried clay-filled gorge that extends inland from near Elkhorn Slough acts as one the ground water basin boundaries. Continuing inland, the muds in the slough act as partial barrier to ground water movement between the Salinas Valley and the Pajaro Valley (Durbin, 1978). On the north, the elevated hilly region of the Prunedale area forms a subbasin boundary. Subsurface flow from the Prunedale area provides limited recharge to the East Side Subarea.
- **Forebay Subarea:** The Forebay Subarea is in the center of the Salinas Valley, southeast of the Pressure and East Side Subareas. In the Forebay Subarea, the southwestern boundary of the ground water basin is the contact of the alluvium with the metamorphic rocks of the Sierra de Salinas. On the northeast side of the Forebay Subarea the boundary is the contact of the alluvium with the outcrop of the igneous rocks of the Gabilan Range (Durbin, 1978). The southeastern portion of the Forebay Subarea is bounded by the Diablo Mountain Range.
- **Upper Valley Subarea:** The Upper Valley Subarea is in the

southernmost part of the Salinas Valley, southeast of the Forebay Subarea. In the Upper Valley Subarea, the southwestern and northeastern limits to the ground water basin are assumed to be the contact of the alluvium and either the Pancho Rico Formation or the Monterey Formation (Durbin, 1978). The Salinas River ground water basin extends to the southern end of Monterey County, near Bradley. There is little evidence of major subsurface inflow contributions to the basin from the upper Salinas Basin in San Luis Obispo County.

The Salinas River ground water basin is made up of three distinct aquifer layers, although not all three layers are present throughout the basin. The three layers are designated the Pressure 180-foot Aquifer, the Pressure 400-foot Aquifer, and the Deep Aquifer within the Pressure Subarea. The layers are unnamed throughout the remainder of the basin and are referred to as "shallow" and "deep" zones within the hydrologic subarea. The aquicludes and aquifers are described below.

- **Salinas Aquiclude:** The Salinas Aquiclude is the uppermost confining layer and consists of a discontinuous layer of clays ranging in thickness from 0 to 100 feet. It defines the Pressure Subarea from Chualar to the coast, where it acts as a semi-confining layer to the Pressure 180-foot Aquifer. Between Chualar and Gonzales, as well as near the coast, the clay lenses appear to be discontinuous.
- **The Pressure 180-Foot Aquifer:** Within the Pressure Subarea, beneath the Salinas Aquiclude is the Pressure 180-foot Aquifer. It ranges

Section 1 - Hydrologic Benefits Analysis

in thickness from about 175 to 250 feet. The Pressure 180-foot Aquifer extends several miles into Monterey Bay, where it crops out in the bay. This exposure to the bay serves as the entry point for seawater intrusion into the aquifer. The Pressure 180-Foot Aquifer is not present in the other subareas because the Salinas Aquiclude is not present. In these areas, the aquifer material is part of the unconfined aquifer which extends throughout the remaining valley. The unconfined aquifer ranges from 200 to 800 feet thick.

- **The Pressure 400-Foot Aquifer:** In the Pressure, East Side, and Forebay Subareas, a discontinuous layer of sands and blue clays called the 180/400-foot Aquiclude acts as a semi-confining layer between the Pressure 180-foot Aquifer and the Pressure 400-foot Aquifer in the Pressure Subarea, and the shallow and deep zones in the other subareas. Beneath this aquiclude is the Pressure 400-foot Aquifer, or deep zones in the other subareas, which ranges in thickness from 200 to 250 feet. Early studies did not identify the 400-foot Aquifer south of the Pressure Subarea. It was extended south to include the Forebay Subarea based on studies completed in 1992.
- **Deep Aquifer:** A less-permeable deposit called the Deep Aquifer exists beneath the Pressure 400-foot Aquifer in the Pressure Subarea and the deep zone in the East Side Subarea. The Deep Aquifer is the lower-most freshwater bearing deposit in the Salinas Valley, and ranges in thickness from 0 to 900 feet.

SALINAS VALLEY INTEGRATED GROUND WATER AND SURFACE WATER MODEL

The Salinas Valley Integrated Ground Water and Surface Water Model (SVIGSM) is a finite element computer model with the ability to simulate all aspects of the hydrology of the Salinas Valley. Its major features include:

- Simulation of the horizontal and vertical movement of ground water through the multiple confined and unconfined aquifer layers within the Salinas Valley.
- Simulation of the surface water hydrology in the Salinas Valley, including the Salinas River and its major tributaries, and the interaction between these rivers and the underlying ground water basin. Other hydrologic components, such as runoff from precipitation and contribution from minor tributaries also are simulated.
- Simulation of the operations of Nacimiento and San Antonio Reservoirs based on operational rules for flood control, water supply, and minimum flow requirements.
- Simulation of urban and agricultural water use requirements in the Valley using land use, crop requirement, and agricultural practice information. Recharge and return flows from applied water also are simulated.
- Simulation of the volume and geographical extent of seawater

Section 1 - Hydrologic Benefits Analysis

intrusion into the Salinas Valley from Monterey Bay.

Although the SVIGSM is the most comprehensive ground water model developed for the Valley, it is not the first. Other models include the two-dimensional and three-dimensional model developed in 1978 by the U.S. Geological Survey (USGS) and the U.S. Corps of Engineers (Corps) (Durbin, et al., 1978, and Yates, 1982), and the FEGW-14 developed by Boyle Engineering in 1986.

The SVIGSM was originally developed under BMP Task 1.09 (February 1994) as a planning level tool to analyze and manage the ground water resources of the Salinas Valley. The model is used to analyze the hydrologic and operational impacts of the BMP alternatives. Following an intensive MCWRA and public review process of the SVIGSM in 1996 and 1997, which included five all-day public workshops, several refinements were made to the model. These included updates to the land use, agricultural water use, and several modeling parameters. Following the updates, the model was recalibrated to observed historical ground water and surface water measurements to ensure the proper simulation of historical conditions. The update and recalibration process and results were presented to the public and stakeholders in SVIGSM Workshop #5 in March 1997. The model update and recalibration is documented in the Salinas Valley Integrated Ground Water and Surface Water Model Update (Montgomery Watson, 1997).

The functions of the SVIGSM also made it the most appropriate tool for use in the HBA. Its ability to simulate hydrologic conditions under historical

conditions with and without reservoir operations made it an ideal numerical tool for the hydrologic analysis component of the HBA. The results of the hydrologic analysis serve as the basis for the estimates of the economic benefits of the operation of the reservoirs.

Because the simulation period of the SVIGSM prior to its use for the HBA was 1970 to 1994, an extension of the model data sets back to 1949 was required to capture the entire operational period of the reservoirs. In addition, the aquifer parameters were refined in the Arroyo Seco Cone area of the Forebay Subarea using additional data received from some Stakeholders supplemented by data from MCWRA. Table 1-1 summarizes the primary changes to the SVIGSM data sets prior to its use for the HBA analysis. Once the changes were made, a verification process was performed, in which the model results were compared with observed historical conditions. The model simulation of ground water and surface water conditions was consistent with historical observations, verifying a reasonable simulation of historical conditions. A detailed discussion of the model update and verification process is provided in Appendix A.

HISTORICAL BENEFITS ANALYSIS

Approach to Impact Analysis

The goal of the hydrologic benefits analysis is to determine the hydrologic impacts of historical operations of Nacimiento and San Antonio Reservoirs. The focus of the analysis is on components of the hydrologic system that will be evaluated in the Economic Benefits Analysis in Section 3. These components include:

Section 1 - Hydrologic Benefits Analysis

- ground water levels,
- impacts on well performance,
- seawater intrusion, and
- regional ground water quality.

These components were selected because they encompass the major hydrologic and economic benefits provided by the reservoirs. With the exception of impacts on regional ground water quality, impacts on all of the other selected components can be quantified by the SVIGSM, and an economic benefit can be estimated in the Economic Benefits Analysis (EBA) process. Because the ground water quality model simulates the movement of chloride and is not set up to simulate other water quality parameters, such as nitrate and TDS, regional impacts on TDS were evaluated on a qualitative basis using available ground water quality data.

Comparison of Simulations of Historical and "Without Reservoir" Conditions

Hydrologic impacts are assessed by comparing two model simulations, the historical simulation and simulation of the "without reservoir" conditions. As its name implies, the historical simulation replicates historical hydrologic conditions. Historical hydrology, land use, agricultural and urban water use, and reservoir releases are used to simulate the surface water and ground water conditions during 1949-1994 period. The development of model input data, detail model output,

as well as verification of the simulation results with observed historical conditions, is described in Appendix A.

The simulation of "without reservoir" conditions is a hypothetical case that uses the same hydrology, land use, and agricultural and urban water use as the historical simulation, but without the operation of the reservoirs. No storage of water in the reservoirs is simulated, and the rivers are allowed to flow in an unimpaired state. This simulation essentially represents the hydrologic conditions that would have occurred historically if the reservoirs were not in place, assuming that the land and water use development in the Valley for this case, would have been the same as the historical conditions. No attempt was made to estimate changes in factors such as development and water use practices, had the reservoirs not been in place. Comparison of the differences in hydrologic conditions between the historical and the "without reservoir" cases provides a measure of the hydrologic benefits that have occurred as a result of reservoir operations. The results of these comparisons are discussed below.

Although the SVIGSM simulation period extends from water year 1949 to 1994, reservoir operations began in 1958. Therefore, hydrologic conditions are identical in both the historical and "without reservoir" simulation for the 1949-1957 period, and all benefits are analyzed on the 1958-1994 period.

Section 1 - Hydrologic Benefits Analysis

Table 1-1
SVIGSM Data Set Updates for the Historical Benefits Analysis

| Data Set/Parameter | Modification |
|---------------------------------|----------------------------------------------------------------------------------------------------------------------------------------------------------|
| Land Use | Data set extended back to 1949 using Monterey County crop acreage information. |
| Surface Water Diversions | Added Clark Colony diversions from Arroyo Seco (Reported for 1980-94, estimated for 1949-69). |
| Cropping Intensity | Decreased to 1.3-1.5 Crops per acre in 1950s and 1.7-1.9 Crops per acre in 1960s. |
| Irrigation Efficiency | Data set extended identically from 1970s. Irrigation efficiency is identical for all crops except vineyards. |
| Vertical Pumping Distribution | Modified vertical pumping distribution in Pressure Subarea using MCWRA seawater intrusion information. |
| Horizontal Pumping Distribution | Adjusted pumping in the north county and remaining East Side Subarea. |
| Evapotranspiration | Data set extended identically from 1970s, with the exception of truck crops. Growing season for truck crops reduced due to decreased cropping intensity. |
| Aquifer Hydraulic Conductivity | Hydraulic conductivities refined in the Arroyo Seco Cone area based on additional information provided by Stakeholders and MCWRA. |

Ground Water Balance

In order to understand the interrelationship between various components of the ground water flow regime, simulation results from the SVIGSM are summarized into a set of

water balance diagrams. It is imperative to note that the water balance schematics are intended to develop general understanding of the interrelationship between the components of hydrologic cycle in the basin and/or those between different

Section 1 - Hydrologic Benefits Analysis

subareas of the basin. The values associated with the flow directions are intended to show the relative order-of-magnitude and average annual flow values, and may not necessarily reflect the actual subsurface flow in the basin. Figures 1-2 and 1-3 show the valley-wide average annual ground water balances during the 1958 to 1994 period, for the historical and "without reservoir" simulations, respectively. Figures 1-4 and 1-5 show the corresponding average annual ground water balance for each subarea.

The ground water balance diagrams show all of the inflow and outflow components in the ground water basin valley-wide and each subarea. Inflow components include deep percolation (DP), stream recharge (SR), boundary flow (BF), and subsurface flows into a subarea (SF). Outflow components include ground water pumping (GWP), and subsurface flows out of a subarea (SF). The change in fresh ground water storage (DFGW) is defined as the total fresh water inflow to the ground water basin less total fresh ground water outflow. Seawater intrusion, measured as average annual net subsurface flow across the coastline, is not included in the equation. The change in fresh ground water storage is then computed based on the following formula:

$$DFGW = DP + SR + BF - GWP$$

In the case of ground water balance for each subarea, the net subsurface flow between the subarea and the neighboring ones would also be accounted for as follows:

$$DFGW = DP + SR + BF + \text{net SF} - GWP$$

As in the case of the valley-wide ground water balance, the seawater intrusion component, measured as average

annual net subsurface flow across the coastline into the Pressure Subarea is not included in the equation.

Because the hydrologic and land and water use conditions are assumed the same for both the historical and the "without reservoir" simulations, ground water pumping and deep percolation components in the water balance equation also stay the same. The primary differences between the two cases are in the stream recharge and seawater intrusion components. These components would in turn affect the ground water levels in each subarea, resulting in different subsurface flows from one subarea to the other. The ultimate result is a different change in fresh ground water storage in the "without reservoir" case than the historical case.

Figures 1-2 and 1-3 indicate that during the hydrologic period 1958-94, there has been an average of 30 TAF/yr additional recharge from the streams into the ground water basin. This increased recharge is primarily due to the operation of the reservoirs and regulation of flows in the Salinas River. While the recharge through the beds of the Salinas River during the wet periods has not changed substantially, the regulation of flows has caused additional recharge during the irrigation and dry seasons. Based on the simulation results, this estimated additional recharge ranges from 0 TAF in 1975 to 200 TAF in 1977, throughout the Valley.

The additional stream recharge due to the operation of the reservoirs generally results in higher ground water levels. In the coastal areas the increased ground water levels reduce the landward gradient of seawater from the Monterey

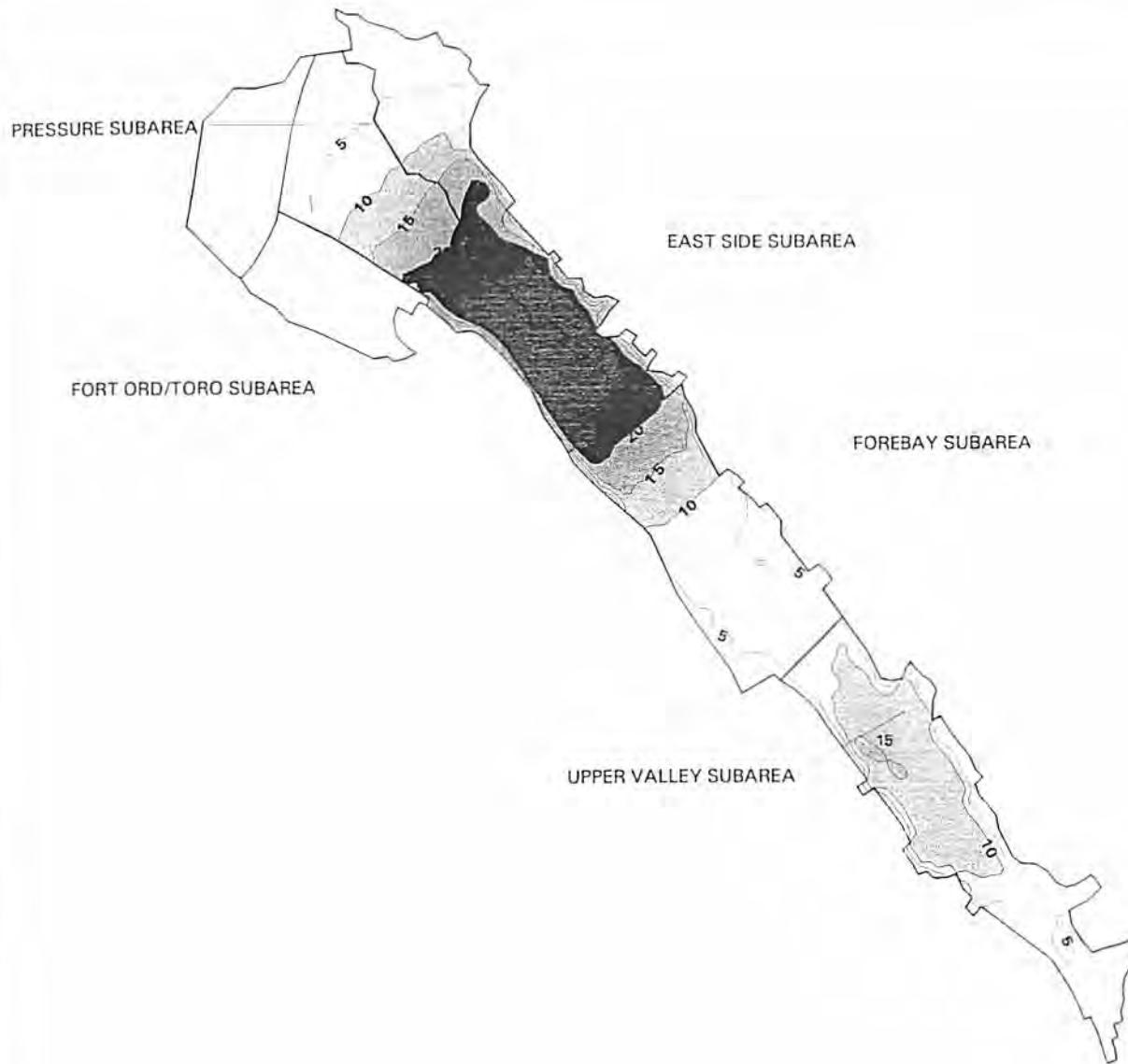
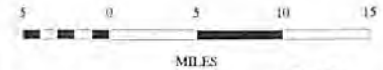

Figure 1-6
Salinas Valley Historical Benefits Analysis
 Average Increase In Ground Water Levels, Historical vs. Without Reservoirs Simulation (1958-1994)

LEGEND

- Subarea Boundaries
- Ground Water Difference Contours
- 0.0 to 4.9 ft
- 5.0 to 9.9 ft
- 10.0 to 14.9 ft
- 15.0 to 19.9 ft
- 20.0 to 24.9 ft
- 25.0 to 29.9 ft



Monterey County
 Water Resources Agency

Source: SVIGSM, 1998

Note: The scale and configuration of all information shown hereon are approximate and are not intended as a guide for design or survey work.

Figure 1-2

Average Annual Ground Water Balance for the Salinas Valley
 Water Years 1958-1994
 Historical Simulation
 (Values Rounded to Nearest Thousands of Acre-Feet)

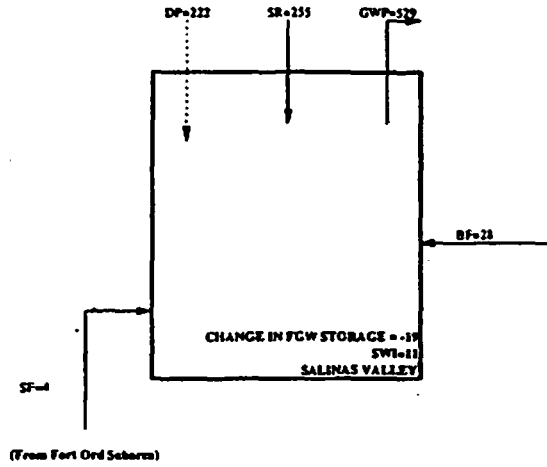
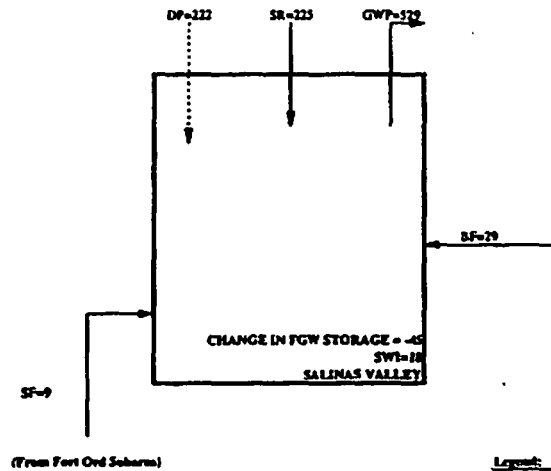

Figure 1-3

Average Annual Ground Water Balance for the Salinas Valley
 Water Years 1958-1994
 Without Reservoir Simulation
 (Values Rounded to Nearest Thousands of Acre-Feet)



Legend:

| | |
|-----|----------------------------------------------|
| FGW | Fresh Ground Water Storage |
| BF | Boundary Flow |
| DP | Drip Percolation from Rain and Applied Water |
| SR | Stream Recharge |
| GWP | Ground Water Pumping |
| SWI | Seawater Intrusion |

Figure 1-4

Average Annual Ground Water Balance by Subarea
 Water Years 1958-1994
 Historical Simulation
 (Values Rounded to Nearest Thousands of Acre-Feet)

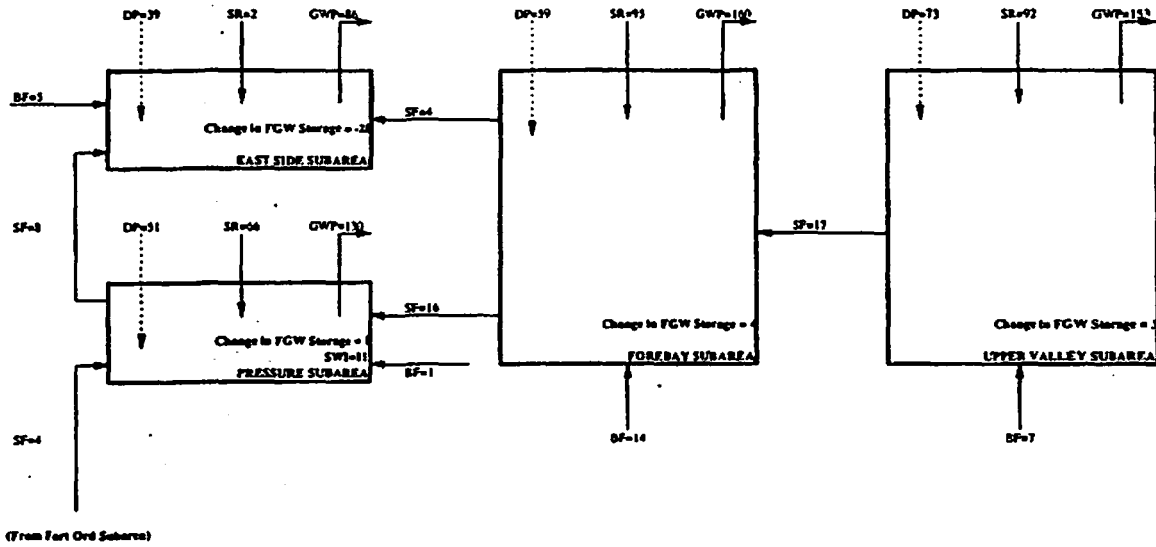
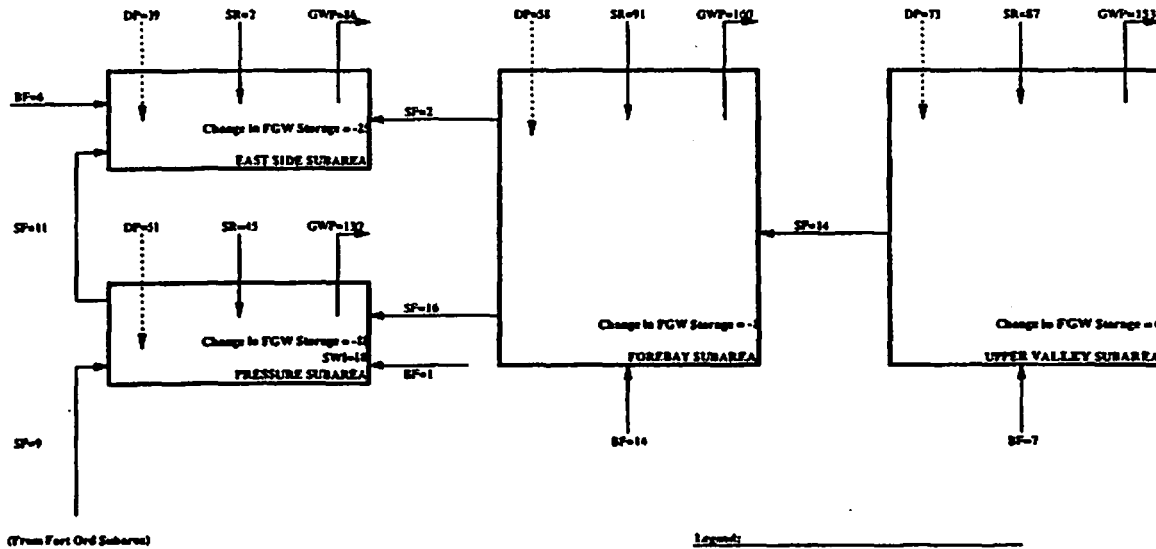

Figure 1-5

Average Annual Ground Water Balance by Subarea
 Water Years 1958-1994
 Without Reservoir Simulation
 (Values Rounded to Nearest Thousands of Acre-Feet)



- Legend:
- FGW Fresh Ground Water
 - BF Boundary Flow
 - DP Deep Percolation from Rain and Applied Water
 - SR Stream Recharge
 - GWP Ground Water Pumping
 - SF Subsurface Flow
 - SWI Seawater Intrusion

Section 1 - Hydrologic Benefits Analysis

Bay into the coastal ground water aquifers. The model simulations indicate that the average annual rate of seawater intrusion, during the period 1958-94, has been 11 TAF under the historical case, while it is 18 TAF under the "without reservoir" case, a reduction of 7 TAF per year, ranging from 1 TAF in 1959 to 10 TAF in 1994. The model simulations also indicate that, during the same period, while the fresh ground water storage in the Salinas Valley has declined at a rate of approximately 19 TAF per year under historical conditions, it would have been declining at approximately 45 TAF per year under the "without reservoir" case.

Similar comparisons can be made between Figures 1-4 and 1-5, which show the ground water balance for each subarea. These figures indicate that under the "without reservoir" case, the average annual stream recharge would have been lower than the historical case by 4 TAF in the Forebay Subarea, 5 TAF in the Upper Valley Subarea, and 21 TAF in the Pressure Subarea. Historical operation of the reservoirs do not appear to affect stream recharge in the East Side Subarea.

As a result of the large reduction in stream recharge, the change in fresh ground water storage decreases from +1 TAF per year to -18 TAF per year in the Pressure Subarea. Similarly, the change in fresh ground water storage drops from +4 TAF to -1 TAF in the Forebay Subarea, and from +3 TAF to 0 TAF in the Upper Valley Subarea. The change in ground water storage shows an increase in the East Side Subarea primarily due to additional subsurface flow from the Pressure Subarea to the East Side Subarea.

Ground Water Levels

A primary benefit of the operations of Nacimiento and San Antonio Reservoirs is the overall improvement of the ground water levels. The ground water levels in a given area directly affect the cost of pumping ground water and well performance in that area, and therefore have a direct economic impact. The Hydrologic Benefits Analysis indicates that the operation of Nacimiento and San Antonio Reservoirs has

- (i) maintained ground water at higher levels,
- (ii) reduced seasonal fluctuations, and
- (iii) reduced the impacts of drought conditions on ground water levels.

No attempt was made to evaluate the effect of increased ground water levels on drainage or agricultural practices.

Determination of Impacts on Ground Water Levels

The impacts on ground water levels as a result of historical operations of the reservoirs are the difference in ground water levels between the historical and "without reservoir" simulations. The SVIGSM calculates static ground water levels at each model node on a monthly basis. Figure 1-6 shows the contours of increases in ground water levels, averaged over the period from 1958 to 1994. Because the primary impact of changing ground water levels is on ground water pumping, which varies throughout the year, the changes in ground water levels shown in Figure 1-6 have been weighted by the distribution of pumping over the irrigation season. Figure 1-7 shows the distribution pattern, which is based on the average monthly distribution of

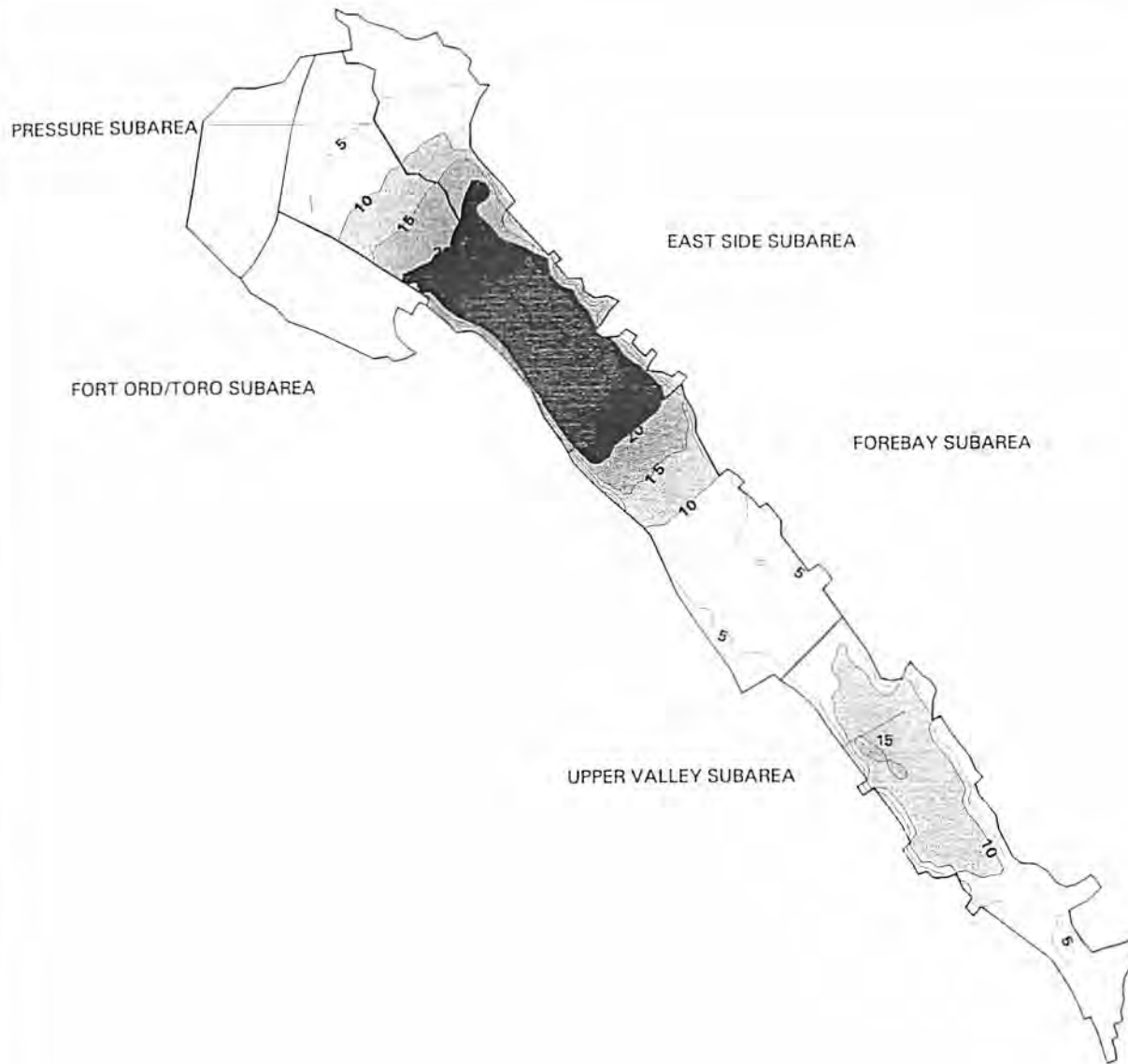
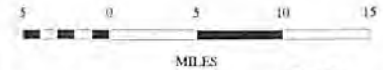

Figure 1-6
Salinas Valley Historical Benefits Analysis
 Average Increase In Ground Water Levels, Historical vs. Without Reservoirs Simulation (1958-1994)

LEGEND

- Subarea Boundaries
- Ground Water Difference Contours
- 0.0 to 4.9 ft
- 5.0 to 9.9 ft
- 10.0 to 14.9 ft
- 15.0 to 19.9 ft
- 20.0 to 24.9 ft
- 25.0 to 29.9 ft



Monterey County
 Water Resources Agency

Source: SVIGSM, 1998

Note: The scale and configuration of all information shown hereon are approximate and are not intended as a guide for design or survey work.

Section 1 - Hydrologic Benefits Analysis

ground water pumping for the entire Salinas Valley.

Figure 1-6 shows that increases in ground water levels in the Pressure and East Side Subareas range from 5 feet near the coast to 25 feet south of Salinas. The northern regions of the Forebay Subarea show increases of 25 to 30 feet, while a large portion of the subarea in the vicinity of the Arroyo Seco Cone shows a 5 to 10-foot increase. Because a majority of the recharge in the Arroyo Seco Cone area comes from stream flows in the Arroyo Seco, which are identical in the historical and "without reservoir" simulation, the changes in ground water levels in this area are less than areas which are more heavily under the influence of the Salinas River recharge.

The Upper Valley Subarea also can be separated into two distinct areas of impact. The northern area shows a change in ground water levels between 5 to 20 feet. In the southern parts of the Upper Valley, where the Salinas River flows during many months, even under the "without reservoir" conditions, the increases in ground water levels due to operation of reservoirs are limited to 5-10 feet.

Nacimiento and San Antonio Reservoirs are operated to store winter runoff, and make releases during the irrigation

season and post-irrigation season, when ground water levels are lowest and recharge potential is highest. Therefore, one of the major benefits of the reservoir operations is increased stream recharge along the Salinas River. This is the reason that the benefits to ground water levels shown in Figure 1-6 concentrate along the Salinas River, and propagate away from the river. Analyses of individual wet and dry years further reveals information on temporal and spatial variability of the recharge benefits. This analysis shows that the benefits are more highly concentrated along the Salinas River during the dry years, and benefits spread out, away from the river in wet years. In addition, changes in ground water levels due to river recharge are greater in the drier years, because very little or no stream flow is available for recharge during the irrigation season without the storage capability of the reservoirs.

The difference between the average monthly Salinas River flow patterns in the historical and "without reservoir" simulations at Bradley, Soledad, and Spreckels are shown in Figures 1-8 through 1-10. The plots show that under historical conditions, Salinas River flows are lower during the winter months, but higher during the irrigation season, when recharge potential is higher.

Figure 1-7
Average Monthly Pumping Distribution Weighting Factor

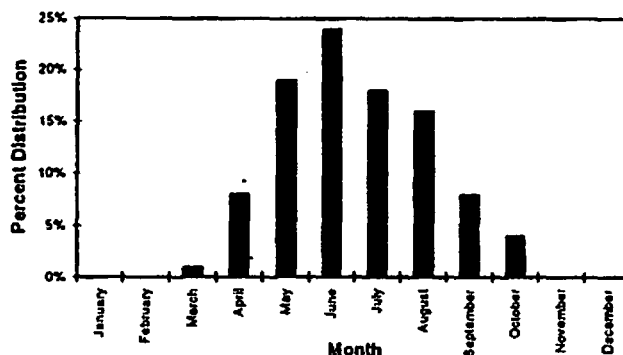

This difference in the Salinas River flow pattern under reservoir operations is the primary reason for increased recharge in the historical simulation. Note that the Figures also show an increase in winter time streamflow between Bradley and Soledad, under the historical conditions. This increased flow in winter period is primarily due to the change in flow regime as a result of operation of the reservoirs, which has caused some reaches of Salinas River in the Forebay and Upper Valley to be gaining reaches.

Figure 1-11 shows the cumulative increase in stream recharge due to reservoir operations. The cumulative difference in stream recharge for the 1958-1994 period is approximately 1.1 million acre-feet (30,000 AFY). The cumulative decrease in Salinas River outflow to the ocean, measured as flow at Spreckels, is 1.8 million acre-feet (49,000 AFY), as shown in Figure 1-12. The difference is approximately 0.7 million acre-feet (19,000 AFY) which is attributed to evaporation from the surface of reservoirs, and reservoir dead storage.

Development of Economic Study Unit Boundaries

In past applications of the SVIGSM, analyses have been broken down geographically by the four hydrologic subareas: Pressure, East Side, Forebay, and Upper Valley. In performing the hydrologic and economic analysis, it became evident that benefits varied widely within each hydrologic subarea, and that presenting information by hydrologic subarea would mask these variations. Therefore, the hydrologic subareas were broken down into smaller Economic Study Units (ESUs). The ESUs (Figure 1-13) are defined to group areas within a hydrologic subarea with similar ranges of impacts, as defined by average annual changes in ground water level.

As shown in Figure 1-13, the SVIGSM model area was divided into 12 ESUs. ESU 11 (north county area) is not considered in this study, because it is not within the Zone 2/2A boundaries. The Fort Ord Subarea of the model is not included in the analysis because it is not believed to be part of the main ground water basin, and due to lack of data on both the hydrologic definition

Figure 1-8

Average Monthly Salinas River Flows at Bradley
1958-1994

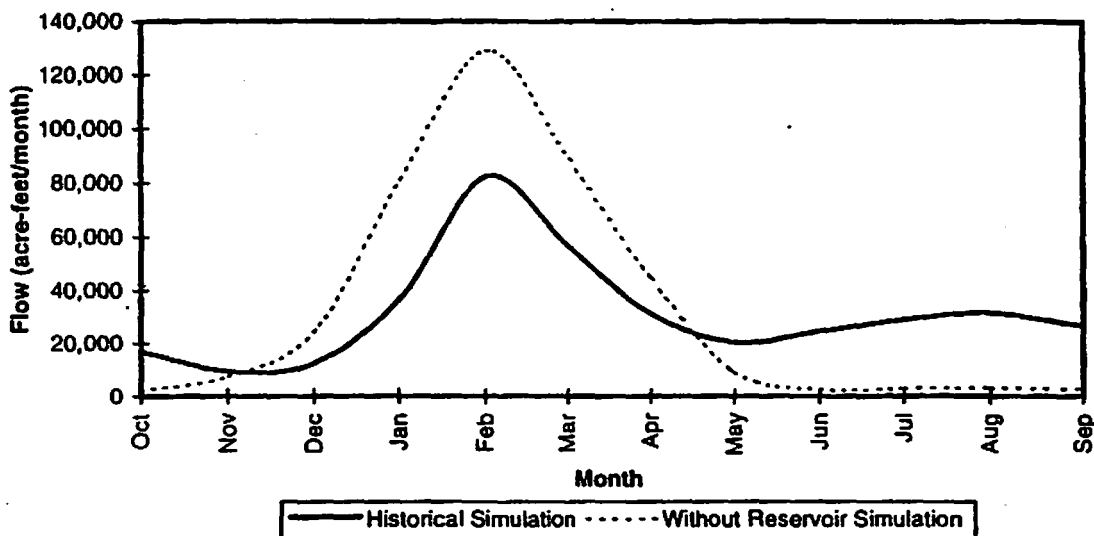

Figure 1-9

Average Monthly Salinas River Flows at Soledad
1958-1994

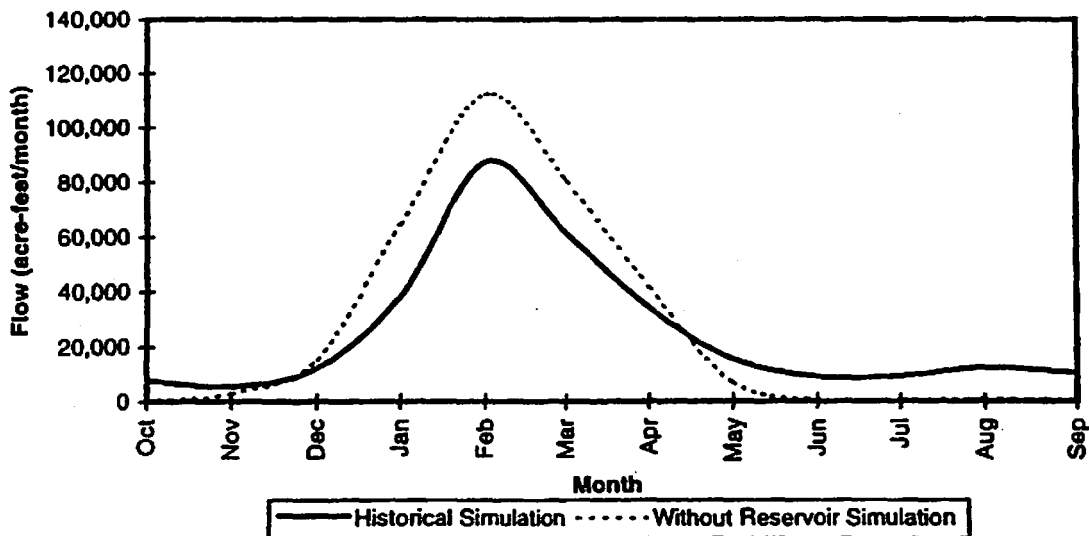

Figure 1-10

Average Monthly Salinas River Flows at Spreckels
1958-1994

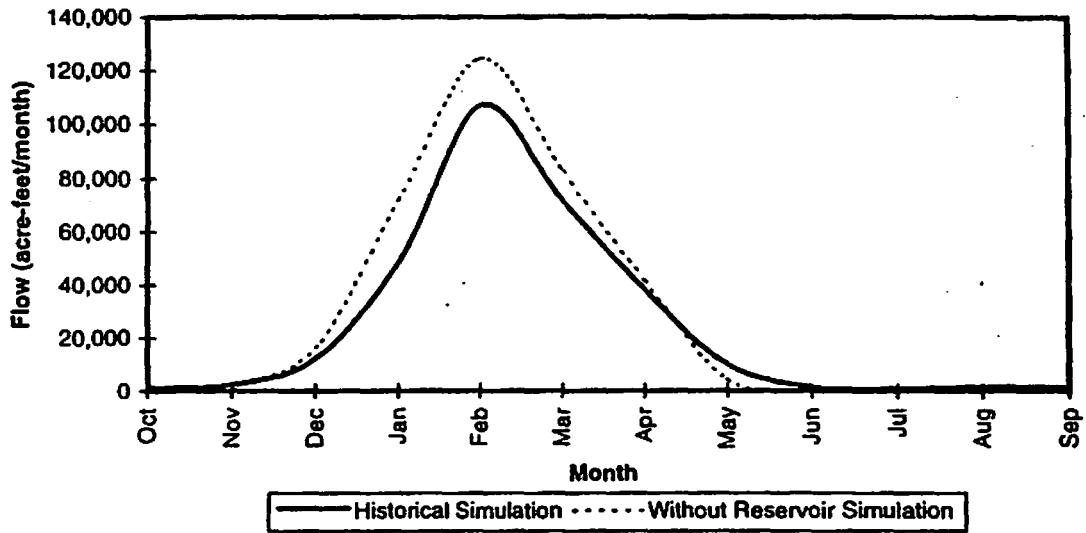

Figure 1-11

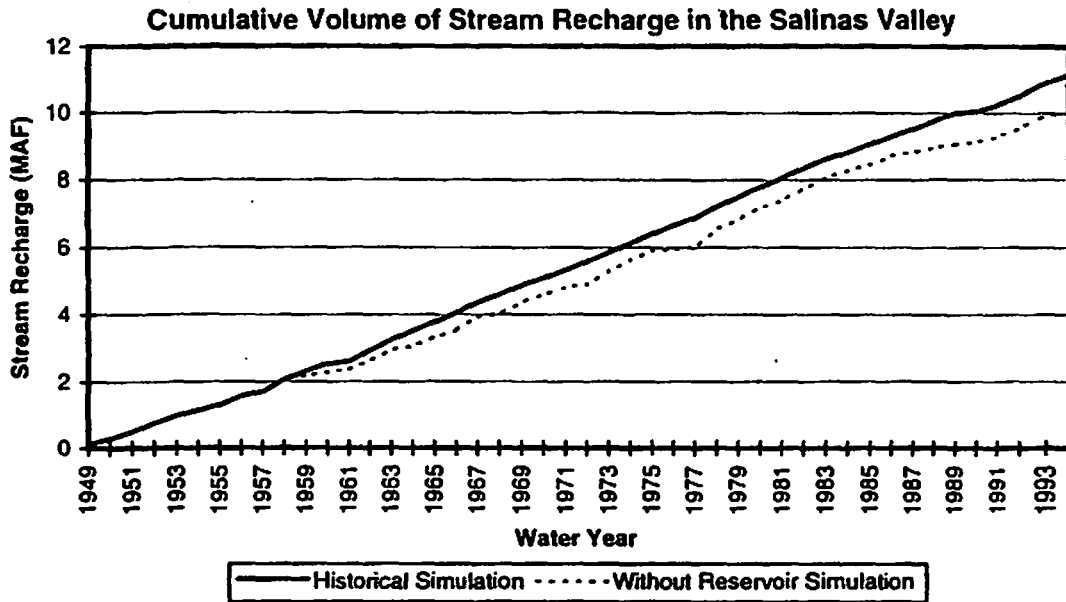
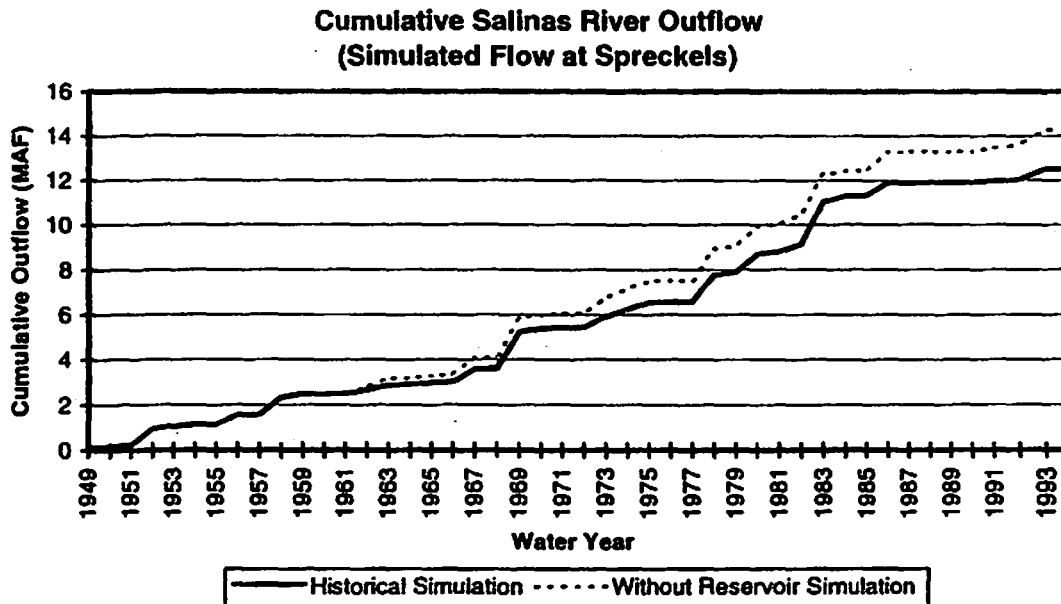

Figure 1-12





AR 07059

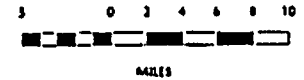
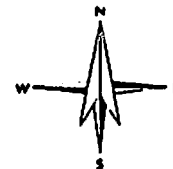

Figure 1-13

**Salinas Valley Historical
Benefits Analysis
Economic Study Unit Boundaries**

LEGEND

- 5** ESU Number
-  ESU Boundaries
-  Rivers
-  Cities



**Monterey County
Water Resources Agency**

Source: MCWRA

Note: The scale and configuration of all information shown herein are approximate and are not intended as a guide for design or survey work.

Section 1 - Hydrologic Benefits Analysis

of the area and ground water level measurements. The Pressure Subarea was divided into ESUs 1, 3, and 5. The East Side Subarea was divided into ESUs 2 and 6. The Forebay Subarea was divided into three ESUs: ESU 7 in the northern part of the Forebay, 8A in the Arroyo Seco Cone, and 8B in the southeastern part of the Forebay. There are no indications that the hydrogeology of the Arroyo Seco Cone area is different from the rest of the Forebay Subarea, nor are the ground water level impacts significantly different from ESU 8B. However, because the ground water basin underlying ESU 8A is mainly replenished by the Arroyo Seco, there was a need to separate this area in accounting of the historical benefits. The Upper Valley Subarea was divided into ESUs 9 and 10. The ESU boundaries were developed to create units with similar hydrologic and economic benefits. The primary benefit criteria used was the long-term average annual change in ground water levels.

The ESU boundaries were developed using the contour map shown in Figure 1-6 and a map with physical features and institutional boundaries. To the extent possible, the boundaries were determined along the major institutional boundaries or physical features. Once the boundaries were determined, they were aligned with SVIGSM element boundaries for modeling purposes.

Changes in Regional Average Ground Water Levels

The estimate of annual avoided ground water pumping cost requires a regional average annual change in ground water level for each ESU. The regional average annual ground water level is

computed by averaging the monthly ground water levels geographically within each ESU, as well as over time. The geographical average is calculated by weighting ground water levels over each ESU by the pumping distribution across the ESU. This geographical average is then averaged over the irrigation season using the monthly weighting factors shown in Figure 1-7. The monthly weighting factors were based on the monthly distribution of ground water pumping over the irrigation season.

Figures 1-14 through 1-23 show hydrographs of the regional average annual ground water levels for each ESU under the historical and "without reservoir" conditions. For all of the ESUs, regional ground water levels under historical conditions begin to rise above those under "without reservoir" conditions in 1958, the beginning of reservoir operations, and are maintained at a higher level overall. In addition, water level declines in dry years (i.e., 1976 to 1977 and 1987 to 1990) are less severe under historical conditions, because reservoir storage is used to carry over water through dry periods for releases to the Salinas River.

Once the hydrographs of regional average annual ground water levels are developed, the long-term averages over the 1958-1994 period for each ESU are used to estimate avoided pumping costs. Table 1-2 summarizes the differences between the historical and "without reservoir" regional average annual ground water levels for each ESU.

Impacts on Well Performance

Changing ground water levels will affect not only pumping costs but also

Figure 1-14

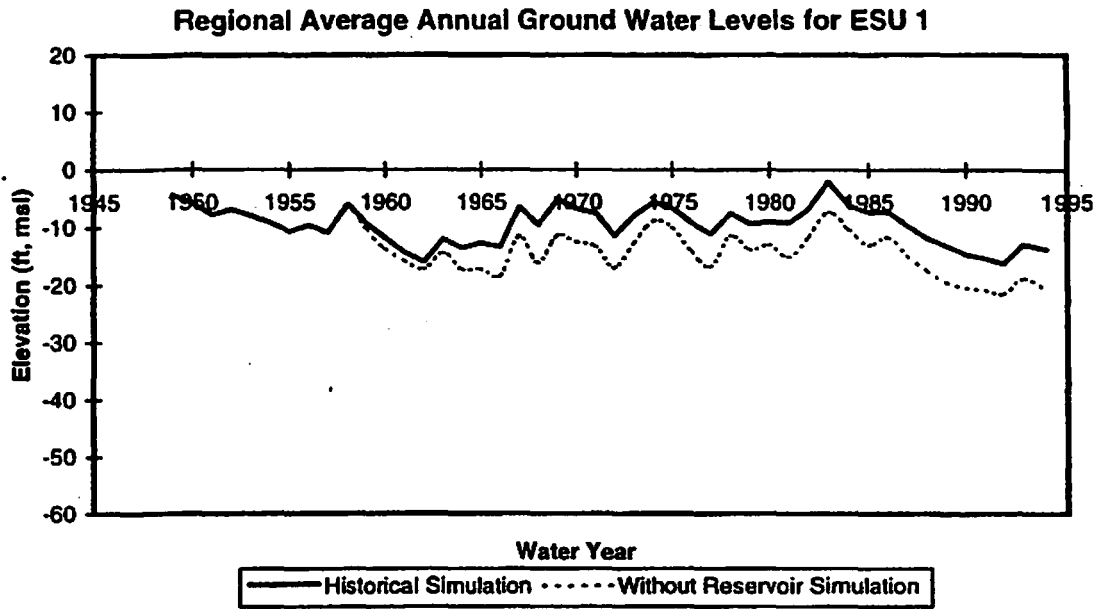

Figure 1-15

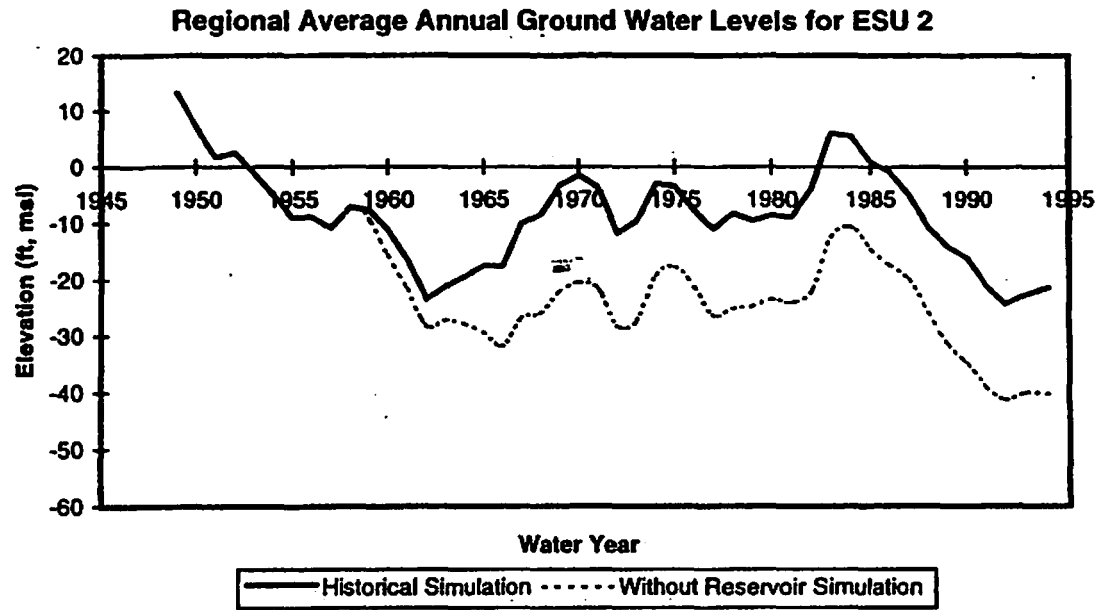

Figure 1-16

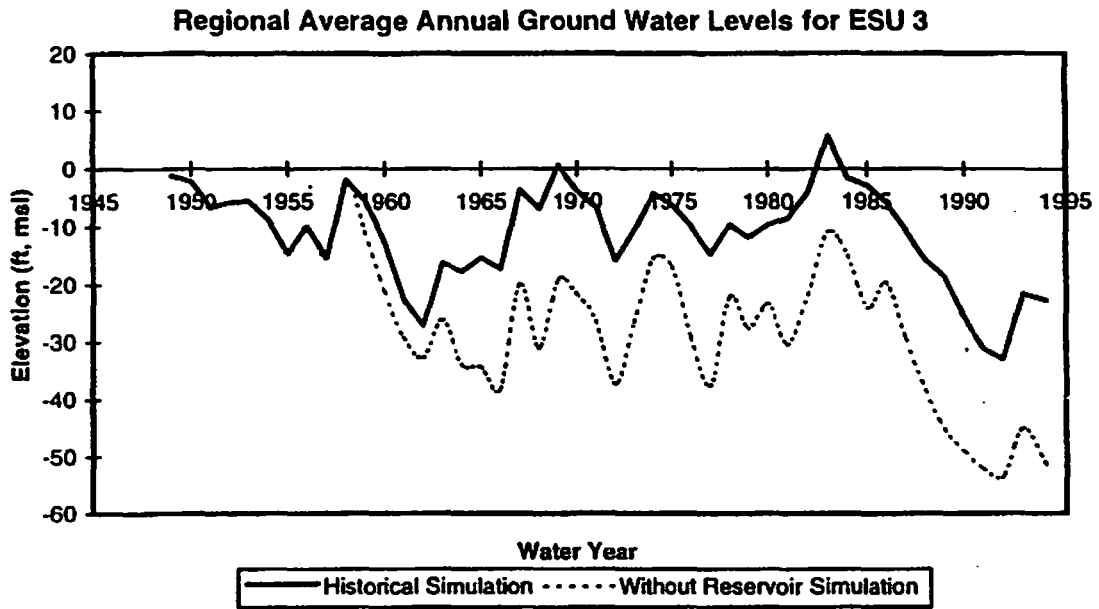

Figure 1-17

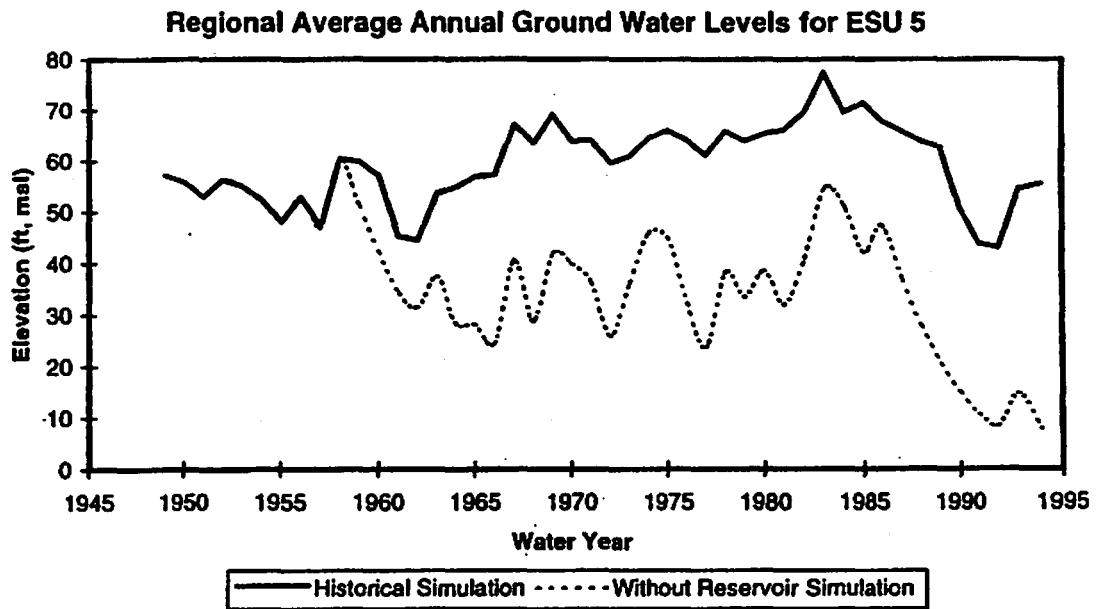

Figure 1-18

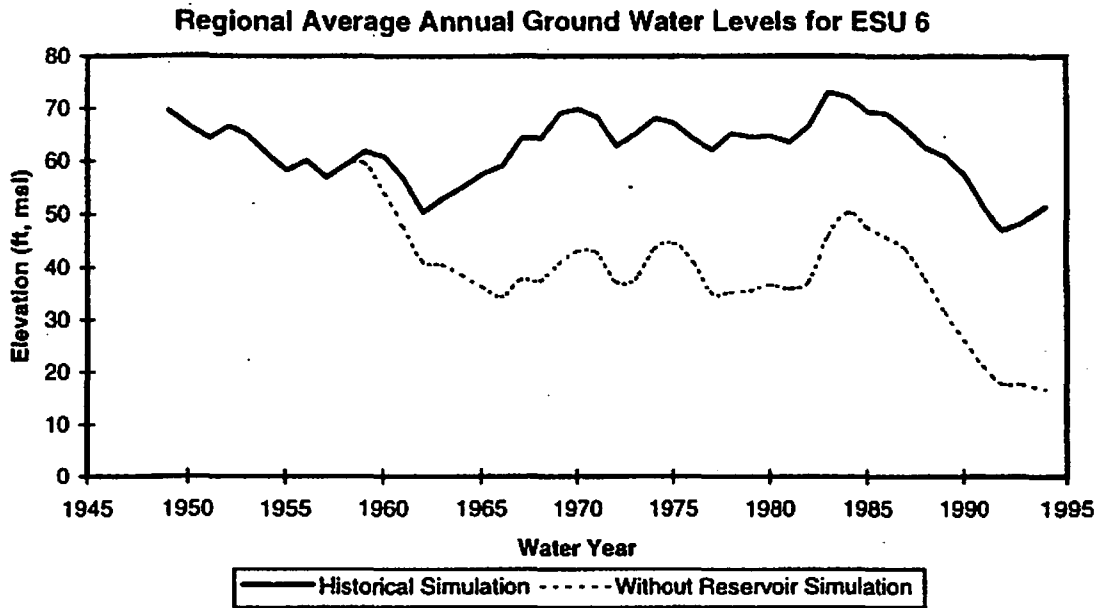

Figure 1-19

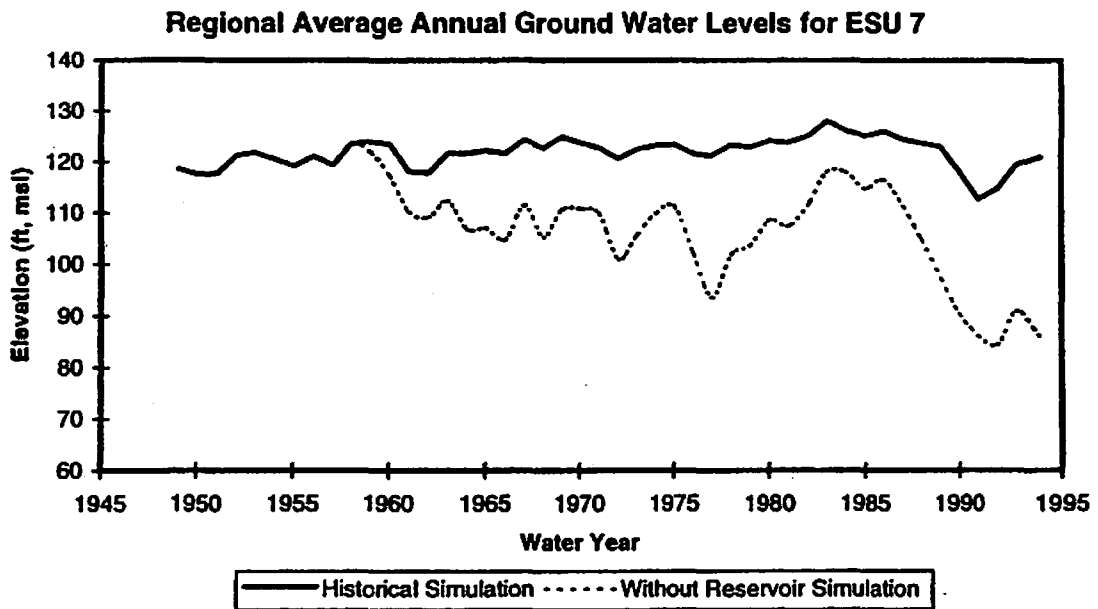

Figure 1-20

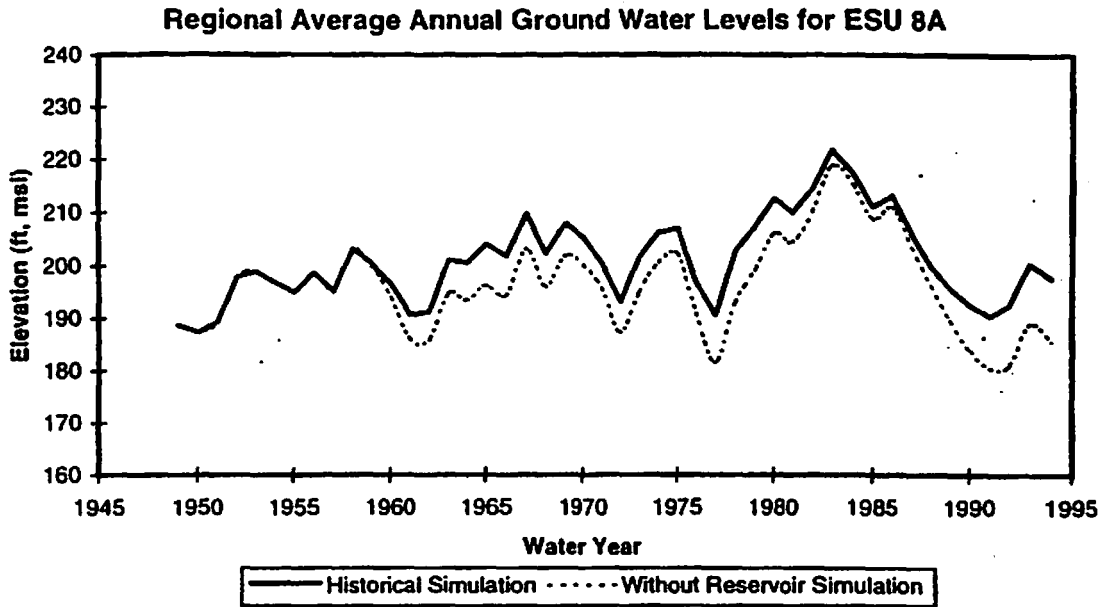

Figure 1-21

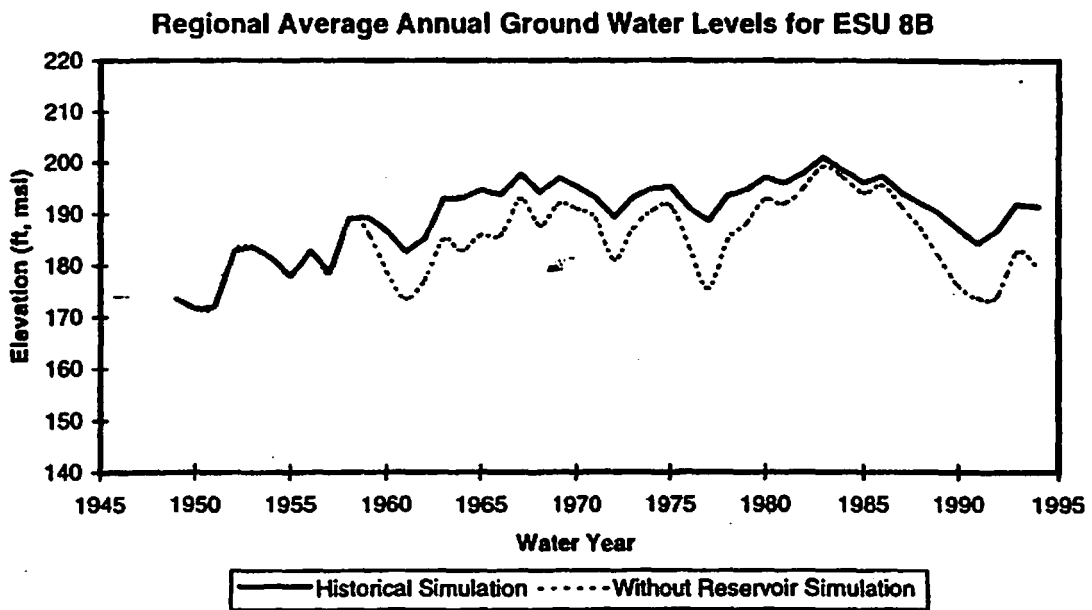

Figure 1-22

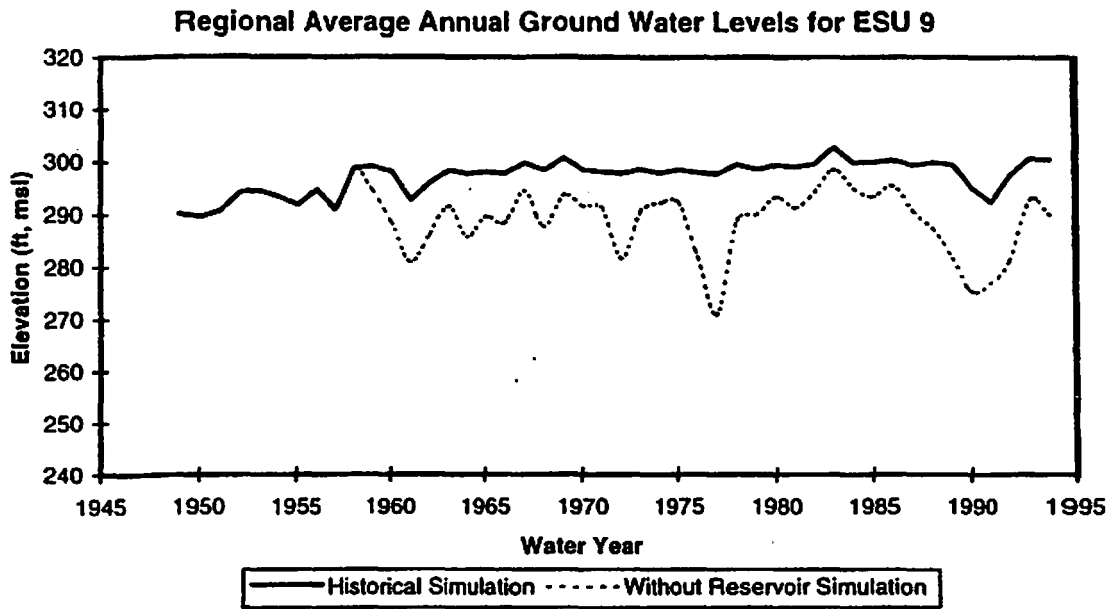
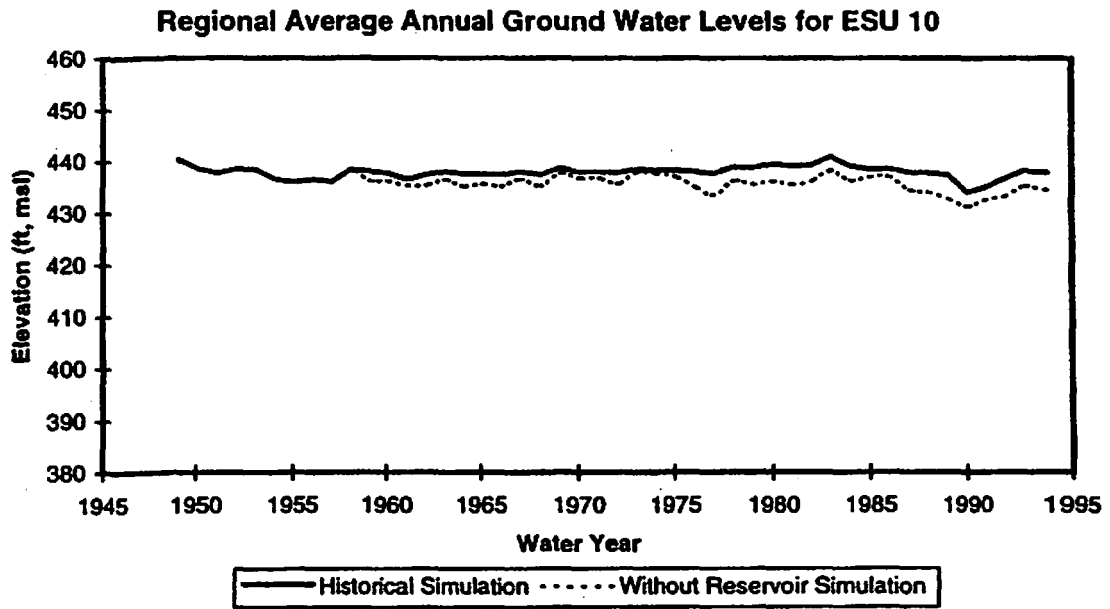

Figure 1-23



Section 1 - Hydrologic Benefits Analysis

may impact the performance of a well if ground water levels begin to drop below the top of well perforations. Small changes in ground water levels can generally be compensated for by modifying pump operations. However, if levels drop even further, and ground water levels drop below the top of the perforation, operational problems may occur. These problems may be compensated for by modifying pump operations to reduce drawdown, or by making minor modifications to the well itself to correct the problem (e.g. lowering pump bowls). If a significant portion of the well perforation becomes dewatered, the impact cannot be corrected with minor physical or operational modifications to the well. An additional well will be necessary to either replace or supplement the existing well.

The degree of impact on a well depends on the degree of change in ground water levels and the construction details of the well. An analysis methodology was developed to determine the potential impacts on the performance of the wells in the Salinas Valley that would result under "without reservoir" conditions. The impacts of changing water levels on the wells in the Salinas Valley are evaluated at three levels, from a strictly hydrologic standpoint, from a well performance standpoint, and ultimately from an economic standpoint. This section addresses the hydrologic and well performance impacts; Section 3 addresses the economic impacts.

Hydrologic Impact on Wells

The approach used to determine the degree of impact from a strictly

hydrologic standpoint was to compare the construction details for a sample group of wells with the estimated ground water levels at those wells. The decline of the ground water levels below the well perforations was used as the criterion to define a hydrologic impact on the well.

The sample group of wells used in the analysis consisted of all wells in the MCWRA well database with detailed well construction and well location information, including well depth, perforation intervals, and location coordinates. A total of 384 wells were included in the sample group, 185 in the Pressure Subarea, 84 in the East Side Subarea, 65 in the Forebay Subarea, and 50 in the Upper Valley Subarea. Figure 1-24 shows the locations of the wells in the sample group. Overall, the sample group represents relatively good coverage of most areas of the Salinas Valley. Because dividing the wells in each subarea into the respective ESU would yield too few wells in each ESU from a statistical standpoint, all of the analysis was carried out on a subarea basis. The results of the analysis for each subarea was then applied uniformly to all ESUs in that subarea.

The average annual ground water levels for the 1958-1994 period were used to determine which wells would be impacted. For both historical and "without reservoir" conditions, static ground water levels at each well in the sample group were adjusted by an appropriate drawdown to determine pumping water levels. Drawdowns were estimated using well capacity and specific capacity data provided by MCWRA. Table 1-3 shows the estimated drawdowns for each subarea.

Figure 1-24

**Location of Sample Wells
Used for Well Impact Analysis**

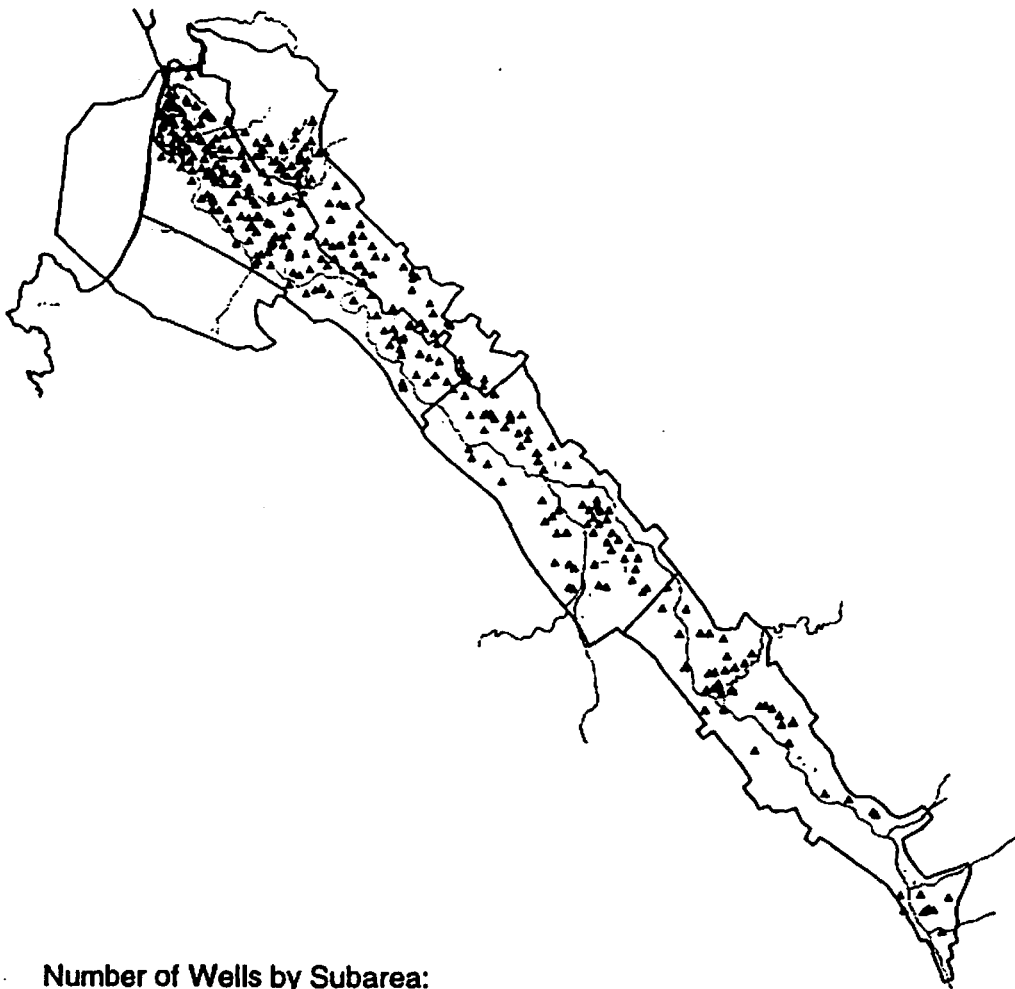

Number of Wells by Subarea:
Pressure Subarea: 185 Wells
East Side Subarea: 84 Wells
Forebay Subarea: 65 Wells
Upper Valley Subarea: 50 Wells

Section 1 - Hydrologic Benefits Analysis

**Table 1-2
Regional Average Annual Ground Water Levels
Long-Term Average, 1958-1994**

| ESU | Increase in Regional Average Annual Ground Water Levels With and Without Reservoirs (feet) | | |
|-----|--------------------------------------------------------------------------------------------------|---------------------|---------------------|
| | Minimum Increase | Maximum Increase | Average Increase |
| 1 | 1.1 | 7.0 | 4.5 |
| 2 | 1.6 | 19.0 | 14.2 |
| 3 | 5.5 | 28.6 | 16.9 |
| 4 | N/A | N/A | N/A |
| 5 | 8.7 | 47.8 | 26.9 |
| 6 | 2.3 | 34.9 | 23.3 |
| 7 | 2.1 | 35.1 | 16.0 |
| 8A | 0.6 | 11.9 | 5.9 |
| 8B | 1.4 | 13.2 | 6.4 |
| 9 | 4.2 | 26.7 | 9.7 |
| 10 | 0.6 | 4.7 | 2.3 |
| 11 | N/A | N/A | N/A |

**Table 1-3
Estimated Well Drawdowns**

| subarea | Estimated Drawdown (feet) |
|--------------|------------------------------|
| Pressure | 23 |
| East Side | 46 |
| Forebay | 30 |
| Upper Valley | 30 |

The pumping levels under historical and "without reservoir" conditions were compared to the perforation intervals for all of the wells in the sample well group. Wells for which pumping levels dropped 10 feet below the top of the first (highest) perforation interval were considered to be impacted. The 10-foot criteria was used to account for the regional nature of the

SVIGSM. Because the model was developed to estimate ground water conditions on a regional level, and not on a well site specific-level, using a 10-foot buffer zone accounts for regional differences in ground water levels.

A total of 19 wells were incrementally impacted in the "without reservoir" simulation. These wells were found to

Section 1 - Hydrologic Benefits Analysis

meet the impact criteria, and are considered to be impacted strictly from a hydrologic standpoint. Further analysis was performed to determine any real impact on well performance.

Figures 1-25 through 1-43 show the well perforation intervals and monthly pumping ground water levels for each of the 19 wells determined to be impacted from a hydrologic standpoint. A more detailed comparison of well construction details and monthly ground water levels was performed, and the 19 wells were grouped into three levels of potential impacts on well performance. Wells with Level 1 impacts were considered operational under the "without reservoir" conditions, with minimal performance impacts. Wells with Level 2 impacts required modifications to the well construction to maintain operation of the well (i.e., lowering of pump bowls). For wells with Level 3 impacts, modifications would not be sufficient to maintain operation of the well, and another well would have to be drilled to either replace or supplement the impacted well. The results of the detailed analysis of well performance impacts is provided in Table 1-4.

A summary of the well performance impact analysis by subarea is provided in Table 1-5. The total number of wells in the sample well group, the number of wells with hydrologic impacts, and the number of wells with performance impacts are provided. Because the results of the analysis of the sample well group will be extrapolated to all of the wells in each subarea, the number of impacted wells as well as the fraction of the sample group impacted are provided.

Based on Table 1-5, the percent of production wells requiring equipment modification are 1.6% and 1.2% in Pressure and East Side Subareas, and none in Forebay and Upper Valley. Table 1-5 also shows that in the Upper Valley Subarea 8% of the wells would require drilling a deeper replacement well, in order to minimize the impacts of drought conditions, and ensure a reliable water supply. In other areas of the Valley, well replacement is not required. This is due to the fact that changes in ground water levels during drought conditions was not significant enough, and/or the screen intervals are large enough and would not be impacted by the ground water level changes during drought.

In the Upper Valley, where most wells are relatively shallow, more of wells are impacted. In order to ascertain that ground water of reasonable quality and yield to wells is available, if the new replacement wells were to be drilled deeper, a review of literature on the geology of the Upper Valley was made. The following three sources were reviewed:

- Montgomery Watson (1994) report on BMP Task 1.09,
- USGS (1974) report on the "Geology of the Southern Salinas Valley Area", and
- USGS (1986) "A Water Resources Data Network Evaluation for Monterey County",

Based on these literature, there is no substantial evidence that would preclude drilling wells deeper or indicate problems with water quality at deeper zones in Upper Valley.

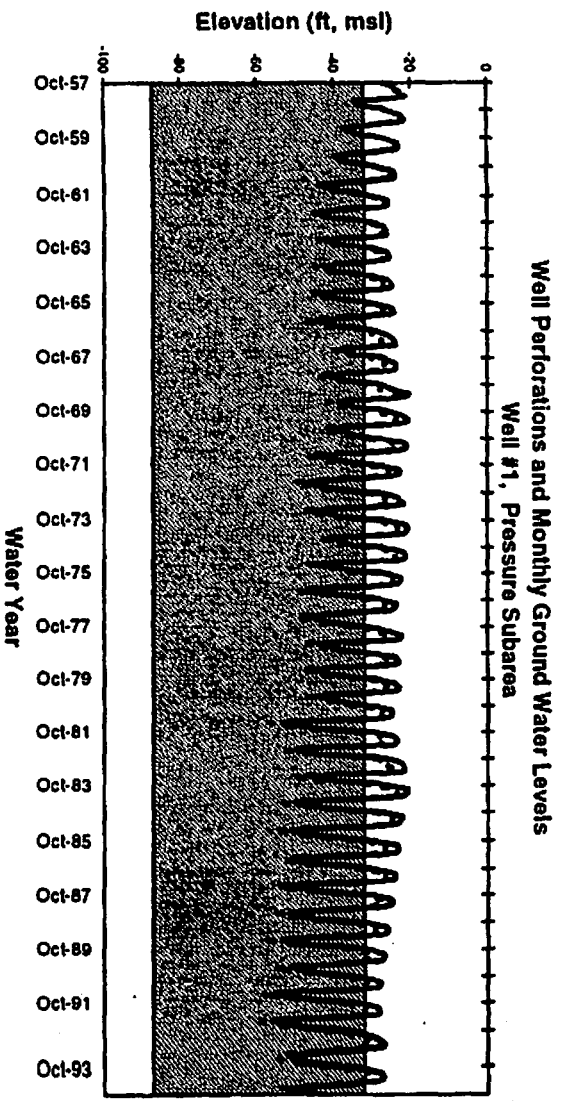

Figure 1-25

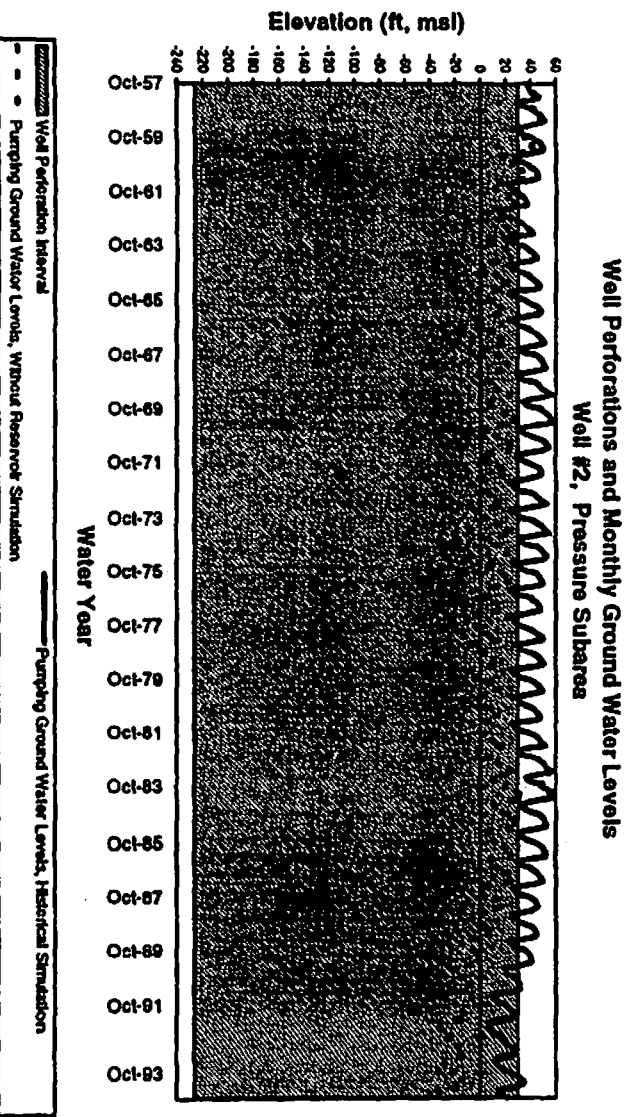

Figure 1-26

Figure 1-27

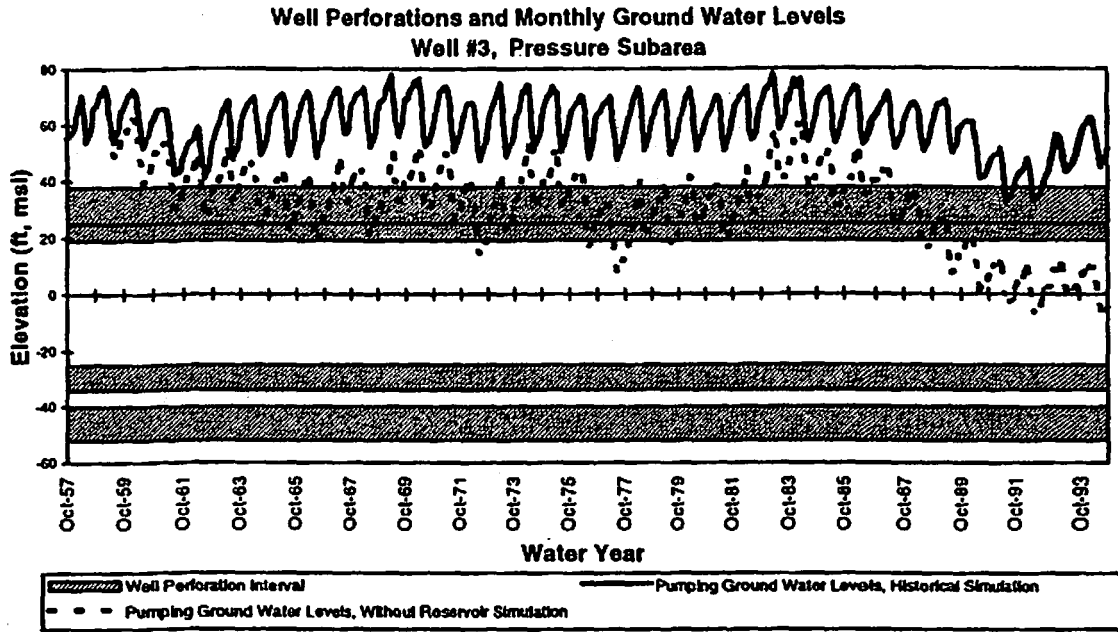

Figure 1-28

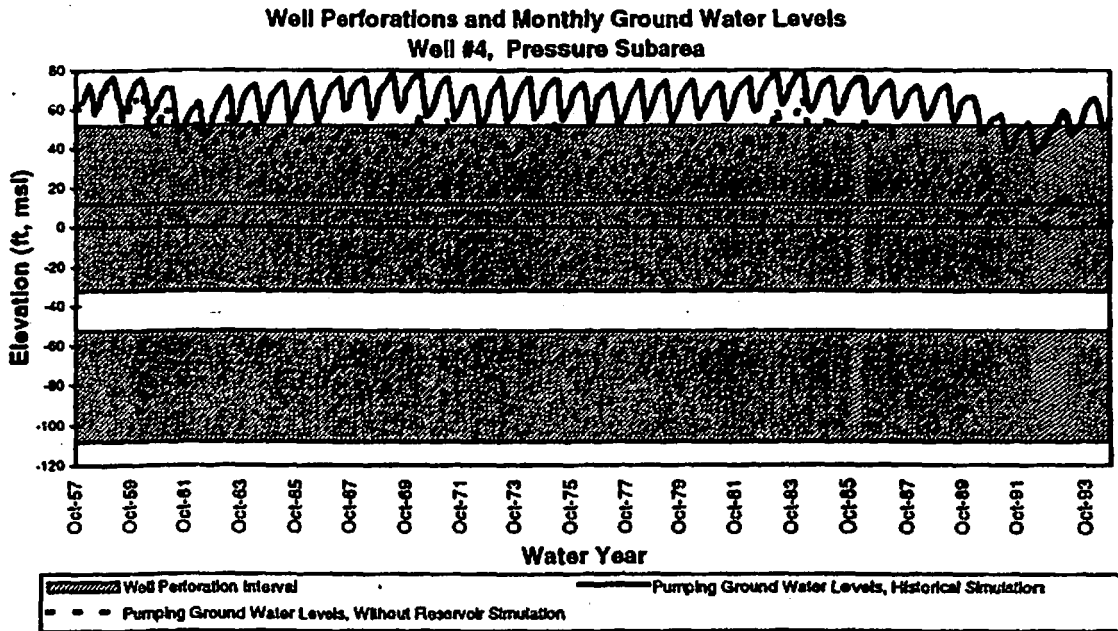

Figure 1-29

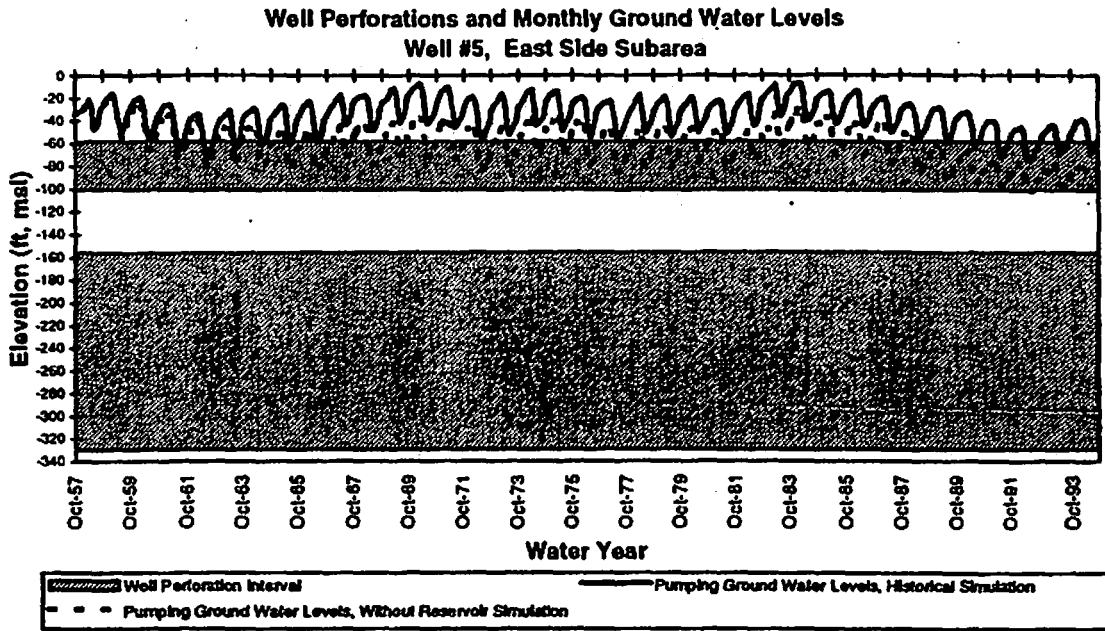

Figure 1-30

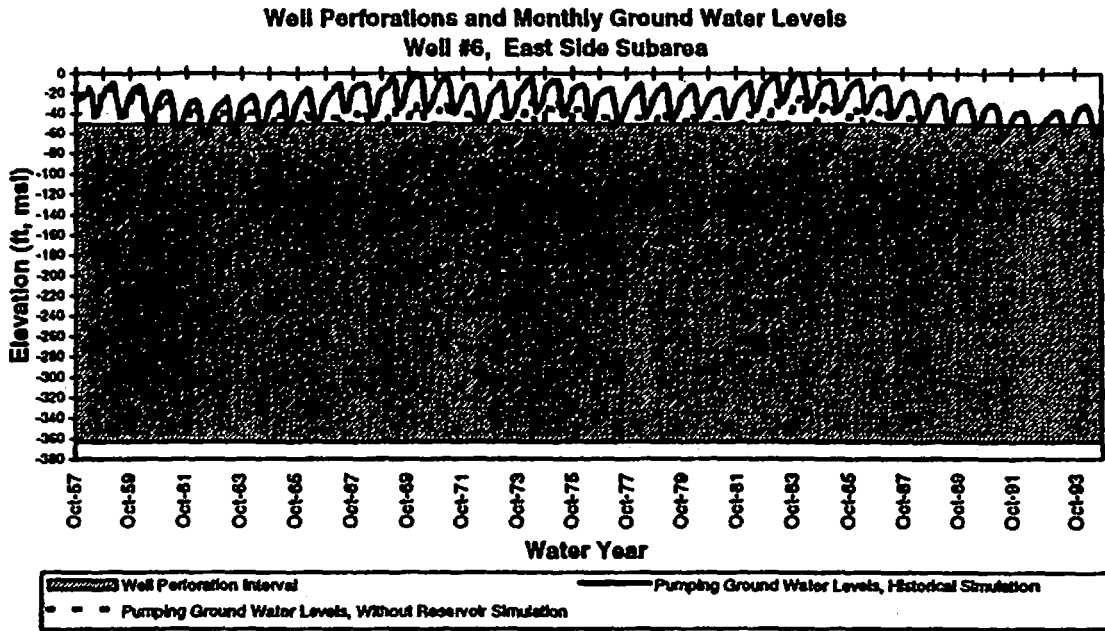

Figure 1-31

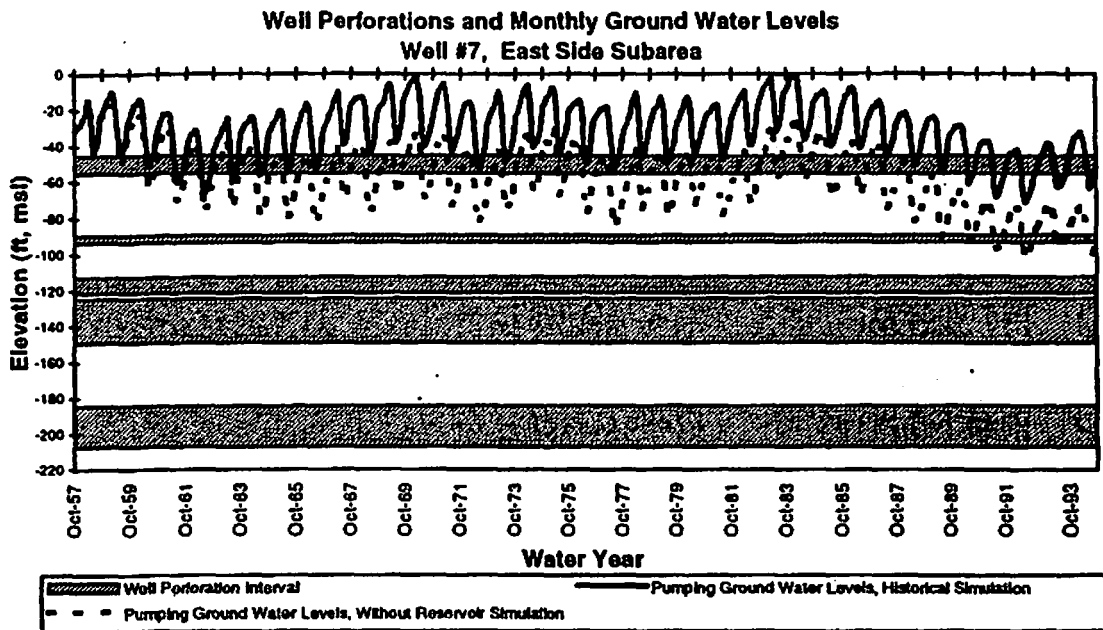

Figure 1-32

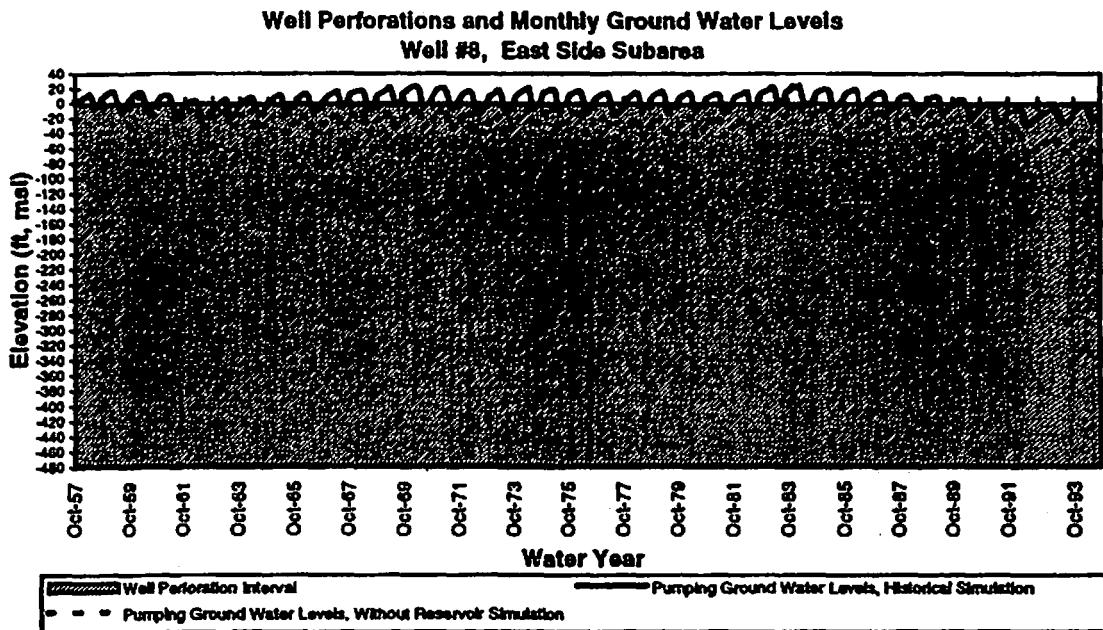

Figure 1-33

Well Perforations and Monthly Ground Water Levels
Well #9, East Side Subarea

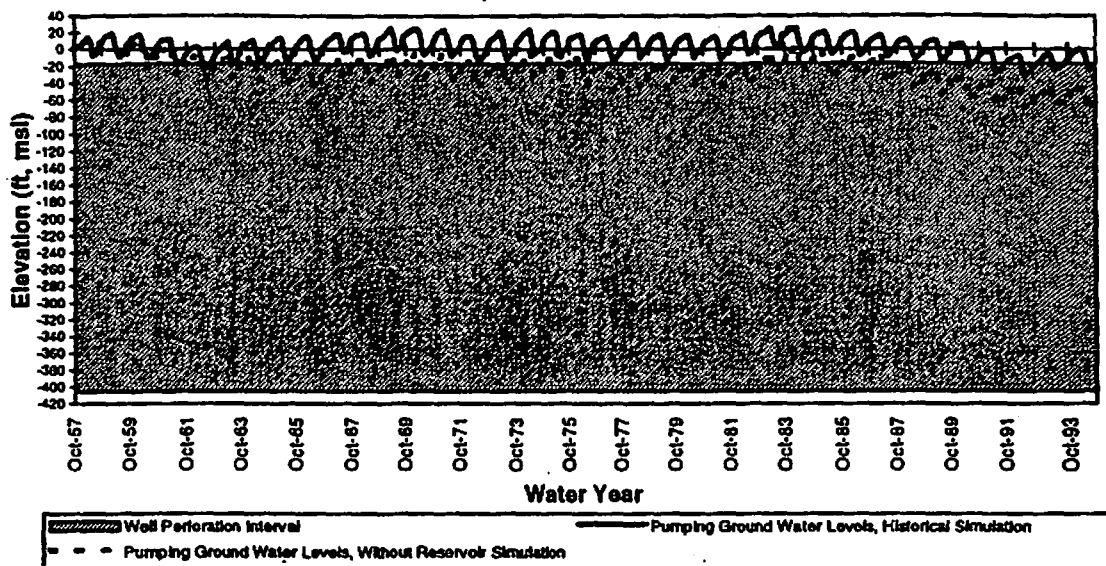

Figure 1-34

Well Perforations and Monthly Ground Water Levels
Well #10, Forebay Subarea

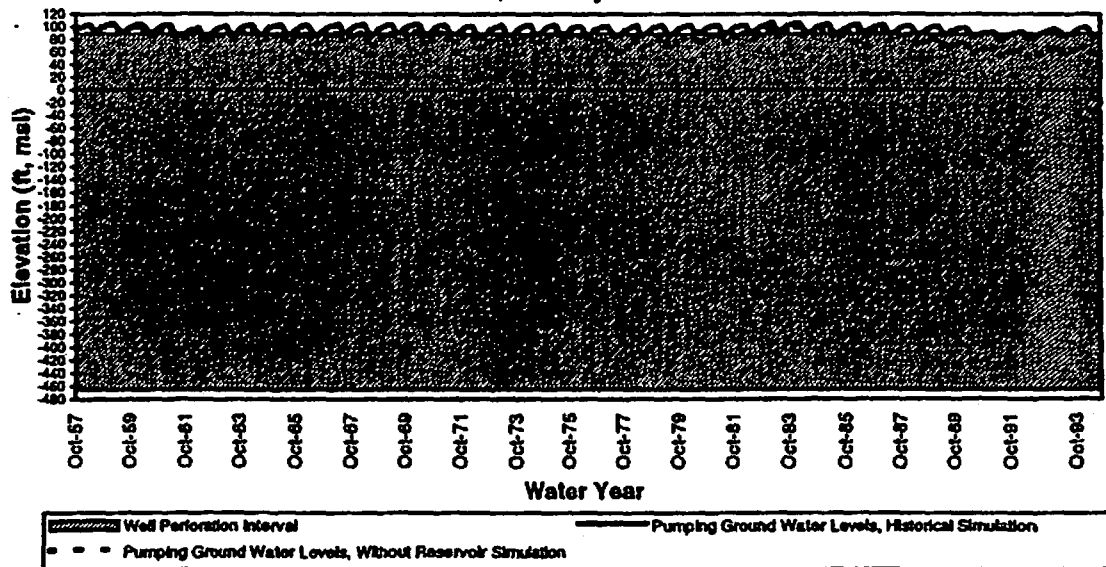

Figure 1-35

Well Perforations and Monthly Ground Water Levels
Well #11, Forebay Subarea

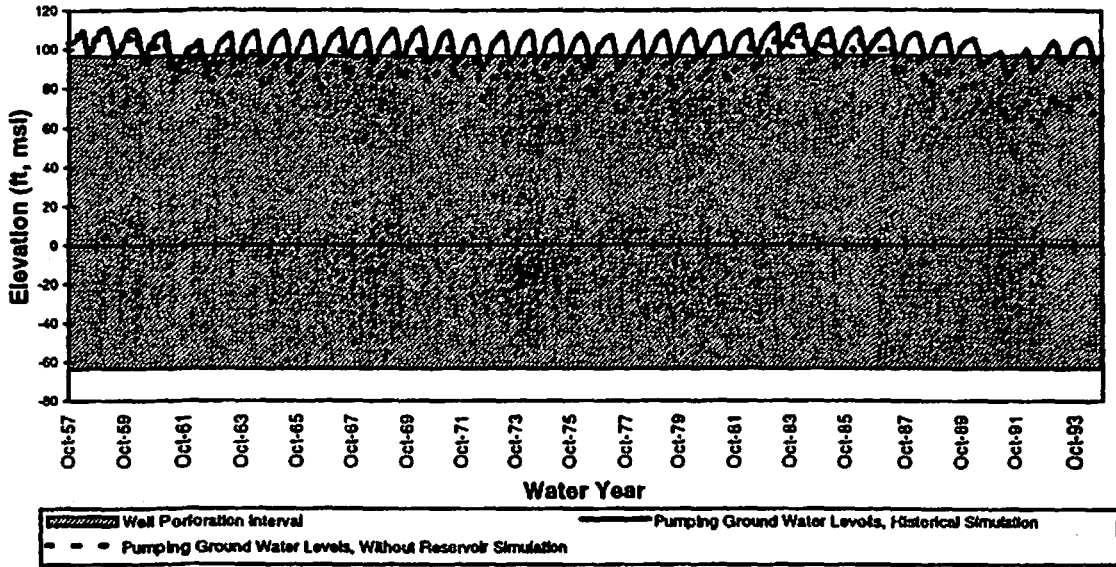

Figure 1-36

Well Perforations and Monthly Ground Water Levels
Well #12, Forebay Subarea

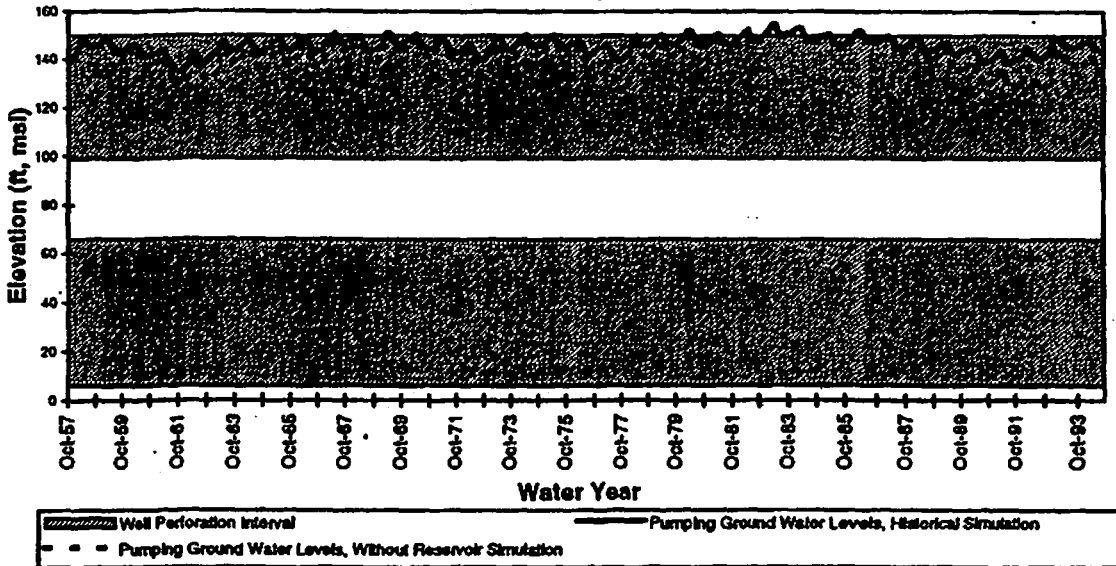

Figure 1-37

Well Perforations and Monthly Ground Water Levels
Well #13, Forebay Subarea

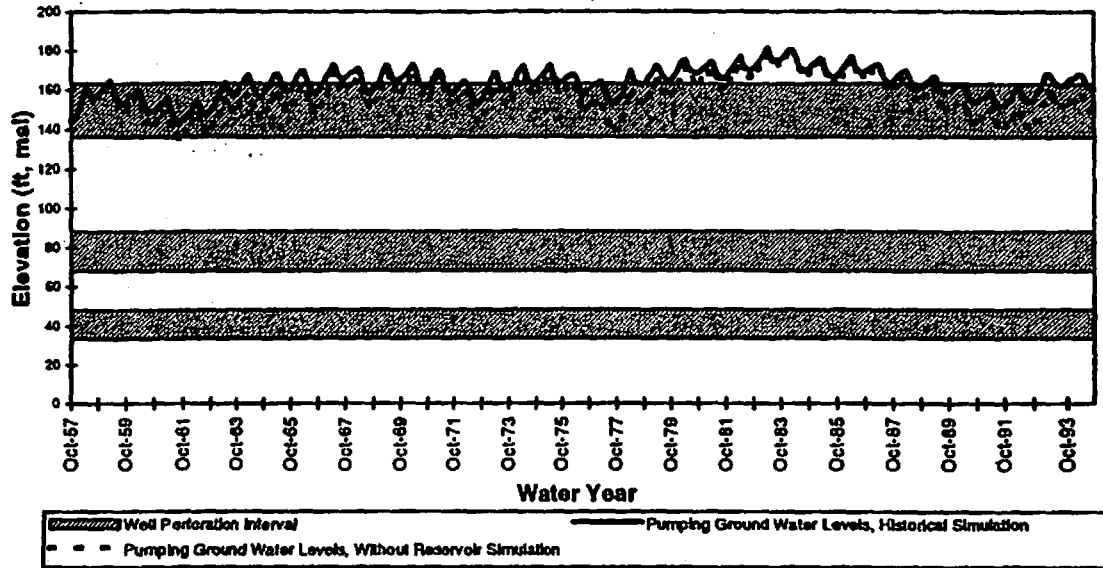

Figure 1-38

Well Perforations and Monthly Ground Water Levels
Well #14, Upper Valley Subarea

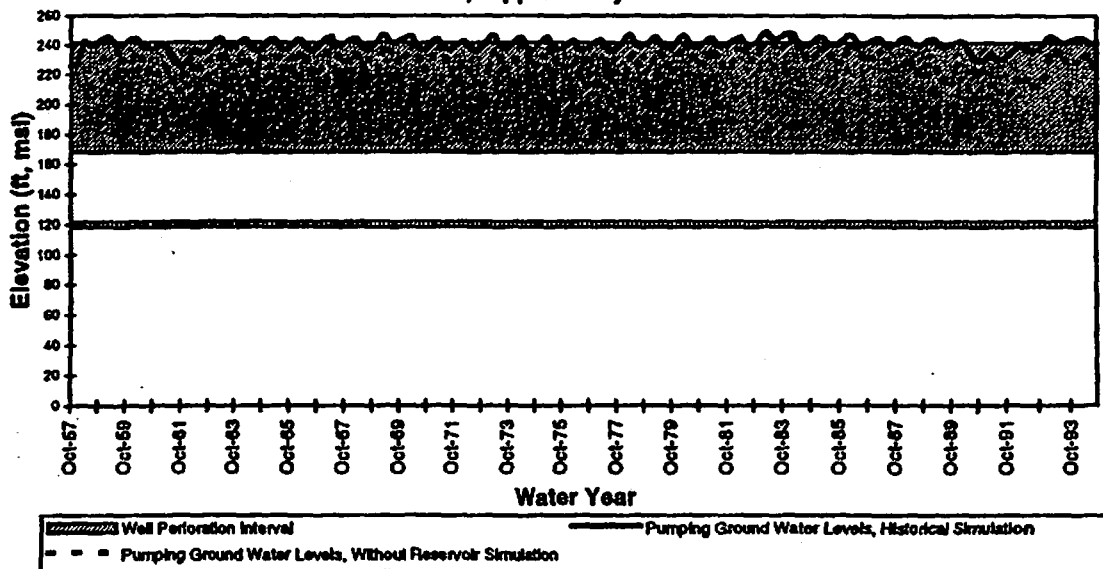

Figure 1-39

Well Perforations and Monthly Ground Water Levels
Well #15, Upper Valley Subarea

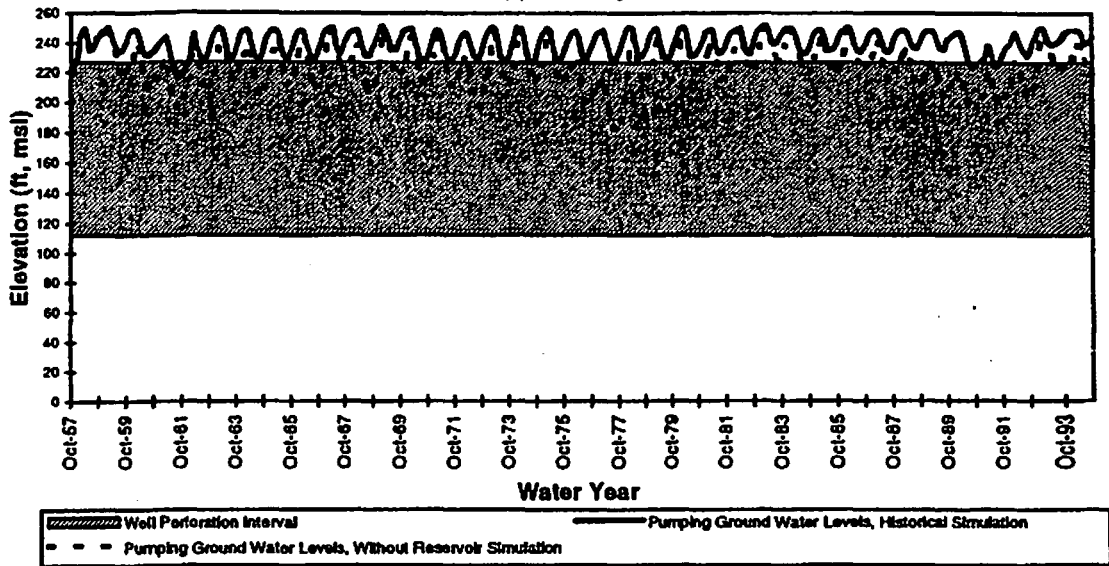

Figure 1-40

Well Perforations and Monthly Ground Water Levels
Well #16, Upper Valley Subarea

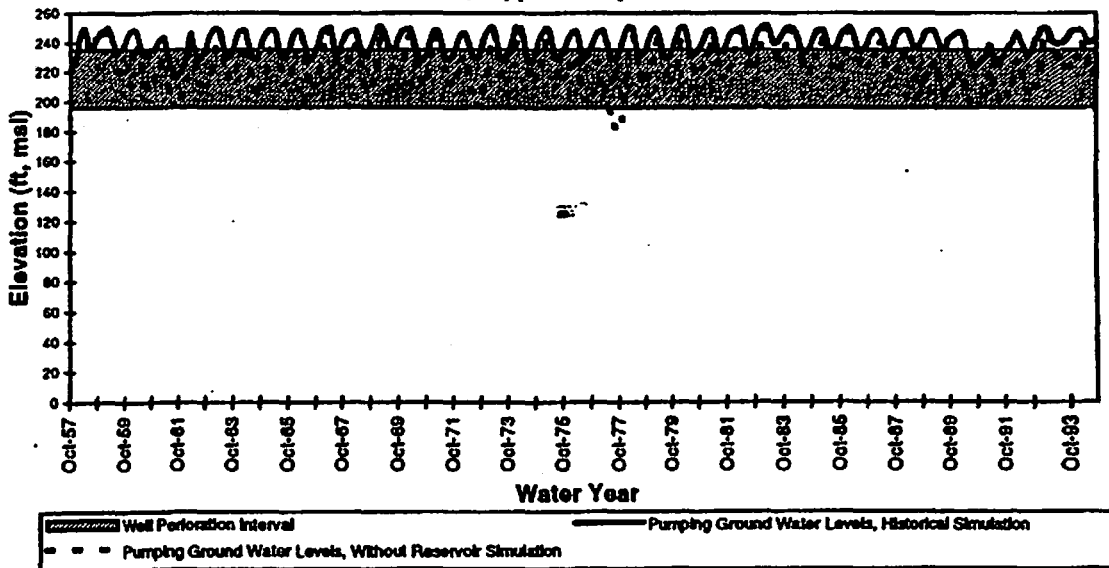

Figure 1-41

Well Perforations and Monthly Ground Water Levels
Well #17, Upper Valley Subarea

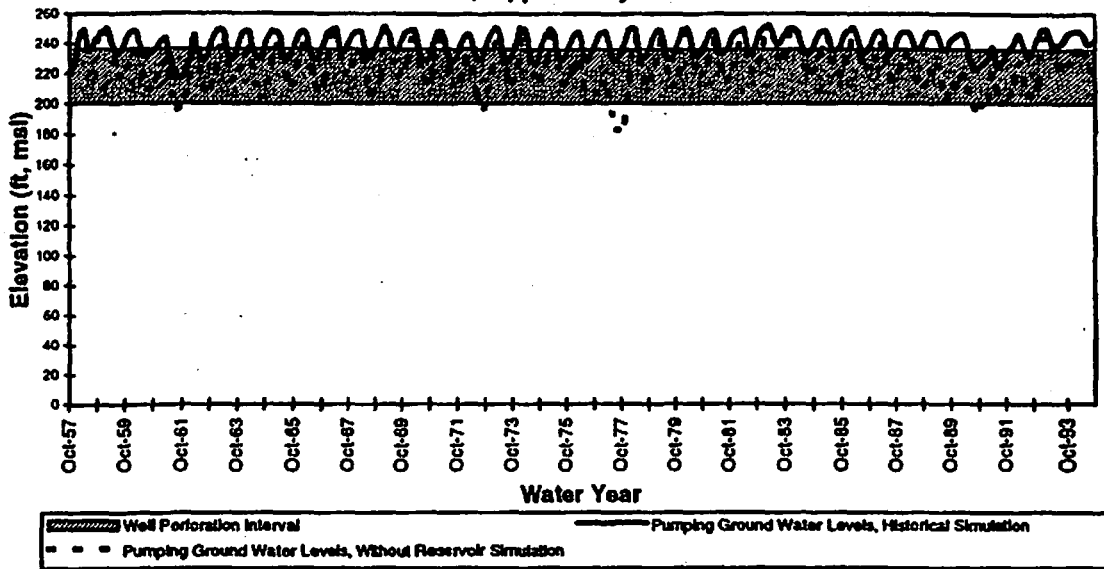

Figure 1-42

Well Perforations and Monthly Ground Water Levels
Well #18, Upper Valley Subarea

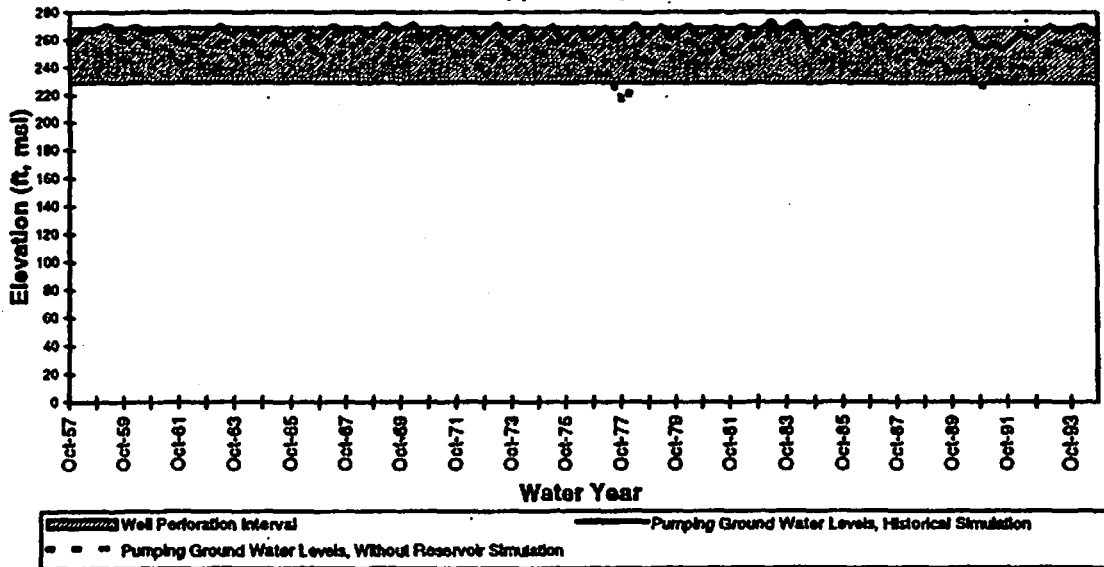

Figure 1-43

Well Perforations and Monthly Ground Water Levels
Well #19, Upper Valley Subarea

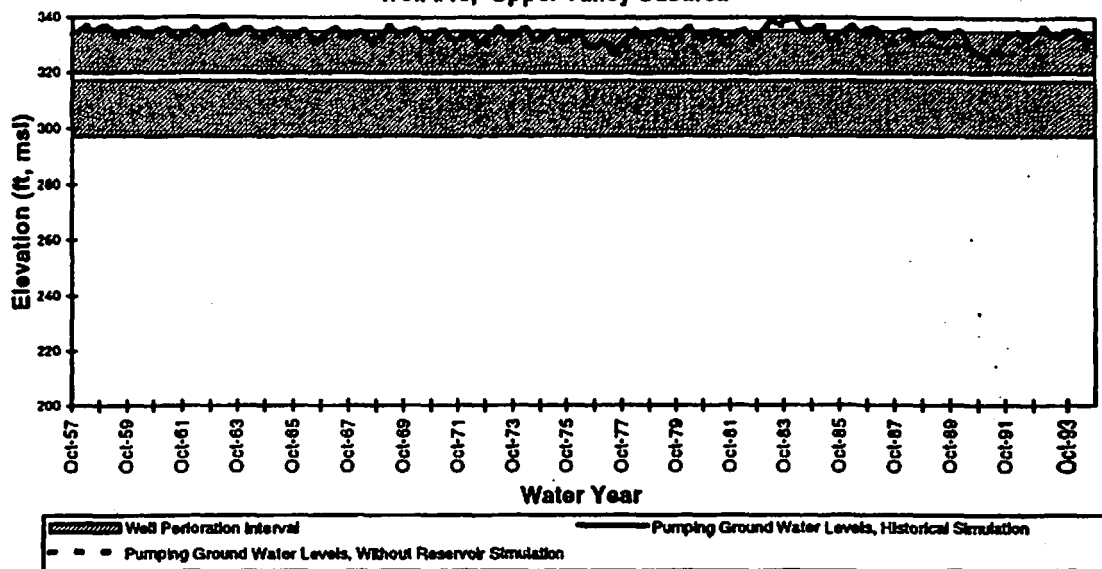

Figure 1-44

Annual Seawater Intrusion Rate Into the Pressure Subarea
(Simulated Flow Across the Coastline)

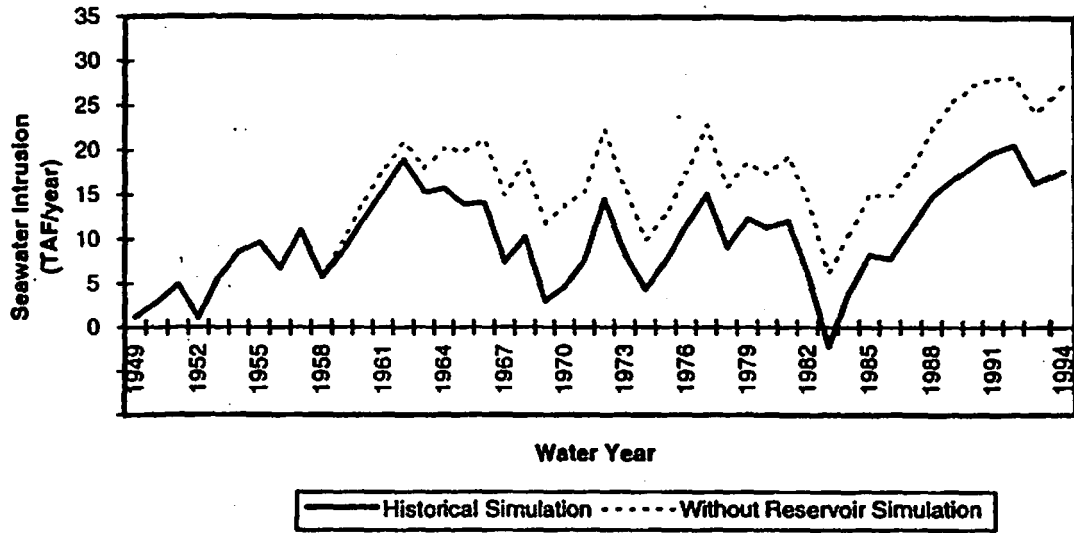
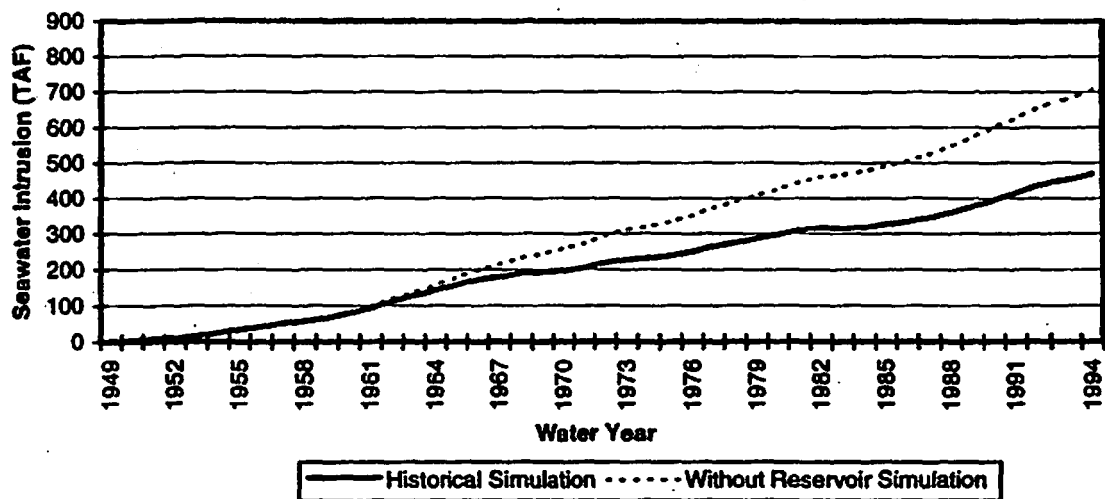

Figure 1-45

Cumulative Total Volume of Seawater Intrusion Into the Pressure Subarea
(Simulated Flow Across the Coastline)



Section 1 - Hydrologic Benefits Analysis

**Table 1-4
Summary of Detailed Well Performance Analysis**

| Well # | Performance Impact/ Modification Required | Impact Level |
|--------|----------------------------------------------|-----------------|
| 1 | Bowl Lowering Required | 2 |
| 2 | Minimal Performance Impact | 1 |
| 3 | Bowl Lowering Required | 2 |
| 4 | Bowl Lowering Required | 2 |
| 5 | Bowl Lowering Required | 2 |
| 6 | Minimal Performance Impact | 1 |
| 7 | Minimal Performance Impact | 1 |
| 8 | Minimal Performance Impact | 1 |
| 9 | Minimal Performance Impact | 1 |
| 10 | Minimal Performance Impact | 1 |
| 11 | Minimal Performance Impact | 1 |
| 12 | Minimal Performance Impact | 1 |
| 13 | Minimal Performance Impact | 1 |
| 14 | Additional Well Required | 3 |
| 15 | Minimal Performance Impact | 1 |
| 16 | Additional Well Required | 3 |
| 17 | Additional Well Required | 3 |
| 18 | Additional Well Required | 3 |
| 19 | Minimal Performance Impact | 1 |

Seawater Intrusion Impacts

The Pressure Subarea in the northern portion of the Salinas Valley borders the Monterey Bay. Extensive pumping and minimal recharge has resulted in a condition which has reversed the hydraulic gradient, allowing saline ground water flows from Monterey Bay into the Pressure Subarea aquifer. Over the years there has been a net flux of seawater into the Pressure Subarea. When compared to other subareas of the Salinas Valley, the extent of pumping is similar in the Pressure Subarea. But because aquifers are confined by clays in the coastal Pressure Subarea, recharge from inland areas must travel a great distance with the aquifers acting as conduits. The rate at

which recharge can flow through the aquifers is less than the rate extracted by irrigation wells. The result is lowered water levels or pressure head, allowing the seawater intrusion to move inland.

Monitoring of water quality throughout the area and in each of the aquifer layers has shown that the geographical extent of the intrusion front has moved inland. The result has been that wells that once produced high-quality ground water are now unable to produce water of useable quality. These wells must be abandoned and replacement wells must be drilled deeper to produce water of adequate quality. As the following analysis shows, the historical operations

**Table 1-5
Summary of Well Performance Impact Analysis**

| | Pressure Subarea | East Side Subarea | Forebay Subarea | Upper Valley Subarea | | | | |
|---------------------------------------------|-----------------------|--------------------------|-----------------------|--------------------------|-----------------------|--------------------------|-----------------------|--------------------------|
| Number of Wells in Sample Well Group | 185 | 84 | 65 | 50 | | | | |
| Wells with Hydrologic Impacts | 4 | 5 | 4 | 6 | | | | |
| Percent of Sample | 2.2% | 6.0% | 6.2% | 12.0% | | | | |
| Wells with Performance Impacts | 3 | 1 | 0 | 4 | | | | |
| Percent of Sample | 1.6% | 1.2% | 0.0% | 8.0% | | | | |
| Type of Performance Impact | Modification Required | Additional Well Required | Modification Required | Additional Well Required | Modification Required | Additional Well Required | Modification Required | Additional Well Required |
| Number of Wells | 3 | 0 | 1 | 0 | 0 | 0 | 0 | 4 |
| Percent of Sample | 1.6% | 0.0% | 1.2% | 0.0% | 0.0% | 0.0% | 0.0% | 8.0% |

Section 1 - Hydrologic Benefits Analysis

of Nacimiento and San Antonio Reservoirs have helped to reduce the volume and geographical extent of seawater intrusion into the Pressure Subarea. The economic impacts of reduced seawater intrusion will be analyzed in Section 3.

The SVIGSM can be used to quantify seawater intrusion impacts in two ways, on a volume of intrusion basis and on a geographical extent basis. The volume of seawater intrusion is measured as the net volume of subsurface flux that crosses the coastline. Figure 1-44 shows the simulated annual rate of seawater intrusion into the Pressure Subarea for all three aquifer layers. The values shown are the net fluxes across the coastline over the year. Annual intrusion rates vary according to hydrology, increasing during dry years, such as in 1987 to 1992, and decreasing during wet years, such as in 1983.

Beginning in 1958, the first year of reservoir operations, seawater intrusion rates are higher under the "without reservoir" conditions than under historical conditions. With the operations of Nacimiento and San Antonio, releases can be made to provide recharge along the Salinas River during the irrigation season, reducing the hydraulic gradient and the rate of seawater intrusion. Figure 1-45 shows the simulated cumulative seawater intrusion since 1949 for the historical and "without reservoir" conditions. Because the plot shows cumulative seawater intrusion since 1949 only, it begins at zero; it does not account for cumulative seawater intrusion prior to 1949. Again, the cumulative seawater intrusion is greater under "without reservoir" conditions. Overall, the difference in cumulative

seawater intrusion for the 1958-1994 period is approximately 240 TAF.

The geographical extent of seawater intrusion can be characterized by the location of the 500 parts per million (ppm) chloride concentration contour. The 500 ppm chloride concentration contours as estimated by the SVIGSM for aquifer layer 1 (Pressure 180-foot Aquifer) and layer 2 (Pressure 400-foot Aquifer) for September 1994 are shown in Figures 1-46a and 1-46b. These figures represent the extent of seawater intrusion at the end of the simulation period for both historical and "without reservoir" conditions. In the Pressure 180-foot Aquifer, the front of seawater intrusion is several miles farther inland under the "without reservoir" conditions. Although the front is also farther inland under "without reservoir" conditions in the Pressure 400-foot Aquifer, the difference is not as great. These differences in the extent of seawater intrusion are as expected in light of the greater volume of seawater intrusion observed under "without reservoir" conditions as described above.

In Figure 1-46a, the area between the contour lines representing historical and "without reservoir" conditions is the additional area impacted as a result of removing reservoir operations. Without the reservoirs in place, the wells which serve the agricultural area between the contour lines would have been abandoned and new wells would have been drilled to a deeper depth to produce water with acceptable quality. The same is also true of the area between the contours in the Pressure 400-foot Aquifer shown in Figure 1-46b. The irrigated acreage between the contours in the Pressure 180-foot

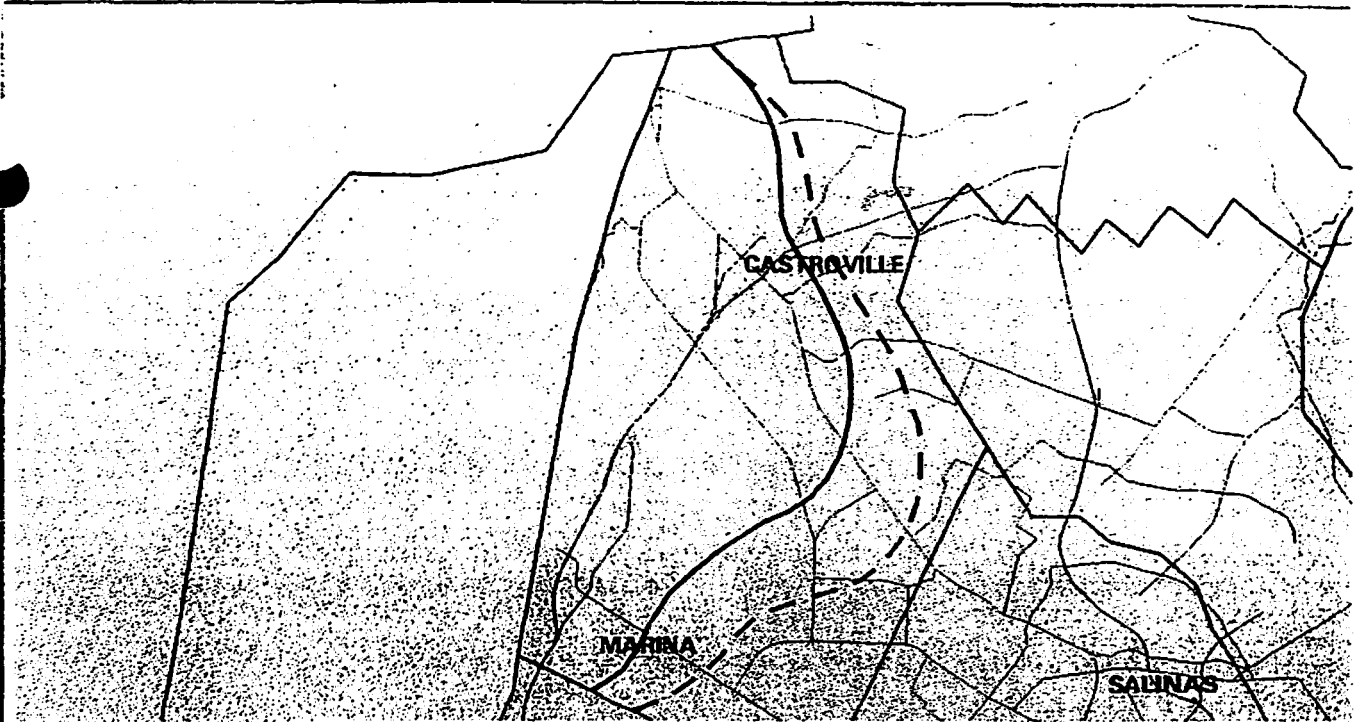

Figure 1-46a. 500 ppm Chloride Contour, 180-Foot Aquifer, Historical and Without Reservoir Simulation. September 1994

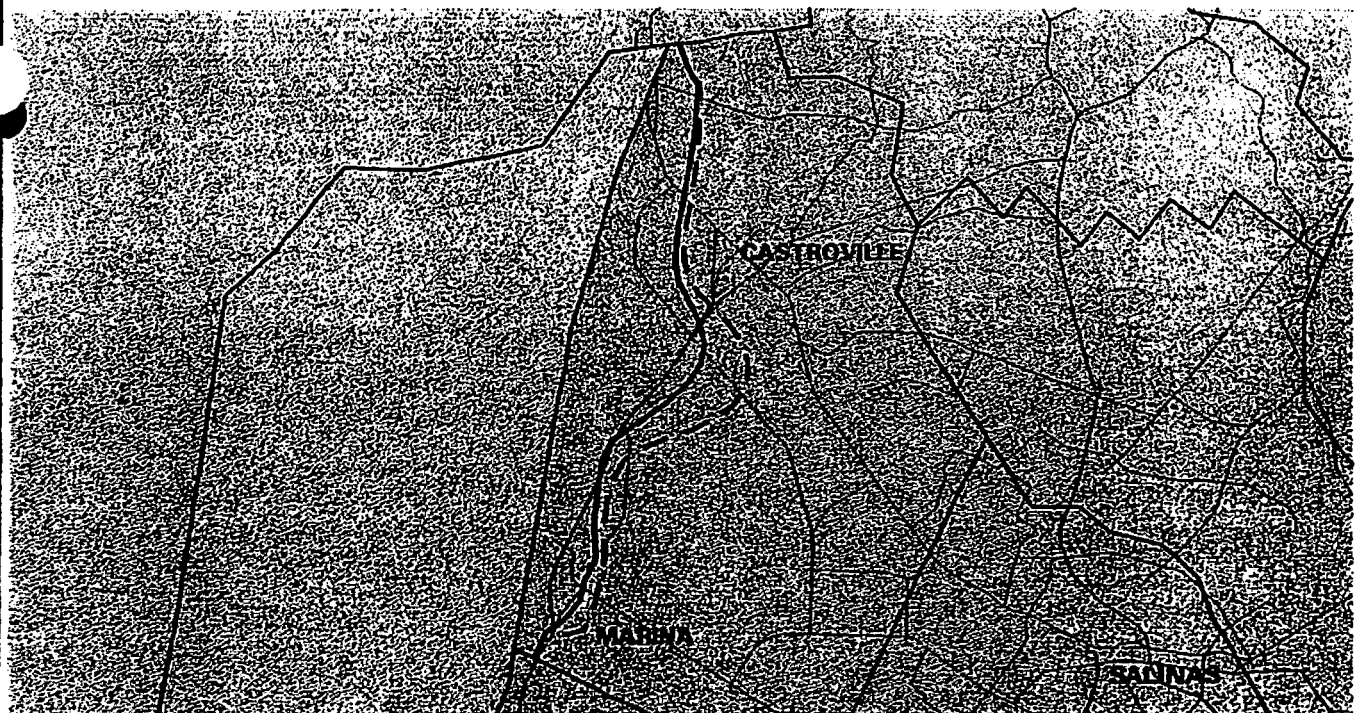

Figure 1-46b. 500 ppm Chloride Contour, 400-Foot Aquifer, Historical and Without Reservoir Simulation. September 1994

LEGEND

- Historical Simulation
- Without Reservoirs Simulation
- ESU Boundaries
- Roads
- Cities
- Monterey County
- Water Bodies

Salinas Valley Historical Benefits Analysis



1 0 1 2 3 4 5



MILES

AR 07084



**Monterey County
Water Resources Agency**

Source: SVIGSM, 1998

Note: This map and compilation of all information herein are approximate and are not to be used as a guide for design or conveyance work.

Section 1 - Hydrologic Benefits Analysis

Aquifer is 4,917 acres, and that between the contours in the Pressure 400-foot Aquifer is 1,211 acres. The avoided economic costs associated with drilling new wells to serve these acreages are estimated in Section 3.

Regional Ground Water Quality

The potential impacts of the operations of Nacimiento and San Antonio Reservoirs on ground water quality parameters not related to seawater intrusion, such as TDS, were examined for the Upper Valley Subarea. Water quality was examined in the Upper Valley Subarea because of concerns raised during the HBA workshop process that reservoir operations may have impacted ground water quality in that subarea. Areas within the Upper Valley Subarea east of the Salinas River are affected by water quality problems which stem from natural recharge of very poor quality coming from the eastern foothills of Gabilan and Diablo Ranges. The water is generally highly alkaline with high levels of TDS, ranging from 2,000 to 4,000 milligrams per liter (mg/L). Because a ground water quality model for simulation of TDS has not yet been developed for the Salinas Valley, available historical monitoring data and simulated ground water levels were used to examine the potential for impacts.

Historical ground water quality data were available for 39 monitoring wells in the Upper Valley. The water quality data at these wells were analyzed to examine the sensitivity of the water quality in these wells to flows in the Salinas River. Figure 1-47 shows the locations of the monitoring wells. Sampling data for many of the wells began in the mid-1950s, with measurements taken annually, usually

in mid summer to late summer. The monitoring data were analyzed based on location in the Valley, proximity to the Salinas River, and trends over time.

Figures 1-48 and 1-49 show plots of the monitoring data over time for two distinct groups of wells. They show the historical water quality for each well in the form of electroconductivity (EC) in micro-mhos ($\mu\text{mhos/cm}$). The series numbers in the legend correspond to the well numbers in Figure 1-47. In general, the wells plotted in Figures 1-48(a-c) have water quality ranging from several hundred $\mu\text{mhos/cm}$ to 1,500 $\mu\text{mhos/cm}$. Also, the water quality at these wells has remained fairly constant over time. The water quality for the wells shown in Figures 1-49(a-b), however, ranges from approximately 500 $\mu\text{mhos/cm}$ up to 4,500 $\mu\text{mhos/cm}$, and shows an increasing trend over time.

In general, based on a comparison between the water quality at each well and its location in the Valley, it appears that the water quality on the eastern side of the Salinas Valley is relatively poorer and exhibits an increasing trend in EC over time. In some cases, proximity of the well to the Salinas River appears to enhance and maintain the ground water quality over time. This effect may be attributable to recharge from the Salinas River. An attempt was made to correlate the water quality in the wells with flows in Salinas river. However, partly because of the limited sampling frequency (only yearly data was available), no significant correlation was observed.

Additional analysis was made to evaluate the impact of the operations of the reservoirs on the rate of movement

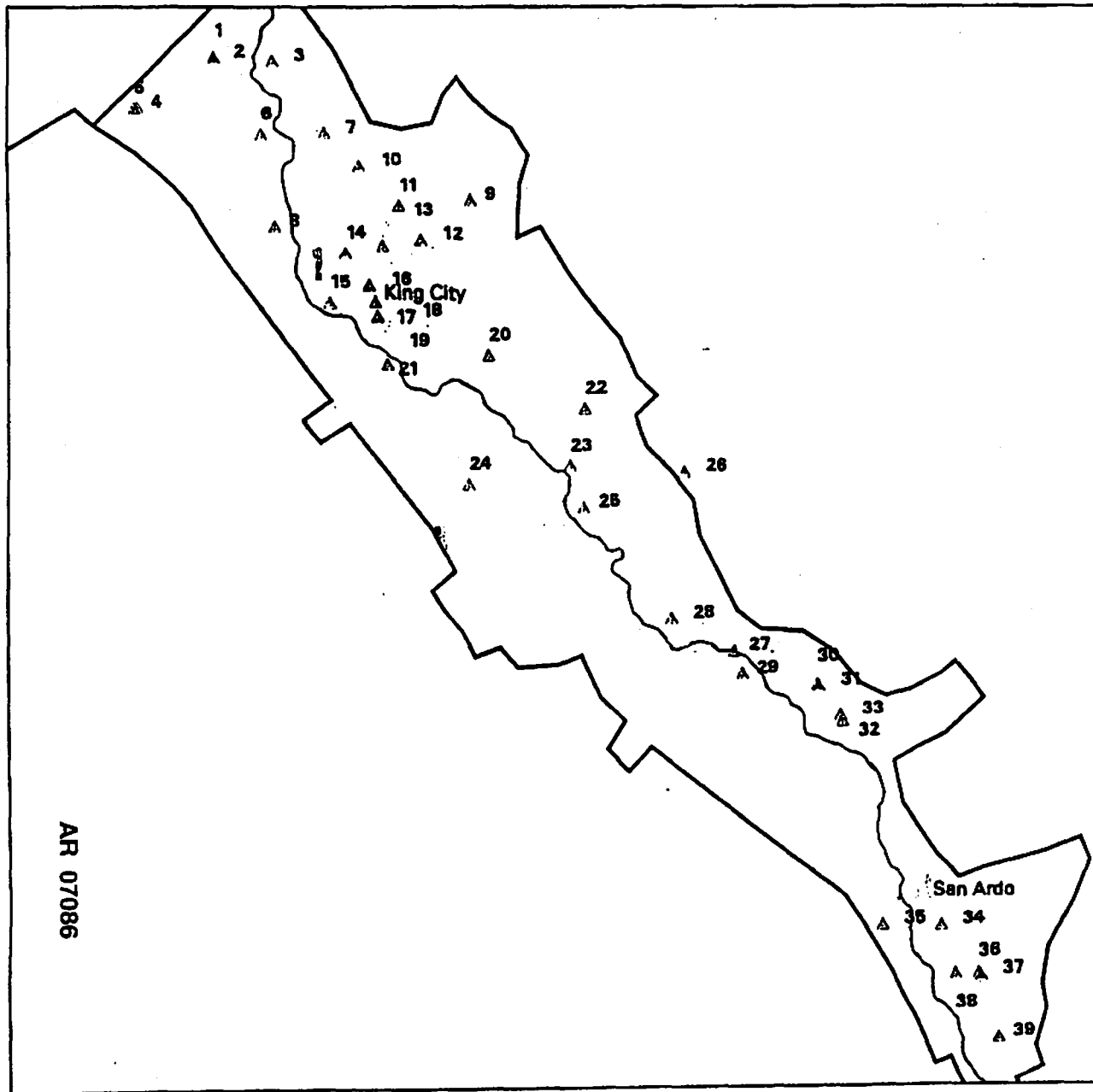

ARR 07086

Figure 1-47
Salinas Valley Historical
Benefits Analysis
Location of Upper Valley Wells Used
For Water Quality Analysis

LEGEND

- ▲ Monitoring Well
- Cities
- Subarea Boundaries
- ∩ Rivers

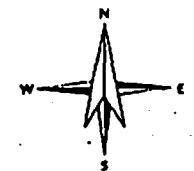

Monterey County
Water Resources Agency

Source: MCWRA

Note: The scale and configuration of all information shown herein are approximate and are not intended as a guide for design or survey work.

Figure 1-48a

Upper Valley Subarea Ground Water Quality Monitoring Data
Monitoring Wells with Higher Quality Water

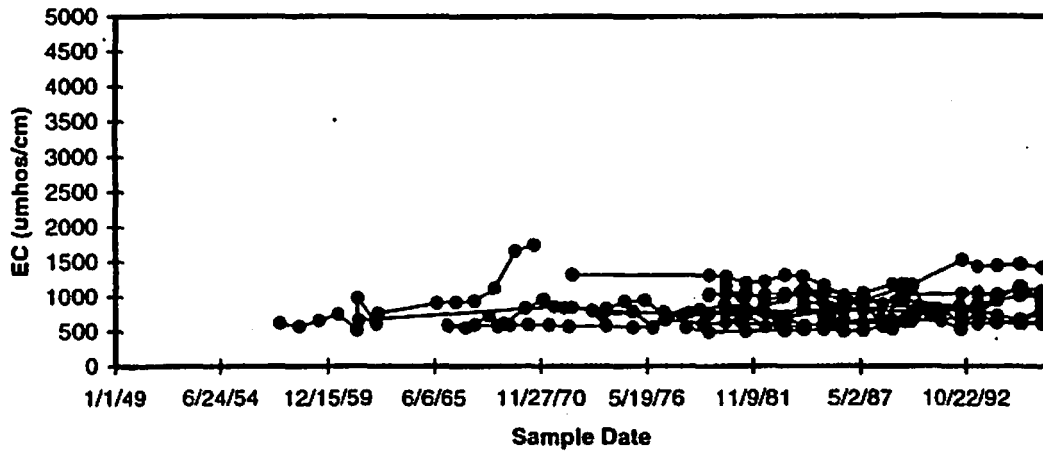

Note: Series numbers correspond to well numbers on Figure 1-45

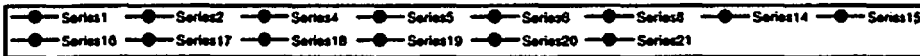
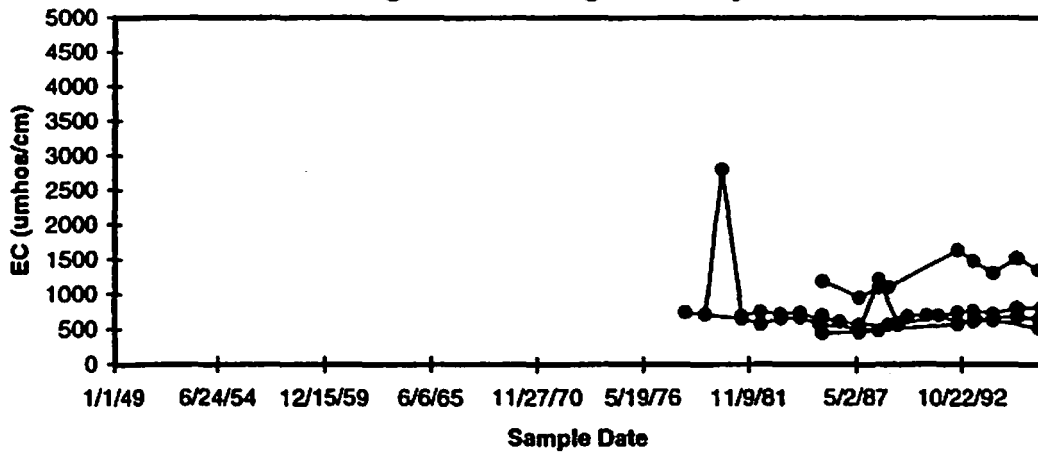

Figure 1-48b

Upper Valley Subarea Ground Water Quality Monitoring Data
Monitoring Wells with Higher Quality Water



Note: Series numbers correspond to well numbers on Figure 1-45



Figure 1-48c

Upper Valley Subarea Ground Water Quality Monitoring Data
Monitoring Wells with Higher Quality Water

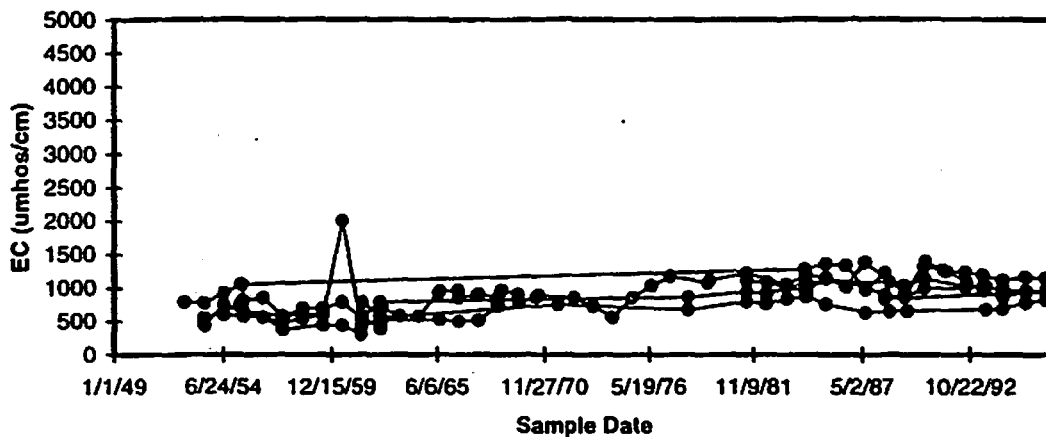

Note: Series numbers correspond to well numbers on Figure 1-45

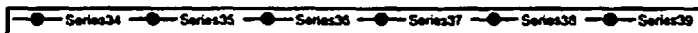
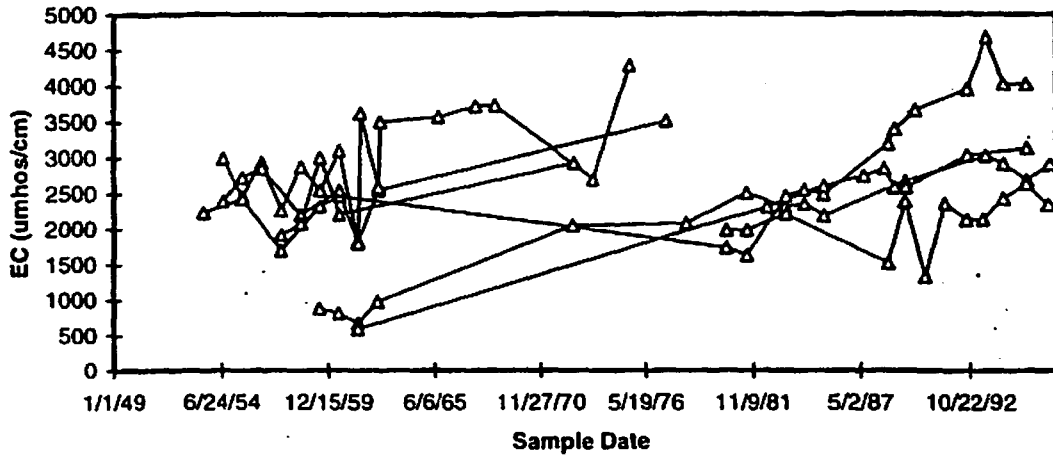

Figure 1-49a

Upper Valley Subarea Ground Water Quality Monitoring Well Data
Monitoring Wells with Lower Quality Water



Note: Series numbers correspond to well numbers on Figure 1-45



Figure 1-49b

Upper Valley Subarea Ground Water Quality Monitoring Well Data
Monitoring Wells with Lower Quality Water

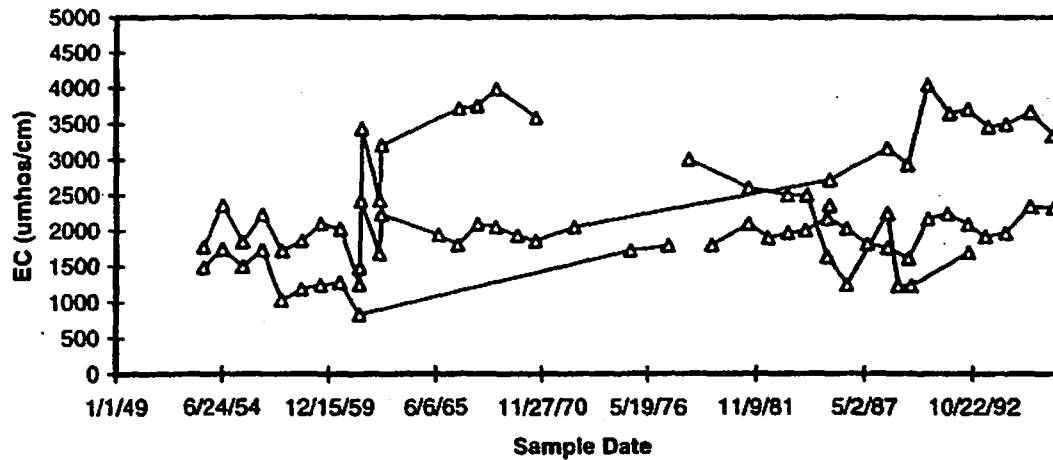

Note: Series numbers correspond to well numbers on Figure 1-45



Section 1 - Hydrologic Benefits Analysis

of ground water towards the river. The main assumption in this analysis is that if the flow rates towards the Salinas River increase significantly, under the "without reservoir" conditions compared to the historical case, there will be potential for movement of poor quality water towards the river, where most of the production wells are located.

To accomplish this task, of the 39 wells that are used for water quality monitoring, 15 wells that had well construction information were selected. Ground water level contours and regional hydraulic conductivities at wells 11, 13-15, 18, 20, 23, 25, 28, 30, 31, and 33-36 (Figure 1-47) were used to estimate regional ground water flow rates based on Darcy's Law. Darcy's Law defines the ground water flow rate as the product of aquifer hydraulic conductivity and gradient of ground water. Based on this approach, ground water flow rates for three hydrologic conditions, average, above normal, and below normal were estimated for both the historical and the "without reservoirs" cases.

Table 1-6 shows a comparison of the average flow rates for each period under both scenarios. For both the average and below normal hydrologic conditions, it appears that the ground water velocities increase slightly (10 to 15 percent) under the "without reservoirs" condition, indicating potentially faster movement of poor ground water quality. In above normal conditions, however, the velocity is smaller (approximately 2 percent) under "without reservoirs" conditions.

The estimated rates of ground water flow shown in Table 1-6 are in low range of typical velocity rates for ground water. To get an idea of the time required for the ground water to move from the foothills to the vicinity of the river, a distance of 1-2 miles, assume an average velocity rate of 0.4 Ft/Day. The time requirement would be approximately 35 to 70 years.

Given the small differences in velocities between the historical and the "without reservoir" conditions, the time span required for the ground water to migrate to the vicinity of the river, and the limited water quality data, concrete and substantive conclusions cannot be drawn on the impacts of reservoir operation.

Additional data collection and monitoring is required to evaluate the nature and source of poor quality water. In addition, analysis of aging of the ground water and tracer testing will be helpful in identifying the contributions of the foothill recharge to the ground water in the vicinity of the river, as well as the contributions of river flows to the ground water.

HYDROLOGIC IMPACTS UNDER BASELINE CONDITIONS Baseline Analysis

The objective of the baseline conditions analysis is to determine the hydrologic impact of the operations of Nacimiento and San Antonio Reservoirs under current land use and water use conditions. The analysis is identical to that used to determine impacts under historical conditions; hydrologic conditions "with" and "without reservoirs" are compared to determine the changes that occur as a result of reservoir operations.

Section 1 - Hydrologic Benefits Analysis

**Table 1-6
Ground Water Flow Velocities in the Upper Valley**

| Hydrologic Condition | Ground Water Flow Velocity (Ft/Day) | |
|----------------------|----------------------------------------|------------------------------------|
| | Historical Conditions | "Without Reservoirs" Conditions |
| Average | 0.37 | 0.41 |
| Above Normal | 0.42 | 0.41 |
| Below Normal | 0.40 | 0.46 |

The baseline analysis reflects the benefits directly associated with the operations of the reservoirs, without the effect of changes in land use and development over time. Although no economic benefits analysis will be performed on baseline conditions, the hydrologic analysis provides additional insight into the benefits of reservoir operations.

Unlike the historical simulations used for the HBA, where land and water use changes take place over the simulation period, the baseline simulations use a constant level of development throughout the simulation period. Current, or 1995, land use and water use conditions are used for the entire 1949-1994 simulation period. This analysis shows the benefits that would accrue as a result of reservoir operations if today's level of development continued into the future under 1949-1994 hydrologic conditions. It is assumed that climatic conditions over the 1949-1994 period are representative of future hydrology. Because the baseline analysis uses a constant level of development, there is no ramping up of impacts, and the changing component of land and water use are removed.

Because the simulation years in a baseline simulation do not reflect actual historic conditions, the hydrologic year (1949-1994) are not used to represent the simulation period. Instead, "simulation years" are used in the plots for baseline conditions. The 1949-1994 simulation period for the baseline simulation is expressed as simulation years 1 through 46. The hydrology used for simulation year 1 is the same as that for water year 1949, and that for simulation year 2 is water year 1950 hydrology, etc.

Ground Water Levels

Figure 1-50 shows the contours of increases in ground water levels as a result of the operations of Nacimiento and San Antonio Reservoirs. These contours indicate the potential increases in ground water levels that would result, should present water use conditions continue into the future, and the 1958-94 hydrologic period repeat.

As Figure 1-50 shows, increases in ground water levels in the Pressure and East Side Subareas range from 5 feet near the coast, to 40 feet toward the southern portions of these subareas. Ground water levels in the northern half of the Forebay Subarea increase from 10 to 30 feet, while remaining in the 5-foot to 10-foot range in the

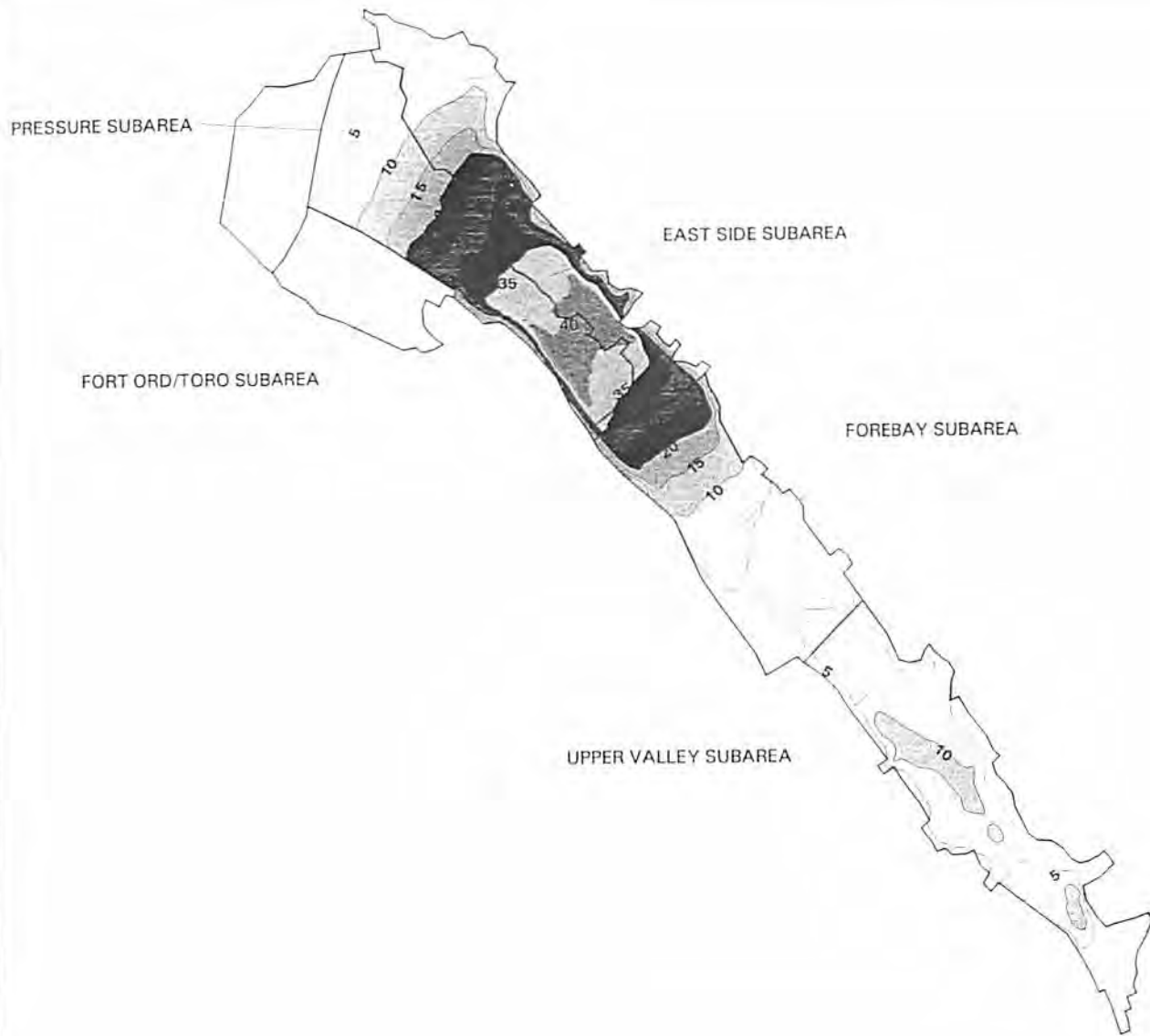

Figure 1-50
Salinas Valley Historical Benefits Analysis
 Average Increase In Ground Water Levels, With vs. Without Reservoirs, Baseline Conditions (1958-1994)

LEGEND

- Subarea Boundaries
- Ground Water Difference Contours
- 0.0 to 4.9 ft
- 5.0 to 9.9 ft
- 10.0 to 14.9 ft
- 15.0 to 19.9 ft
- 20.0 to 24.9 ft
- 25.0 to 29.9 ft
- 30.0 to 34.9 ft
- 35.0 to 39.9 ft
- 40.0 to 44.9 ft



Monterey County
 Water Resources Agency

Source: SVIGSM, 1998

Note: The scale and configuration of all information shown hereon are approximate and are not intended as a guide for design or survey work.

Section 1 - Hydrologic Benefits Analysis

southern half of the subarea. Most areas in the Upper Valley Subarea show increases in ground water levels ranging from 5 to 15 feet.

simulations for the 37 years of simulation is 320 TAF, approximately 80 TAF more than the historical simulations.

The same mechanisms which cause increased ground water levels in the historical simulations are in effect in the baseline simulations. Operations of the reservoirs allow better utilization of Salinas River flows for recharge purposes. Releases during the irrigation season take advantage of the higher recharge potential during those months and maintain the ground water at higher levels. The cumulative difference in stream recharge for the "with" and "without reservoir" simulations is shown in Figure 1-51. Over the 37 years of simulation, the operation of the reservoirs adds approximately 720 TAF of fresh water to the ground water basin.

Seawater Intrusion

The annual seawater intrusion measured as flux across the coastline is shown for the "with" and "without reservoir" baseline simulations in Figure 1-52. As in the historical simulations, the volume of seawater intrusion is greater in the "without reservoir" simulation. When compared with Figure 1-44, the difference in intrusion rates is greater for baseline simulations than for historical simulations because the higher level of development (1995 conditions) is sustained for the entire simulation period. Figure 1-53 shows the cumulative total volume of seawater intrusion since beginning of simulation. The same corresponding hydrologic period is used to be comparable to Figure 1-47. The cumulative difference in seawater intrusion between the "with" and "without reservoir"

Figure 1-51

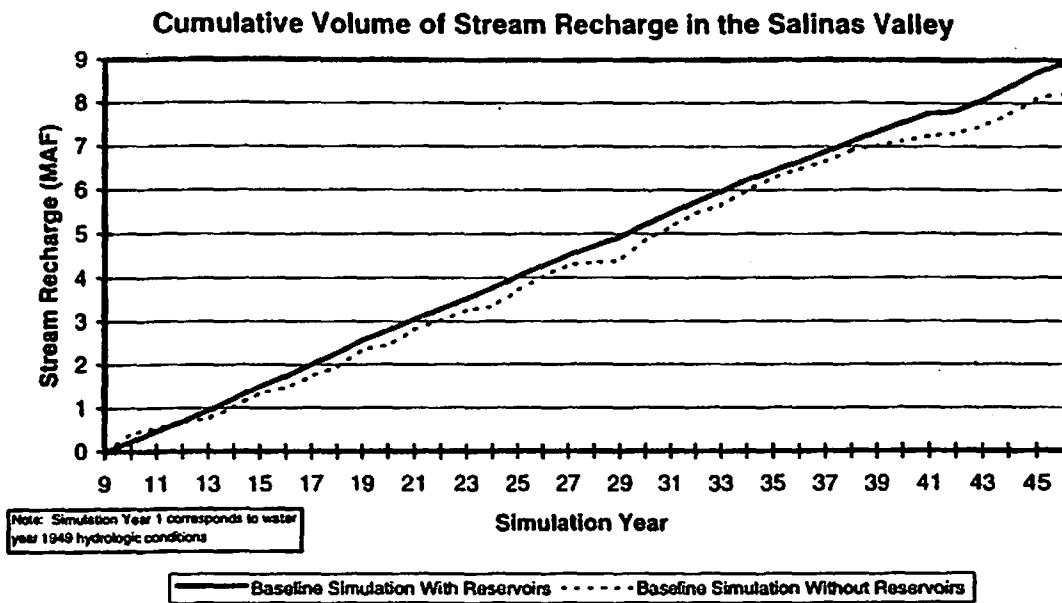

Figure 1-52

Annual Seawater Intrusion Rate Into the Pressure Subarea
(Simulated Flow Across the Coastline)

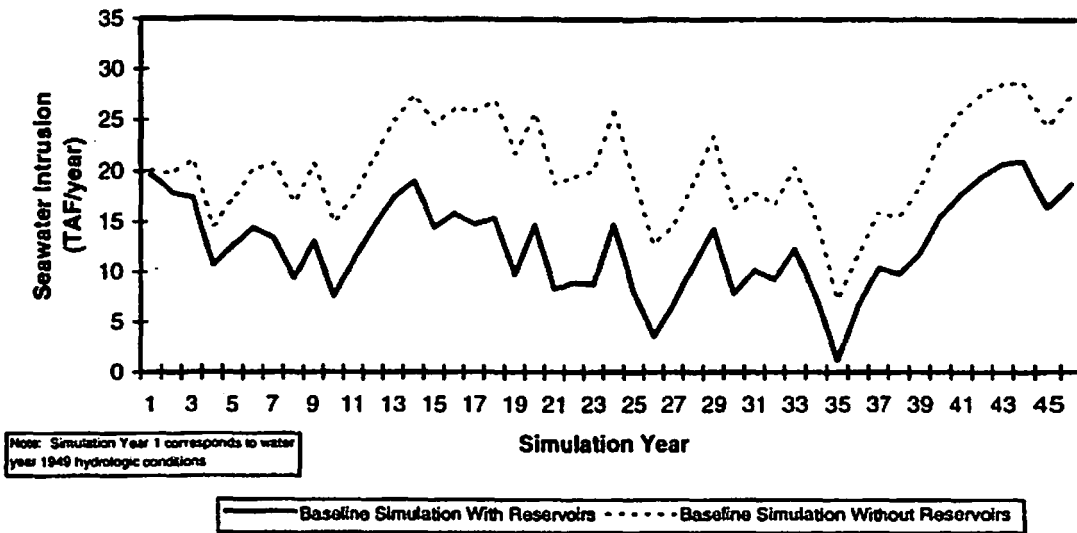
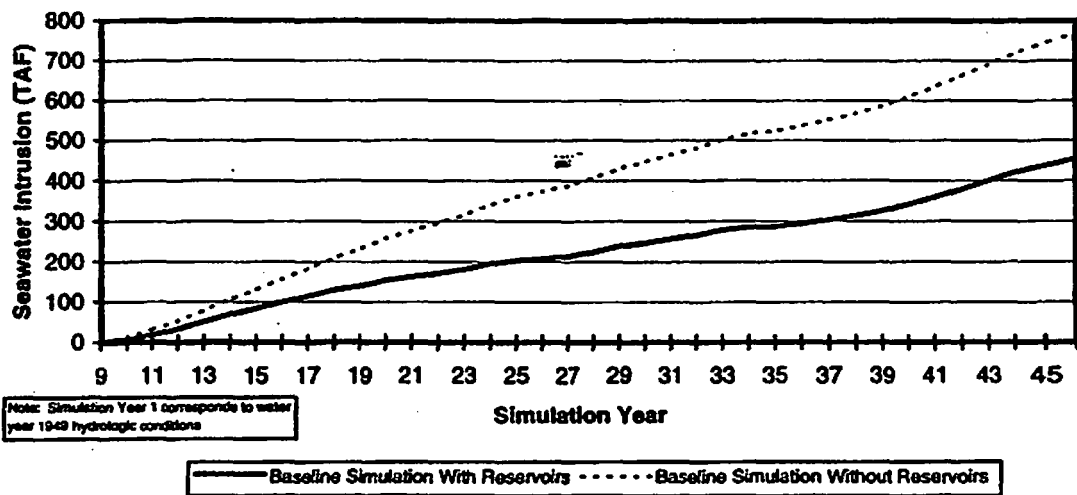

Figure 1-53

Cumulative Total Volume of Seawater Intrusion Into the Pressure Subarea
(Simulated Flow Across the Coastline)





Section 2



MONTGOMERY WATSON

AR 07096

Section 2

Flood Control Benefits Analysis

BACKGROUND

The analysis of flood control benefits was undertaken by the Monterey County Water Resources Agency (MCWRA) as a portion of the Historical Benefits Analysis to provide a complete picture of the benefits afforded through construction of Nacimiento and San Antonio Reservoirs. Both reservoirs were constructed as multi-purpose reservoirs; that is, they provide additional water supply as well as flood control benefits.

River Reaches

The Salinas River courses approximately 105 miles from the Pacific Ocean to the confluence with the Nacimiento River. This is the total length over which any flood control benefits would apply. Upstream of the confluence with the Nacimiento River the flows on the Salinas River would remain largely unaffected by the operation of Nacimiento and San Antonio Dams. The only effect might be a slight change in the backwater conditions along a short reach of the Salinas River just upstream of the Nacimiento River. This could also be said about the various tributaries flowing into the Salinas River between Nacimiento/San Antonio Rivers and the Pacific Ocean. The flows on these tributaries would also be largely unaffected by the operations of the Nacimiento and San Antonio Dams, with only small changes in the flooding characteristics near the Salinas River floodplain. These changes to floodplains along the Salinas River upstream of Nacimiento River and along tributaries to the Salinas River were not considered in this study. The only changes considered are changes to the floodplain along the Salinas River itself from the confluence with the Nacimiento River to the Pacific Ocean.

For purposes of analysis, this long stretch of the Salinas River was broken into nine reaches. The nine reaches, with Reach 1 beginning at the Pacific Ocean and Reach 9 terminating at its confluence with the Nacimiento River, are:

Reach 1 - River Mile 0 to River Mile 18.7

Reach 2 - River Mile 18.7 to River Mile 30

Reach 3 - River Mile 30 to River Mile 40

Reach 4 - River Mile 40 to River Mile 50

Reach 5 - River Mile 50 to River Mile 60

Reach 6 - River Mile 60 to River Mile 70

Reach 7 - River Mile 70 to River Mile 80

Reach 8 - River Mile 80 to River Mile 88.8

Reach 9 - River Mile 88.8 to River Mile 105.8

Reach 1 covers the major portion of the Federal Emergency Management Agency (FEMA), 100-year floodplain under the "with reservoir" condition. Reach 9 lies beyond the extent of the MCWRA's current digital mapping.

Purpose

This study was necessary to provide certain information concerning physical, flood control hydrology and flood control hydraulics. This information was input to the economic analysis of flood control benefits. The information required for the economic analysis is the annual probability of exceedance of discharges along the river given either of the two flood control situations "with" and "without reservoirs", the

Section 2 - Flood Control Benefits Analysis

depth of flooding for a given discharge, and the potential for damage from erosion during flooding.

To analyze the overall benefits of the reservoirs, it was necessary to determine their flood control functions. This flood control benefit assessment analysis is statistical in nature and is not similar to the Hydrologic Benefit Analysis that was used for the water supply functions of the reservoirs. The average annual benefits analysis assumes a statistical distribution of floods, not the precise historical pattern that has occurred. Because flood discharges and floodplain areas are related and because floodplain areas and damage are related, the damages from flooding are measured in terms of statistical frequencies of flood events, not the actual sequence of floods and consequent flood damages that occurred in the river valley. Although the flooding that has occurred was considered in the analysis, the results are not solely based on actual occurrence of those sequences of floods.

This statistical approach was utilized for purposes of convenience, cost, and time. The alternative method of routing all historical floods through the Salinas River floodplain would require a significantly greater level of effort. Actual flood data from either the 1969 or 1995 floods were utilized whenever those data differed from the predicted floodplain information. (See "Hydraulics and Floodplain Mapping" Section for more information.)

Study Plan

This flood control benefits study consists of two components: 1) a study of the probability of flooding along the Salinas River under the "with reservoirs" and the "without reservoirs" conditions, and 2) a delineation of the flood-prone areas along the river for a variety of frequencies of flood

events. In addition to identifying the flood-prone areas, potential erosivity of the floodplain area was investigated to estimate potential damage from top soil erosion during floods and from the accumulation of silt at other areas during the same events.

The flood control hydrology study was done using available data and available models to predict probability curves which relate discharge to the probability of exceedance. A discharge value is reported in units of cubic feet per second (cfs). Exceedance probability is the percentage chance per year that a given discharge will be equaled or exceeded at any time during the year.

The hydraulics study was done using the U.S. Army Corps of Engineers (Corps) HEC-2 model, which predicts water surface elevations for given discharges, roughness values and cross-sectional information. For this study, the discharges came from the exceedance probability analyses produced during the flood control hydrology task; the roughness values came from calibrating to the high water marks set by the Corps during the 1969 floods; and the cross sections came from FEMA information and from MCWRA's 1000-foot-scale, 10-foot contour maps, which are part of its central Geographic Information System (GIS) system.

These three elements of the hydraulics study were combined, resulting in floodplain maps for the 100-year floods "with" and "without" reservoirs, and the 25-year flood with the reservoirs in place. These maps became the basis of the economic evaluation.

In addition to the three floodplains, an estimate of the capacity of the river channel in each of the nine reaches was also provided. This information is important to the economics analysis because it defines the

Section 2 - Flood Control Benefits Analysis

annual probability for little or no damage from flooding, because the flood waters are contained within the river channel itself. The area outside the river channel is known as the overbank area, and is the area where flood damage typically occurs.

The siltation/sedimentation study for the overbank areas was done using the results of the HEC-2 analysis which produced flow velocities in the overbank areas. This analysis also used the U.S. Department of Agriculture's Soil Conservation Service soil maps of Monterey County. Each soil type on those maps has a corresponding erosion index assigned to it. This erosion index relates to loss of top soil from sheet and rill erosion during the rainfall-runoff process. This information was extrapolated to act as an indicator of erosion potential for flood water running over the surface. Flood water erosion is generally much greater than the erosion from normal rainfall-runoff erosion. However, it was assumed that the soil map erosion indices provide a relative measure of soil erosion potential under flood conditions.

FLOOD CONTROL HYDROLOGY

The hydrologic procedures used in developing annual exceedance probability curves of flooding under the "with" and "without reservoirs" scenarios were based upon fitting curves through data points. The data points were plotted using a standard plotting position formula. The results are a series of annual exceedance probability curves for a variety of flow durations for the "with" and "without" conditions.

Flow Data

Three sources of data were used to determine the probability of flooding for the "with" and the "without reservoirs" scenarios. The first source of data was the

U.S. Geological Survey. The Survey's published data for two long-term stream gaging stations - Salinas River Near Bradley, and Salinas River Near Spreckels - provided good quality data for the upstream and downstream limits of the study area. These data consisted of peak discharges as well as daily average discharge values. The USGS has measured flows at the Spreckels gage since 1929 and at the Bradley gage since 1948.

The second source of data was the SVIGSM as developed for other aspects of this overall investigation into this Historical Benefits Analysis. These data consisted of average daily flows for the period of 1949 to 1994. The data was available at the Bradley and at the Spreckels gage locations. SVIGSM stream flows were available for both the simulated historical and "without reservoirs" conditions.

The third set of data was generated by a rainfall-runoff model originally developed by the US Army Corps of Engineers in the aftermath of the 1969 floods and subsequently used by FEMA when developing the flood insurance maps for Monterey County in the late 1970's. This data consisted of peak discharges and 24-hour average discharges for four or five points along the Salinas River from Bradley down to Spreckels. These data were only established for the 10-year flood, the 50-year flood and the 100-year flood.

Durations

Flow or discharge data are measured in cfs. Numerous different time periods are considered when assessing river flooding. The most important discharge is that of the instantaneous peak discharge, the largest discharge to be recorded in any water year regardless of its duration. After the instantaneous peak, the next important discharge is the maximum average one-day

Section 2 - Flood Control Benefits Analysis

flow, the maximum average flow for any one calendar day during a water year. The maximum average three-day discharge is the largest average flow during any consecutive three-day period during any water year. The final duration of discharge considered in this investigation is the five-day flow, which is the maximum average discharge recorded during any consecutive five-day period for any water year.

Discharges for all four durations under investigation (instantaneous, one-day, three-day and five-day) were carried into the statistical analysis for the "with" and "without reservoirs" conditions.

Statistical Analyses

The annual series of instantaneous peak discharge data from the two USGS stream gages along the Salinas River are shown in Figure 2-1. The data from the Spreckels gage date back to 1929, providing 27 years of pre-reservoir data. The Bradley gage data began in 1948, providing only eight years of pre-reservoir operations data. Both gages are still in operation. Unimpaired flows at Bradley from SVIGSM provided 47 years of record from water years 1948 to 1994.

The statistical analysis was performed by using the Median Plotting Position formula to plot the exceedance probability of each data point on log-normal plotting paper. Log-normal paper has a logarithmic axis in the y-direction for discharges and a normal distribution variant axis in the x-direction for exceedance probability. The discharges are always in units of cfs, while the probabilities are in units of percent probability (or chance) per year of being equaled or exceeded. The exceedance probability data points were plotted for each duration from instantaneous to five-day average discharge. All data were recorded on one sheet of paper for each

stream gage location for the "without reservoirs" condition, and on one sheet for the "with reservoirs" condition for each stream gage location.

The HEC-1 model results were then added to the resulting four plots (two gage locations, two reservoir conditions) of discharge versus exceedance probability. As noted these HEC-1 models were developed by the US Army Corps of Engineers in the aftermath of the 1969 floods. As such, the model was calibrated to replicate conditions during those floods. Since those floods, however, two major changes have occurred. First, MCWRA has changed the operational rule curves for the reservoirs after consideration and incorporation of both State of California dam safety criteria as well as FERC (Federal Energy Regulatory Commission) criteria for Nacimiento Dam.

Second, the unit hydrographs from the Nacimiento and San Antonio watersheds upstream of the two reservoirs were re-computed. MCWRA analyzed all of the latest available rainfall data in those two watersheds, and developed unit hydrographs for large flood events based on the inflow records to the reservoirs.

The unit hydrograph is a hydrologic concept used in rainfall-runoff models that represents how a given watershed discharges 1 inch of runoff that was generated by a storm that lasted some unit time. A typical unit hydrograph for a one-hour storm, for example, may show that at the outlet point of the watershed the one-inch of runoff begins very slowly, becomes greater and greater, reaches a peak discharge some time (maybe hours) after the one-hour rainfall has begun, and then falls off until some time (maybe hours) later the flow essentially ceases. If the discharge from that watershed is measured over the time of flow, the volume of water flowing

Figure 2-1

Annual Peak Discharges at Selected Long-Term
U.S. Geological Survey Gaging Stations

SALINAS RIVER AT SPRECKELS

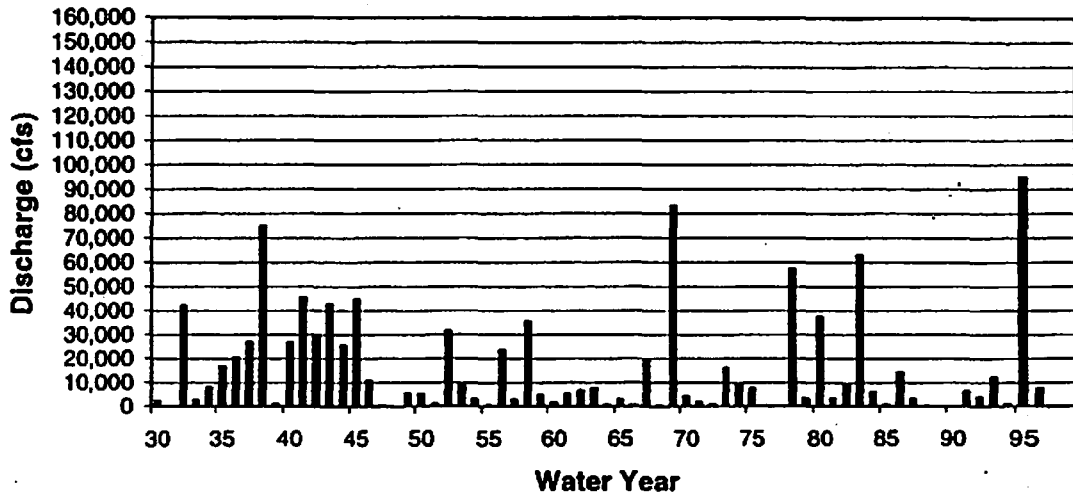

SALINAS RIVER AT BRADLEY

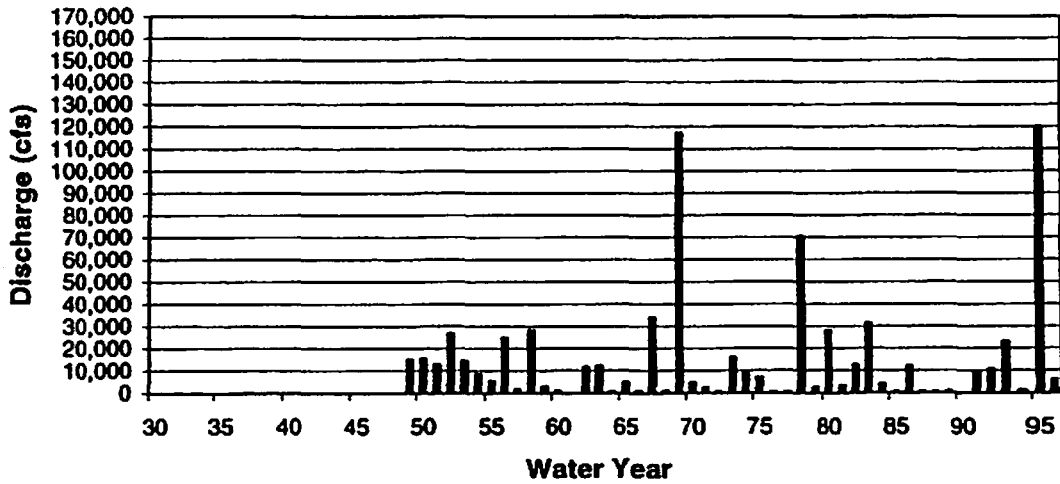

Section 2 - Flood Control Benefits Analysis

past the gage point would be equal to 1 inch of water over the entire watershed area.

Incorporation of these two modifications were made and the HEC-1 model was run for the 10-year flood, the 50-year flood, and the 100-year flood for both the "with" and "without reservoirs" conditions. The results were used to help specify the exceedance probability curves at the upper ends (the low probability areas; the rarer, more severe flood events). Only discharges for two durations were predicted by the model: instantaneous peak discharge and one-day average discharge. The hypothetical storms used in the HEC-1 model were too short to adequately assess the three-day and five-day average discharges.

Standard guidelines for exceedance probability analysis were used to perform a historical adjustment to the data at the Spreckels gage to assist in plotting the exceedance probability of the two large floods which occurred in 1969 and in 1995. Even though the stream gage data only covered 30 years of data from 1966 to 1996 in the "with reservoirs" condition, these two peak discharges were larger than any peak recorded before, during, or after construction of the two dams; and the largest recorded since 1930.

The Flood Insurance Study for Monterey County reports that there were very notable flood events in 1911 and 1914, both of which, generated significant flood damage. Between 1914 and 1930, no significant flood events were reported. Local newspaper reports of the 1911 flood described it as "the largest known to have occurred since 1862." There was no comparison between the 1911 event and the 1914 flood, which may indicate that although the 1914 flood created huge flood losses, it was not as large as the 1911 event.

There does not appear to be a way to accurately compare the 1911 flood to either the 1995 or the 1969 flood. The 1911 flood was described as "a mile wide in places." This definition also would apply to the 1969 and 1995 floods. If it were known for example that the 1995 flood was definitely larger than the 1911 flood it could be stated that this flood was the largest known to have occurred since at least 1862, a period of 136 years. However, it can only be stated that the 1995 event was the largest known to have occurred since at least 1911, a period of 87 years.

The "historical adjustment" helped to place the 1995 and 1969 floods in a more proper perspective from the standpoint of exceedance probability. All the available data for both locations for both conditions were plotted together on four log-normal graphs.

The frequency curves were developed by first manually fitting a curve through the data points for peak discharge being careful to include the 100-year value from the HEC-1 model. The remainder of the frequency curve for peak discharge was fitted manually using the plotted data points and the plotted HEC-1 model results for the 10-year and 50-year floods. The same procedure was used for the 1-day volume. These two frequency curves (the peak discharge and the average one-day discharge) were then used to guide the fitting of the three-day average flow and the five-day average flow. The portions of the curves in the area of the more frequent floods were adjusted so that the fit of the data points (whether actual gaged data or estimated data from the SVIGSM) was fairly good. The four curves (peak, 1-day, 3-day and 5-day) were then all adjusted to develop a "family of curves" while maintaining the HEC-1 100-year results and providing a reasonable fit to the data in the more frequent portions of the curves.

Section 2 - Flood Control Benefits Analysis

This procedure was repeated for the four different families of frequency curves: two locations - Spreckels and Bradley; and, two conditions - with and without the two reservoirs in place.

The families of curves at each location on the river for the historical condition were subtracted from the families of curves for the "without reservoirs" conditions. These resulting families of difference show graphically the impact of the two reservoirs on the frequency of flood flows along the Salinas River.

The results are shown in Figures 2-2 and 2-3. These curves represent the differences between the "with dams" and the "without dams" exceedance probability curves. The entire four families of exceedance probability curves along with the data points is included in Appendix B.

Conclusions of Flood Control Hydrology Analysis

Figures 2-2 and 2-3 show the differences between the "with" and "without reservoirs" conditions. Discharges along the Salinas River at both the Bradley and Spreckels gages are reduced by the flood control operations of the two reservoirs. For instantaneous peak discharges at Bradley, there is a difference of 78,000 cfs for a 100-year flood (a 1 percent exceedance probability) and a 55,000-cfs difference for the 10-year flood (a 10 percent exceedance probability).

For the five-day average discharge at Bradley, there is an 18,000-cfs decrease in discharge from the operations of the two reservoirs during a 100-year flood. This difference is also 18,000 cfs for a 10-year

flood.

The flood control operations at the two reservoirs appear to have slightly less impact at Spreckels. The total drainage basin area for the two reservoirs is 650 square miles. The Spreckels gage drainage basin is 4,156 square miles. When compared to the drainage basin area for the Bradley gage, which is 2,535 square miles, an increase of 64% in drained area between the gages is noted as one moves downstream. The flood control operations at the two reservoirs appear to have less impact at the Spreckels gage. This is expected since reservoir operations effects are buffered as drainage area and distance from the storage facilities increase.

Figure 2-4 shows the historical data for the two stream gages overlain with the 100-year flood discharges for the "with" and "without reservoirs" cases. The 1969 and 1995 floods stand out as significant events based on the gaged record and on newspaper accounts of floods that occurred before stream gaging.

Table 2-1 shows the instantaneous peak discharges for the 100-year flood with reservoirs and the 100-year flood without reservoirs. Corresponding to the discharge for each reach are two annual exceedance probabilities: one for the "with reservoirs" condition and the other for the "without reservoirs" condition.

The results show that the flood control pools of both reservoirs provide a significant reduction in flood discharges at both the Bradley and Spreckels gaging stations.

Figure 2-2

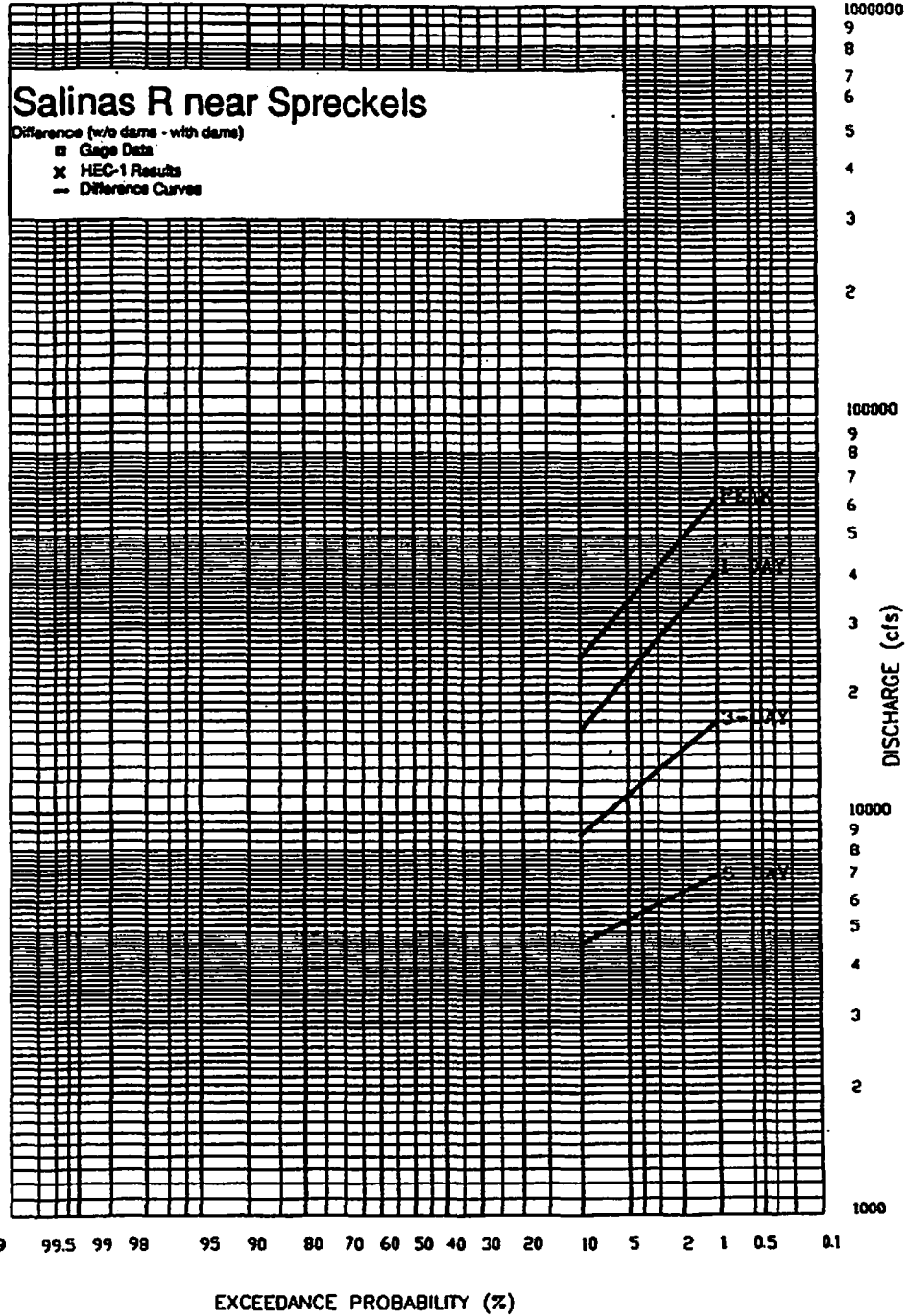

C:\00\HEC\CAS\SP-DIFF.DWG - B/6/97

Figure 2-3

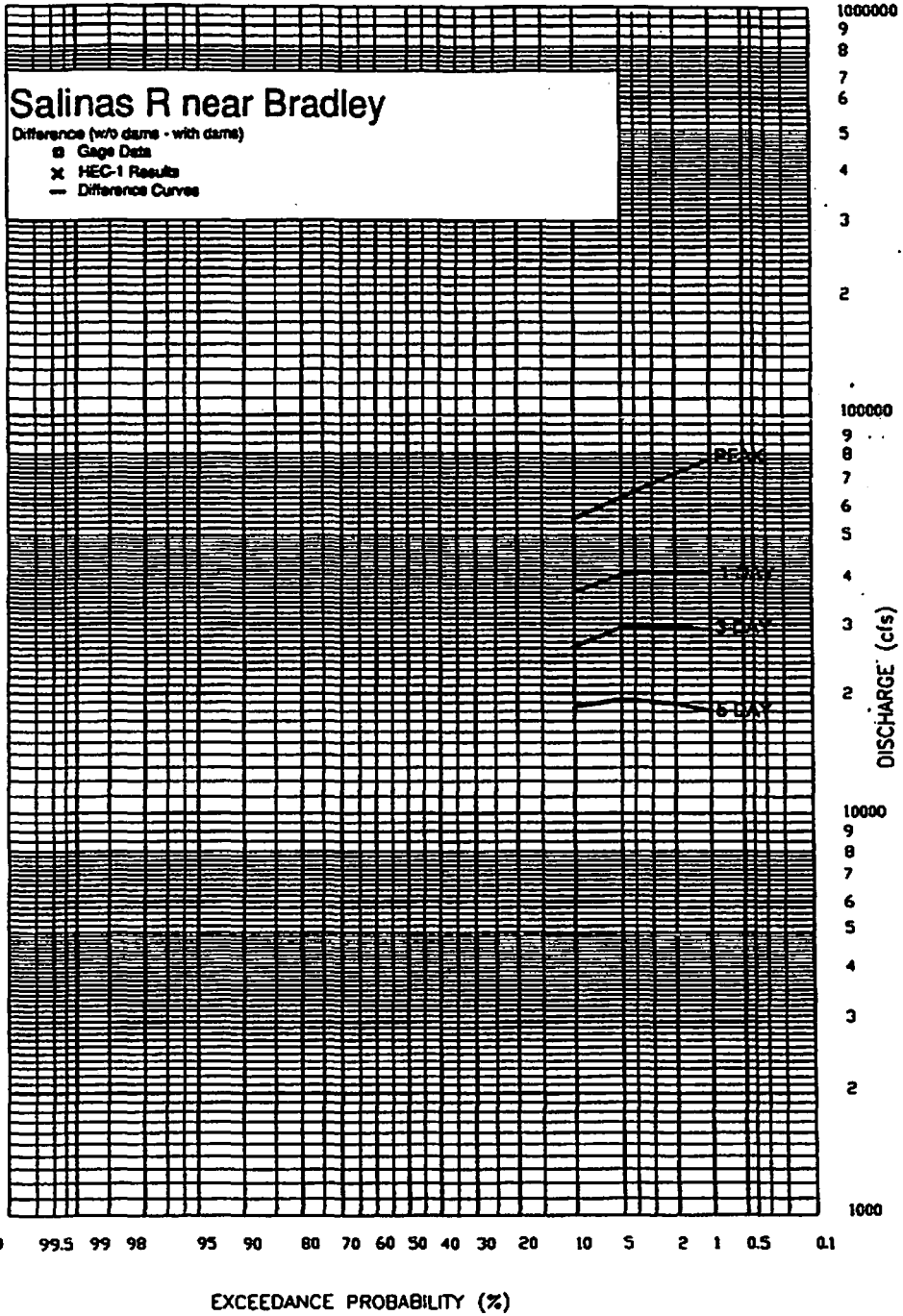

C:\D00\NCE\BR-DIFF.DWG 8/6/97

Figure 2-4

Annual Peak Discharges at Selected Long-Term
U.S. Geological Survey Gaging Stations

SALINAS RIVER AT SPRECKELS

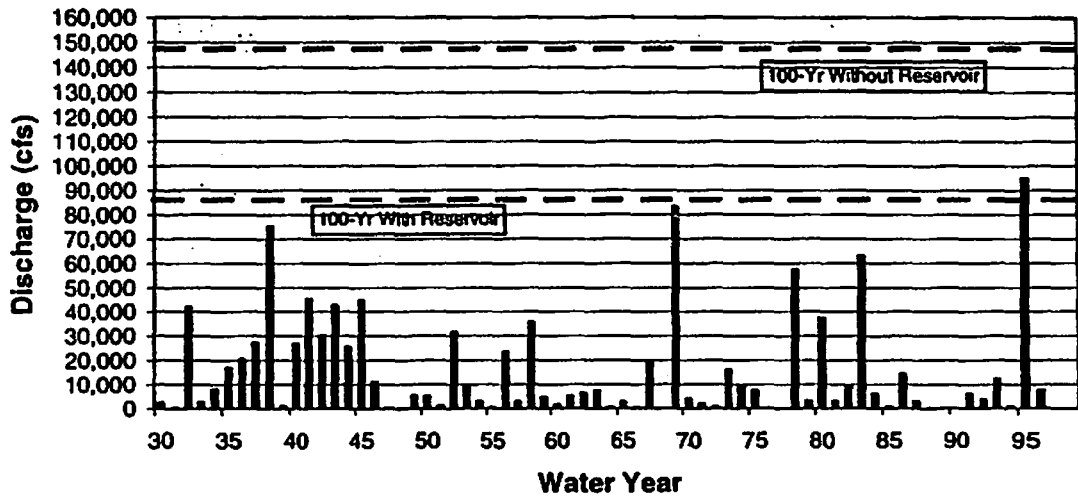

SALINAS RIVER AT BRADLEY

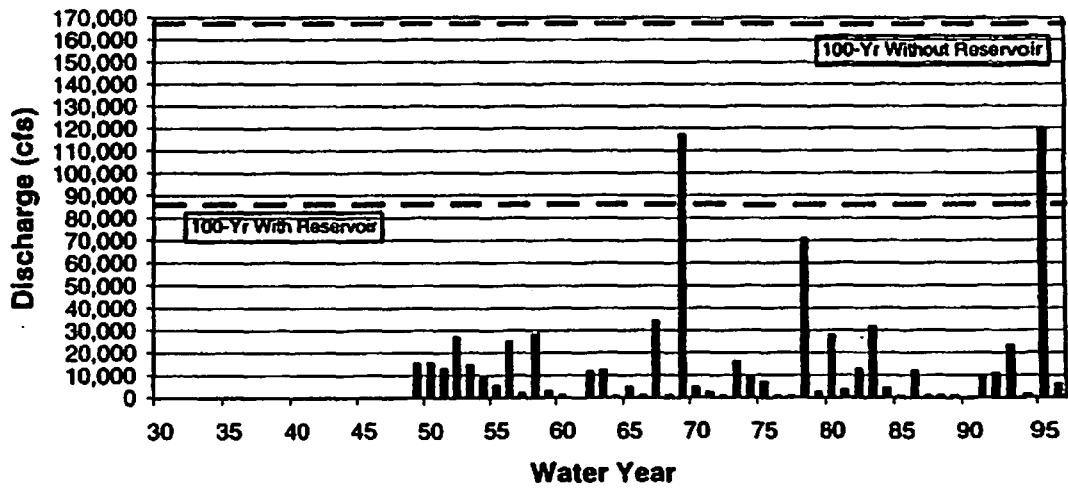

Section 2 - Flood Control Benefits Analysis

**Table 2-1
Salinas River - With and Without Reservoirs
Discharge-Probability Comparison**

| Reach | Q (cfs) | Annual Exceedance Probability | |
|-----------------------------------------------|---------|-------------------------------|--------------------|
| | | With Reservoirs | Without Reservoirs |
| 100-Year Flood With the Reservoirs | | | |
| 1 | 86,000 | 0.01 | 0.045 |
| 2 | 87,000 | 0.01 | 0.055 |
| 3 | 87,000 | 0.01 | 0.065 |
| 4 | 87,000 | 0.01 | 0.074 |
| 5 | 87,000 | 0.01 | 0.083 |
| 6 | 87,000 | 0.01 | 0.093 |
| 7 | 87,000 | 0.01 | 0.10 |
| 8 | 87,000 | 0.01 | 0.11 |
| 9 | 87,000 | 0.01 | 0.12 |
| 100- Year Flood Without the Reservoirs | | | |
| 1 | 149,000 | 0.0015 | 0.01 |
| 2 | 152,000 | 0.0014 | 0.01 |
| 3 | 153,000 | 0.0014 | 0.01 |
| 4 | 154,000 | 0.0013 | 0.01 |
| 5 | 156,000 | 0.0013 | 0.01 |
| 6 | 159,000 | 0.0012 | 0.01 |
| 7 | 162,000 | 0.0012 | 0.01 |
| 8 | 165,000 | 0.0011 | 0.01 |
| 9 | 167,000 | 0.0010 | 0.01 |
| 25- Year Flood With the Reservoirs | | | |
| 1 | 53,000 | 0.04 | 0.14 |
| 2 | 54,000 | 0.04 | 0.14 |
| 3 | 54,000 | 0.04 | 0.16 |
| 4 | 55,000 | 0.04 | 0.16 |
| 5 | 55,000 | 0.04 | 0.18 |
| 6 | 56,000 | 0.04 | 0.18 |
| 7 | 56,000 | 0.04 | 0.20 |
| 8 | 57,000 | 0.04 | 0.20 |
| 9 | 57,000 | 0.04 | 0.21 |

HYDRAULICS AND FLOODPLAIN MAPPING

The determination of discharge probability-duration curves near the upper and lower ends of the 105.8-mile study reach provided all the discharge information needed to develop potential flood-prone areas. This section describes the additional information needed, how it was obtained, and how the floodplain was delineated. Also included are descriptions of the floodplains in the Salinas River Valley along the 105.8-mile study reach.

Base Mapping

Contour maps generated from MCWRA digital orthophotography were used as the base maps for the floodplain delineations. The resulting maps have a 10-foot contour interval (5 feet in certain areas near the Arroyo Seco - Salinas River confluence) which are laid over a scaled orthophoto graph. The orthophotography is resident in the MCWRA's GIS.

The orthophotography covers approximately 88.8 miles of the 105.8-mile study reach. The upper 17 miles of the Salinas River are not included in the MCWRA's GIS. Therefore, existing 1"=2,000' USGS quadrangle maps with a contour interval of 20 feet were utilized.

Cross sections were developed from the contour maps at approximately every 1,000 feet along the study reach. The cross sections were developed from upstream to downstream and are represented by pairs of numbers. Each cross section is represented by pairs of numbers. Each pair of numbers represents a distance from an arbitrary zero point to the left side of that cross section and an elevation associated with that point. Generally the cross-section points were taken on the contour lines.

In the 18.7 miles of the study reach farthest downstream, the FEMA cross sections were used. The data from MCWRA's maps differ from those of FEMA's maps. The FEMA maps were prepared based on a National Geodetic Vertical Datum (NGVD) of 1929 and MCWRA's maps were prepared North American Vertical Datum (NAVD) of 1988. The difference between these data is approximately 2.75 feet in the Salinas Valley. All FEMA information was adjusted to match MCWRA's data. (FEMA has since shifted to the NAVD '88 for all new flood insurance studies.)

Numerous bridges cross the Salinas River in the study area. Under flood conditions, these crossings may create an upstream backwater effect. Embankments leading to the bridges typically act to redirect flood waters through the bridge opening and also may create a backwater effect. The geometry of the existing bridges was obtained from the FEMA study for those bridges included in the investigation. All other bridges were field verified and measured to determine the bridge opening area; the number, size, and configuration of piers; and the height from the stream bed to the low chord of the bridge.

The Salinas River can change during floods, so the cross section after a flood may not be identical to the cross section taken just before a flood. The model used in the floodplain delineation for this assignment does not predict changes to cross sections. The cross sections are assumed fixed. Also, the channel bottom of the Salinas River moves during floods. This fluvial nature of the flood flows was not explicitly considered in the computations. These two factors were, however, implicitly considered in the calibration of the roughness value of the river channel.

Section 2 - Flood Control Benefits Analysis

Roughness Calibration

The Manning's equation as applied to gradually varied flow is the theoretical basis for floodplain delineation process. A significant item in Manning's equation is the roughness value, which represents the retarding effects of the bottom of the channel, the banks, and the overbank areas in the floodplain. The roughness value can be determined by calibrating to a known flood event. Alternatively, the value can be based on engineering judgment.

The 1969 floods along the Salinas River were well documented by the Corps' San Francisco District. The discharges were known from the USGS stream gaging stations. The Corps documented high water marks along the river from the Pacific Ocean up the river valley to south of the Monterey County line. Thus, discharge and, channel cross sectional flow area are known and, leaving the roughness value as the only unknown left in the equation.

The model built from the FEMA cross sections (as modified) and the MCWRA map cross sections was applied to the 1969 high water marks (also modified). The roughness values along the river were then calibrated to the 1969 high water by running the model and adjusting the roughness values in the Salinas River channel until the high water marks were reasonably replicated. Thus, the fluvial nature of the channel and shifting cross sections should be incorporated into this calibration. It must be noted, however, the cross section being used may not necessarily be the one in place when the high water was present.

The same type of roughness value calibration to the larger 1995 flood event was not possible because a comprehensive record of high water marks was not established in the aftermath of that flood.

The 1995 high water marks would be useful because many local residents believe that the river channel is becoming more overgrown with brush and trees because of the summer low flow releases from the two upstream reservoirs for ground water recharge. A review of the flow-duration curves for the Bradley and Spreckels locations indicates that there are higher flows in the "with reservoir" condition than the "without reservoir" condition in the lower end of the discharge spectrum. This means that there is more water on average in the normally low-flow times because of releases from the reservoirs than prior to the construction of the reservoirs. This additional flow is released for ground water recharge and is more prominent at the Bradley gage than at the Spreckels gage.

Although this is an expected change in the flow-duration curves, it does not necessarily translate into larger roughness values for floodplain delineation studies because there is no documented information on how additional vegetation may affect the fluvial nature of the river channel. Although local observations are important and give cause for caution, there is no evidence to use any roughness values for floodplain delineation other than those calibrated to the 1969 flood event.

Levees

In many places along the river, local property owners have constructed levees to help protect their lands from flooding. These levees may help provide protection or, in the case of failure of the levee, may lead to more damage than would have occurred had no levee been present. The efficacy of levees along the river is difficult to determine with any degree of engineering accuracy. Some levees appear to be large, well constructed, and well maintained. Others do not appear to be tied back to high ground, appear worn,

Section 2 - Flood Control Benefits Analysis

filled with rodent holes, breached, lower than neighboring levees, or are only partially complete.

The location of many of the existing levees along the river was obtained from a list compiled by MCWRA staff; however, this list was not complete or comprehensive. Most of the levees on this list were field inspected and top elevations were determined by using the MCWRA's Global Positioning System (GPS).

Because of varying conditions of the levees, floodplain mapping was performed using FEMA's levee policy. The FEMA levee policy (included in Appendix B) states that if the levee does not meet FEMA standards and is not certified by FEMA or by another federal agency, that levee is considered "not to exist" for purposes of floodplain delineation.

The FEMA criteria generally state that for a levee to be considered during floodplain mapping it must meet five criteria:

1. It must have a minimum of 3 feet of freeboard above the 100-year flood elevation with more freeboard required near bridges, near constrictions and near the upstream end of the levee.
2. Must meet Corps of Engineers criteria for embankment protection from scour, for embankment and foundation stability, and for settlement. That is, the levee must be structurally sound.
3. It must have an adequate interior drainage system in place. This system will prevent runoff from local areas from ponding behind the levee and causing flooding and

subsequent flood damage.

4. The levee must not have human intervention to operate. Such operations include sandbagging, flashboards, and earthfill.
5. The system must be maintained in accordance with an officially adopted maintenance plan. A governmental agency must assume ultimate responsibility for maintenance of the levee.

These criteria are, of necessity, quite stringent, because FEMA wants to have a certain degree of confidence that the levees will function as intended when called upon to do so. Levees which meet all of the above criteria and are certified are considered by FEMA as being effective during a 100-year flood. Levees which fail to meet a criterion can not be certified and, therefore, are not considered during the delineation of the 100-year floodplain. The 100-year flood is used by FEMA as its regulatory flood, i.e., the resulting floodplain defines the limits where insurance is required. The floodplain is also identified in a locally adopted floodplain management ordinance as the area where special building code requirements are required.

Because only one levee system is known to have applied for FEMA certification and is in the process of receiving that certification, all other levees are assumed, for purposes of floodplain delineation, to be nonexistent. The only levee system known to have applied for FEMA certification is the one surrounding the sewage treatment works for the City of Soledad.

It is recognized that private levee systems have provided protection to property in large flood events, such as that in 1995. However, these flood protection benefits

can not be certified by the FEMA criteria and, therefore, were not considered in the HBA.

HEC-2 Models

The Corps gradually varied flow water-surface profile computer program (HEC-2) was used to combine the cross sections, the discharges, and the roughness values and to predict elevations of the floodplain at each cross section for the 105.8 miles of study reach. The computer model was used to predict the water surface elevation at each cross section for five different discharge conditions:

- 100-year discharge without dams
- 100-year discharge with dams
- 25-year discharge with dams
- Channel capacity without levees
- Channel capacity with levees

As previously shown in Table 2-1, the discharges with and without reservoirs provide three points along the annual exceedance probability curves for both conditions along the river study reach. For example, on Table 2-1, three discharges are shown for Reach 5. Also shown are the corresponding exceedance probabilities for each of these three discharges under the "with reservoirs" condition. A discharge of 87,000 cfs has an exceedance probability of 0.01 under the "with reservoirs" condition. A discharge of 156,000 cfs has an exceedance probability of 0.0013, and a discharge of 55,000 cfs has an exceedance probability of 0.04. Similarly, Table 2-1 shows the exceedance probabilities corresponding to these three discharges under the "without reservoirs" condition.

The two channel capacity determinations were done to estimate the exceedance probability of when overbank flooding would cause damage and monetary losses. Channel capacity along the river varies

from section to section. However, the channel capacity calculations were done and results presented on a reach-by-reach basis. The channel capacity for a reach was not determined by taking the smallest value and applying it to the entire reach. Rather, the channel capacity value for the reach was based on the discharge that resulted in an estimated one-quarter to one-third of the cross sections in the reach experiencing overbank flooding. The use of the one-quarter to one-third overbank flooding for a reach was thought to be a better representation of when significant damage would start occurring in each reach.

This method was used to escape from absolute reliance on the 10-foot contour maps in determining the capacity. If the lowest capacity at any section in a reach was always selected, it was anticipated that the overall reach capacity figure would undoubtedly predict frequencies which were much too high. The estimate of channel capacity of one-quarter to one-third of the overbanks being subject to some flood waters was thought to be a better estimate of where significant damage started rather than where any damage started.

The levees, as determined by field GPS measurements and 10-foot contour maps, were held in place and assumed not to fail when developing the channel capacities under the "with levees" condition. When determining channel capacities for the "with levees" case, the levees were assumed not to fail but would allow for overtopping.

The results of the channel capacity determinations are shown in Table 2-2. The levees generally increase the capacity prior to flooding the overbank areas by approximately 5,000 to 10,000 cfs. Some reaches did not have significant stretches of levee-protected channel, so there was no

Section 2 - Flood Control Benefits Analysis

**Table 2-2
Channel Capacity Results**

| REACH | CHANNEL CAPACITY WITH LEVEES | | | CHANNEL CAPACITY WITHOUT LEVEES | | |
|-------|------------------------------|-------------------------------|--------------------|---------------------------------|-------------------------------|--------------------|
| | Q (cfs) | Annual Exceedance Probability | | Q (cfs) | Annual Exceedance Probability | |
| | | With Reservoirs | Without Reservoirs | | With Reservoirs | Without Reservoirs |
| 1 | 15,000 | 0.24 | 0.45 | 10,000 | 0.31 | 0.54 |
| 2 | 15,000 | 0.25 | 0.48 | 5,000 | 0.46 | 0.69 |
| 3 | 15,000 | 0.26 | 0.50 | 5,000 | 0.47 | 0.73 |
| 4 | 25,000 | 0.18 | 0.39 | 25,000 | 0.18 | 0.39 |
| 5 | 15,000 | 0.28 | 0.55 | 10,000 | 0.35 | 0.66 |
| 6 | 35,000 | 0.12 | 0.31 | 35,000 | 0.12 | 0.31 |
| 7 | 35,000 | 0.12 | 0.32 | 30,000 | 0.17 | 0.38 |
| 8 | 35,000 | 0.13 | 0.34 | 35,000 | 0.13 | 0.34 |
| 9 | 55,000 | 0.045 | 0.23 | 55,000 | 0.045 | 0.23 |

difference in the capacities for these reaches. In Reach 2, for example, the capacity of the channel with levees is 10,000 cfs greater than the capacity would be without the levees. Under the "with reservoirs" condition (the current condition) the levees change the exceedance probability of overbank flooding from approximately once every two years on the average to approximately once every four years on the average (i.e., the exceedance probability changes from 0.46 to 0.25 per year).

For Reach 2, under the "without reservoirs" condition, the change in channel capacity is still 10,000 cfs, but the annual exceedance probability of flooding changes from 0.69 to

0.48. Meaning, even with the existing levees, the exceedance probability of overbank flooding under the without dams conditions would be approximately equal to the condition today if the levees were removed.

Erosivity

Examination of the potential for erosion damages was part of this flood control benefits study. The 1995 floods resulted in significant amount of damage due to erosion. This erosion caused loss of land near the river banks, washing away top soil, and causing siltation damage to other land.

Section 2 - Flood Control Benefits Analysis

An erosivity factor was developed as an indicator of possible erosion. This erosivity factor was based on interrelating two factors: a soil erodibility factor and the average velocity in the overbank. The soil erodibility factor is published by the Soil Conservation Services in the soil survey for Monterey County. This factor is a "measure of the susceptibility of the soil [type] to erosion by water." The factor is a value between 0.10 and 0.64, with 0.10 being low susceptibility and 0.64 being highly susceptible. The overbank velocity in feet per second was produced for each cross section from the HEC-2 computer model runs.

A qualitative measure of erosivity was established as shown in Table 2-3. The overbank velocities were divided into three categories: fast, medium, and slow. The slow velocity range is from 0 to 2 feet per second, the medium range is from 2 to 4 feet per second, and the fast range is greater than 4 feet per second. Similarly, a qualitative range (the k-value) was established for the Soil Conservation Service's soil erodibility factor with 0.10 to 0.28 being low, 0.28 to 0.46 being medium and 0.46 to 0.64 being high.

The final erosivity index also is a qualitative index with the three categories of high, medium, and low. The categories were established by combining the other two indices as shown in Table 2-3. This erosivity index helps compare erosion damages as documented for the 1995 flood to those of other floods.

Floodplain Mapping

The HEC-2 model was run for three discharges: the 100-year flood with the reservoirs in place; the 100-year flood without the reservoirs; and the 25-year flood with the reservoirs.

At each cross section, the water surface elevation was taken from the HEC-2 output. The extent of the floodplain was plotted on the 1"=1000' orthophoto maps at each cross section. The floodplain was drawn by connecting the floodplain limits at each cross section while ignoring the effects of local levees. There were two exceptions to this mapping procedure. First, the levees around the Soledad treatment plant were accounted for under the "with reservoirs" condition; they were ignored under the 100-year "without reservoirs" condition because the water surface elevation under this condition was higher. With this higher surface elevation, the FEMA-mandated freeboard was very likely not maintained. If a levee does not have freeboard, FEMA will not certify it. Therefore, under the "without reservoirs" condition, the levee would not be high enough to be certified, and would not be considered.

Additionally, an exception was made in the lowest reach near the Pacific Ocean and in and around Castroville. Here, the 10-foot contours could not provide sufficient definition for this very wide floodplain. In 1995, the floodwaters did enter portions of Castroville. In peak discharge, the 1995 flood was somewhere between the 100-year flood with reservoirs and the 100-year flood without reservoirs. Thus, the 100-year floodplain was drawn under the "without reservoirs" condition, the same as the floodplain from the 1995 flood. A greater flood would likely inundate more land in Castroville but the exact amount is uncertain because the ground generally slopes up rather prominently from areas flooded in 1995.

The three floodplains are shown in Plate 1 (enclosed large size map). Additionally, the floodplains have been drawn on a set of 1"=1,000' orthophoto contour maps. The upper end of the study was done on USGS

Section 2 - Flood Control Benefits Analysis

**Table 2-3
Erosion Potential Index Criteria**

| Erosion Potential Index | Velocity | K-value |
|-------------------------|---------------------------------------------------------------------|--------------------------------------------------------------------------|
| LOW | SLOW | LOW |
| | SLOW | MEDIUM |
| | MEDIUM | LOW |
| MEDIUM | SLOW | HIGH |
| | MEDIUM | MEDIUM |
| | FAST | LOW |
| HIGH | MEDIUM | HIGH |
| | FAST | MEDIUM |
| | FAST | HIGH |
| Notes: | <u>Velocity</u> slow: 0-2 fps medium: 2-4 fps fast: >4 fps | <u>K-Value</u> low: 0.10-0.28 medium: 0.29-0.47 high: 0.48-0.64 |

quadrangle sheets. These maps can be found at MCWRA.

In order to analyze the distribution of flood control benefits received from the operation of the reservoirs, Flood Study Units (FSU) are defined. The boundaries of FSUs are approximately delineated based on the inundation areas in each ESU, along the Salinas River. At present, the boundaries of FSUs are not aligned to any institutional features, such as parcel maps. Figure 2-5 shows the boundaries of the FSUs in the Salinas Valley.

CONCLUSIONS

Along most of the river valley there is not a great difference in flood-prone areas between the "with" and "without

reservoirs" conditions. In most of the valley, the floodplain is in an old river terrace and the flood waters extend up to the steep bank which delimits the edge of the terrace. However, the depth of overbank flow for the "without reservoirs" condition varies from 2 feet to as much as 4 feet greater than the 100-year flood with reservoirs. Therefore, although the extent of flooding is approximately the same over most of the river valley, the depth of inundation is not.



Correlating the floodplain maps with the results shown in Table 2-1 leads to the second important flood control aspect of the two reservoirs: the frequency of flooding. The 25-year flood only has a four percent (1-in-25) chance of occurring during any one year with the flood control pools at the

Figure 2-5

Salinas Valley Historical Benefits Analysis

Flood Study Unit Boundaries

LEGEND

-  Flood Study Unit #
-  Areas outside FSU
-  Economic Study Units



Miles

Monterey County
Water Resources Agency

Note: The scale and configuration of all information shown herein are approximate and are not intended as a guide for design or survey work.

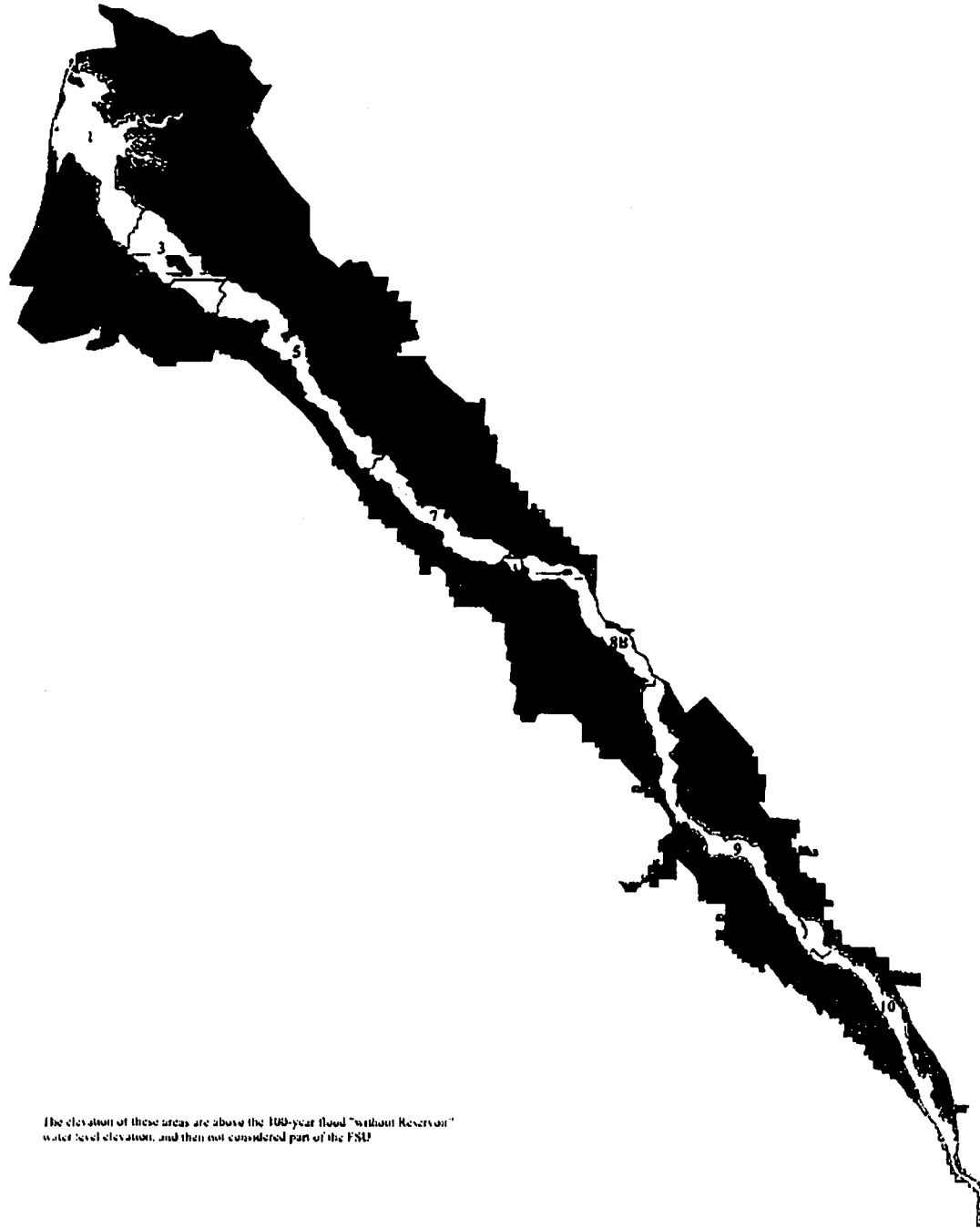

AR 07115

The elevation of these areas are above the 100-year flood "without Reservoir" water level elevation, and then not considered part of the FSU.

Section 2 - Flood Control Benefits Analysis

reservoirs available. This probability of the same river discharges occurring increases from 1-in-25, to 1-in-5 to 1-in-7 for the "without reservoirs" condition. Therefore, the chances are much greater that the equivalent of a "with reservoir" 25-year flood could occur in any one year for the "without reservoirs" condition.

Figure 2-6 shows the cross section at river mile 61.4. The width of floodplain remains relatively the same for the 25-year and the two different 100-year floods. However, the average depth in the overbank changes dramatically, ranging from less than a half a foot for the 25-year flood with reservoirs, to slightly less than 2 feet for the 100-year flood with reservoirs, to slightly over 4 feet for the 100-year flood without reservoirs.

Nacimiento and San Antonio Reservoirs appear to provide significant hydrologic benefits from a flood control standpoint because they 1) reduce the frequency of large floods; 2) reduce the magnitude of the regulatory 100-year flood; 3) allow the reduction in discharge which translates into an average reduction in depth of flooding of 3 feet; and 4) reduce potential overbank velocities reducing potential damages from erosion.

WATER SURFACE ELEVATIONS

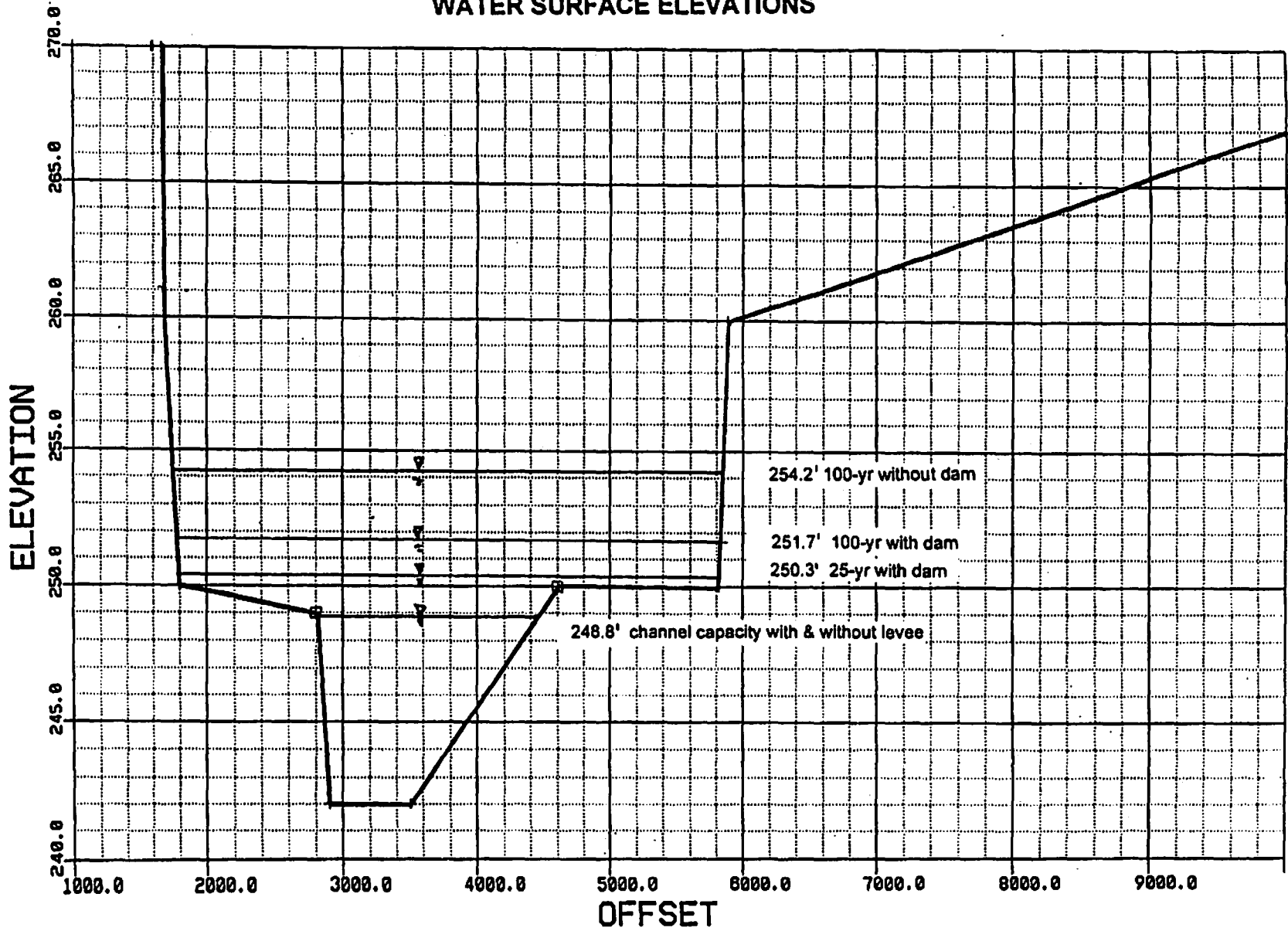

AR 07117

RIVER MILE 61.4

Figure 2-6

Section 3



MONTGOMERY WATSON

AR 07118

Section 3

Economic Benefit Analysis

INTRODUCTION

This section describes the historic, direct economic benefits from the construction and operation of Nacimiento and San Antonio Reservoirs. The economic analysis portion of the historic benefit analysis responds primarily to stakeholders' request for information on the distribution of benefits from the existing project across the Salinas River Basin. The intent of this economic analysis is to estimate the major categories of quantifiable benefits and to display how those benefits have been distributed across the Valley.

While this general approach could be used as part of a cost allocation analysis, that is not the intent of this report. The extent to which historical benefits are relevant for allocating future costs of the existing project or of new projects is not addressed. This approach could also be used to estimate special benefits, which need to be demonstrated to properties before a new assessment can be levied under Proposition 218. Special benefits are defined as particular and distinct benefit over and above the general benefits conferred on real property.

This report also is not intended to present an overall benefit-cost analysis of the existing project; therefore, no attempt has been made to estimate the present value of benefits compared to the present value of project costs. If a full benefit-cost analysis were to be performed, all benefits and costs from the project would need to be considered. These would include benefits or costs to fish and wildlife, recreation, flood control, and water supply, among others.

Economic benefits were determined on the basis of a comparison of conditions

with and without the Nacimiento and San Antonio Reservoirs. Since the reservoirs already exist, it was necessary to estimate the conditions that would have occurred without them. The impacts and associated benefits could then be estimated as the difference between the with and without reservoir conditions.

There were several types of direct economic benefits identified for quantitative estimation, including both water supply and flood control benefits.

Quantified water supply benefits include:

- Avoided costs for ground water pumping
- Avoided costs from drilling new wells or modifying existing wells
- Avoided well costs associated with seawater intrusion.

Quantified flood control benefits include:

- Prevention of agricultural damages including reduction in damages from erosion
- Prevention of damages to buildings and structures.

Other benefits that will be discussed, but are not quantified in this analysis include:

- Water quality benefits outside the intrusion area
- Value of good quality water in storage
- Value of ground water basin for storage and distribution
- Value of reservoir as insurance against rainfall variations
- Recreation and environmental benefits
- Indirect benefits, such as changes in land values and additional regional economic activity created by the direct benefits.

WATER SUPPLY BENEFITS

Approach to Analysis

During the HBA workshops between MCWRA and stakeholders, two approaches were discussed for estimating water supply benefits: a flexible agricultural production model or an avoided cost spreadsheet. A flexible model would be appropriate if changes in water costs would be of a magnitude that would cause changes in farm management decisions, or if water availability was an issue. The initial hydrological results from SVIGSM indicate that water availability is not a significant problem. Crop budget studies by University of California at Davis show that ground water costs account for a small part of the production cost for the high valued crops grown in the area; water costs vary from three to five percent of the total production cost for different crops. Therefore, ground water impacts would not substantially affect the crop mix, acreage planted, cropping intensity, and irrigation practices. For these reasons, the avoided cost approach was selected. The water supply economic benefits analysis was conducted using several avoided cost spreadsheets. The detailed approach and results from the analyses for each of the three water supply economic benefits categories are discussed below.

Avoided Costs for Ground Water Pumping

Table 3-1 presents the annual avoided ground water pumping cost by Economic Study Units (ESU). The areas included in each ESU are shown in Figure 1-13 in Section 1. The ground water level increase, shown in column (1) of Table 3-1, is the change in the weighted average ground water levels with and without the reservoirs. The ground water levels were estimated by the SVIGSM and weighted by the monthly ground water pumping pattern and by geographical distribution of pumping. Ground water levels weighted by pumping (both geographically and overtime) must be used because they reflect ground water levels most relevant to the areas where pumping occurs and during the months when pumping occurs. The example below illustrates how this weighting can result in a difference between a simple and weighted average. Although the example shown below shows a potential underestimation of changes in ground water levels when using a simple average, overestimation is also possible. For this reason, the weighted average is used in this economic analysis to achieve the most appropriate results.

| | Quantity Pumped in Acre Feet | | Lift Difference in Feet | |
|--------|------------------------------|---------|-------------------------|---------|
| | Month 1 | Month 2 | Month 1 | Month 2 |
| Node 1 | 100 | 150 | 10 | 20 |
| Node 2 | 50 | 75 | 10 | 10 |

NOTES:
 Simple Average = $(10+20+10+10)/4 = 12.5$ feet.
 Weighted Average = $(100 \times 10 + 150 \times 20 + 50 \times 10 + 75 \times 10) / (100+150+50+75) = 14$ feet.

Section 3 - Economic Benefit Analysis

TABLE 3-1

Annual Avoided Ground Water Pumping Costs by ESU
1958-1994 Average

| | (1) | (2) | (3) | (4) | (5) | (6) |
|---------------------------|-------------------------------------|---------------------------------------------------------|------------------------------------------------------|-------------------------------------------------|---------------------------------------------|-------------------------------------------------|
| Economic Study Unit (ESU) | GW Level Increase ¹ (ft) | Avoided Pumping Cost Per Acre-Foot ² (\$/af) | Ground water Pumped for Irrigation ³ (af) | Avoided Pumping Cost Per Year ⁴ (\$) | Average Annual Irrigated Acres ⁵ | Avoided Pumping Cost Per Acre ⁶ (\$) |
| ESU1 | 4.5 | \$1.01 | 42,573 | \$43,104 | 20,583 | \$2.09 |
| ESU2 | 14.2 | \$3.20 | 51,486 | \$164,498 | 17,912 | \$9.18 |
| ESU3 | 16.9 | \$3.80 | 39,297 | \$149,427 | 18,402 | \$8.12 |
| ESU4 | na | na | na | na | na | na |
| ESU5 | 26.9 | \$6.05 | 48,422 | \$293,074 | 20,641 | \$14.20 |
| ESU6 | 23.3 | \$5.24 | 34,108 | \$178,811 | 18,354 | \$9.74 |
| ESU7 | 16.0 | \$3.60 | 64,900 | \$233,640 | 21,234 | \$11.00 |
| ESU8A | 5.9 | \$1.33 | 47,222 | \$62,687 | 17,456 | \$3.59 |
| ESU8B | 6.4 | \$1.44 | 47,746 | \$68,754 | 15,945 | \$4.31 |
| ESU9 | 9.7 | \$2.18 | 120,960 | \$263,995 | 31,850 | \$8.29 |
| ESU10 | 2.3 | \$0.52 | 31,902 | \$16,509 | 11,403 | \$1.45 |
| ESU11 | na | na | na | na | na | na |

NOTE:

1. Ground water level increase is based on SVIGSM estimates. The numbers are weighted by monthly ground water pumped.
2. Ground water pumping cost includes energy and operations and maintenance (O&M) costs. Based on information provided by Pacific Gas & Electric Agricultural Services, the ground water pumping electricity rate in Monterey County averages 12 cents per kwh. With an average pumping efficiency of 60 percent and O&M cost of 2 cents per af per foot, the average pumping cost is about 22.5 cents per af per foot. In the Salinas Valley, this rate is applicable for both agricultural and M&I water users.
3. Based on SVIGSM results.
4. Column 4 = Col. 2 x Col. 3.
5. Based on SVIGSM land use input data, including agricultural and M&I acreage.
6. Column 6 = Col. 4/Col.5.

Column (2) of Table 3-1 shows the avoided pumping cost per acre-foot (af) of ground water pumping. It equals the ground water level increase multiplied by the pumping cost, estimated to be 22.5 cents per af per foot of lift. The 22.5 cent pumping cost includes both the energy cost and O&M cost. Because more than 95 percent of the wells in the Salinas Valley are powered with electricity, energy costs were estimated based on

electric rates for Pacific Gas & Electric (PG&E) Agricultural Service in the Salinas Valley. Based on PG&E's pump test reports, the typical electric rate is about 12 cents per kilowatt hour (kwh) and average pumping efficiency is about 60 percent. The energy cost per acre-foot per foot of lift is then estimated using the following formula:

Section 3 - Economic Benefit Analysis

$$\begin{aligned} \text{Energy Cost} &= \frac{1.02 \times \text{Electricity Rate (\$/kwh)}}{\text{Pumping Efficiency}} \\ &= \frac{1.02 \times \$0.12}{60\%} \\ &\cong \$0.205 \text{ per af per foot.} \end{aligned}$$

The O&M cost is assumed to be 10 percent of the energy cost, or about 2 cents.

Column (3) of Table 3-1 shows the average annual amount of ground water pumped between 1958 and 1994, based on data compiled for the SVIGSM estimates. Column (4) equals Column (2) multiplied by Column (3). Column (5) presents average annual total developed acres, including both agricultural and M&I use.

Column (6) equals column (4) divided by column (5), and shows the avoided pumping cost per acre. These avoided pumping costs represent average annual savings in ground water pumping cost due to construction and operation of the reservoirs. Because the pumping costs savings are dependent upon the changes in ground water levels, the cost savings vary among the ESUs. Smaller per acre savings are estimated in ESUs 1, 8A, 8B, and 10. The greatest savings are estimated in ESUs 5 and 7.

Avoided Cost from Drilling New Wells or Modifying Existing Wells

The second category of water supply economic benefits includes the costs avoided for drilling new wells or modifying existing wells. For some areas, the decline in ground water levels would necessitate additional capital outlay. Pump Bowls would be lowered or wells replaced if water levels drop far enough under the "without reservoirs" condition. This section estimates the avoided cost for making these changes. The annual avoided cost from drilling supplemental

wells and replacing or modifying existing wells are presented by ESU in Table 3-2.

Column (1) of Table 3-2 shows the number of production wells in each ESU. Because actual records of the production wells are not available, these numbers were estimated based on the information provided by the MCWRA Geographic Information System (GIS) and Ground Water Extraction Management System (GEMS) database, using the following formula:

$$\# \text{ of wells} = \frac{\text{Irrig. acres (acre)} \times \text{Applied water per acre (af / acre)}}{\text{Average well production (af)}}$$

Column (2) of Table 3-2 shows the estimated percentage of wells with performance impacts. The estimates of affected wells are derived from the comparison of simulated ground water levels with well construction information as discussed in Section 1. As summarized in Appendix C, Table C-1, the affected wells are divided into two groups: those needing replacement with new wells and those needing modification. The distinctions were made based on more detailed comparisons between monthly ground water elevations and well perforations. For detailed discussion, please see Section 1, Hydrologic Benefits Analysis. The results shown in Appendix C, Table C-1 are for the hydrologic subareas and are applied to all ESUs within the subarea. The relationship between hydrologic subareas and ESUs are shown in Table 3-3.

Column (3) of Table 3-2 is the product of columns (1) and (2). It shows the estimated number of affected wells, divided into the number of new and modified wells required.

Column (4) presents the total annual avoided cost of drilling new wells and modifying wells for each ESU. Column (5)

Section 3 - Economic Benefit Analysis

**TABLE 3-2
Annual Avoided Well Cost From Drilling New
Wells or Modifying Wells By ESU**

| Economic Study Unit (ESU) | (1) | (2) | | (3) | | (4) | (5) | (6) |
|---------------------------|------------------------------------|-------------------------------------------|----------|---------------------------------------|----------|---------------------------------------------|---------------------------------------------|----------------------------------------------------------------|
| | Total Number of Wells ¹ | Percentage of Affected Wells ² | | Number of Affected Wells ² | | Total Annual Avoided Well Cost ⁴ | Average Annual Irrigated Acres ⁵ | Average Avoided Well Cost Per Irrigated Acre ⁶ (\$) |
| | | New Well | Modified | New Well | Modified | | | |
| 1 | 138 | 0.0% | 1.6% | 0 | 2 | \$980 | 17,981 | \$0.05 |
| 2 | 241 | 0.0% | 1.2% | 0 | 3 | \$1,282 | 15,393 | \$0.08 |
| 3 | 146 | 0.0% | 1.6% | 0 | 2 | \$1,041 | 13,147 | \$0.08 |
| 5 | 129 | 0.0% | 1.6% | 0 | 2 | \$917 | 19,721 | \$0.05 |
| 6 | 133 | 0.0% | 1.2% | 0 | 2 | \$710 | 18,503 | \$0.04 |
| 7 | 160 | 0.0% | 0.0% | 0 | 0 | \$0 | 20,170 | \$0.00 |
| 8A | 133 | 0.0% | 0.0% | 0 | 0 | \$0 | 17,439 | \$0.00 |
| 8B | 112 | 0.0% | 0.0% | 0 | 0 | \$0 | 14,744 | \$0.00 |
| 9 | 271 | 8.0% | 0.0% | 22 | 0 | \$68,337 | 32,336 | \$2.11 |
| 10 | 60 | 8.0% | 0.0% | 5 | 0 | \$15,531 | 8,627 | \$1.80 |

NOTE:

1. Total number of wells estimated on basis of GEMS average well production data, total ground water pumped, and irrigated acres (irrigated acres times applied water per acre divided by average well production).
2. Based on SVIGSM Results, see Table 1-5.
3. Column 3 = Col. 1 x Col. 2.
4. All affected wells in ESU 1 to ESU 8 would be required to lower bowls only. The avoided cost for lowering bowls is \$5,000 per well and the cost is amortized over the remaining life of wells. Based on MCWRA well construction data, the average remaining life of the affected wells is about 30 years for a 50-year well life.
5. All affected wells in ESU 9 and ESU 10 would be redrilled based on "medium cost" shown in Appendix C, Table C-1. Avoided well cost is the cost of redrilling not of straight-line depreciation of existing well. Based on MCWRA well construction data, all the affected wells would have been redrilled in 1960 with an average age of 20 years for a 50 year well life.
6. Based on SVIGSM land use input data.
6. Column 6 = Col. 4/Col. 5.

TABLE 3-3

Hydrologic Subareas and Economic Study Units (ESU)

| Hydrologic Subarea | ESU |
|----------------------|---------|
| Pressure Subarea | 1,3,5 |
| East Side Subarea | 2,6 |
| Forebay Subarea | 7,8A,8B |
| Upper Valley Subarea | 9,10 |

shows irrigated acres and column (6) presents avoided well costs per irrigated acre. The detailed calculation for the avoided cost of drilling new wells is illustrated in Table 3-4 for ESU 9. Similar calculations were made for other affected ESUs.

As shown in Table 3-2, all affected wells in ESUs 9 and 10 would require replacement with new wells or drilling of additional wells to supplement existing well production. The avoided cost of constructing new wells is estimated to be

Section 3 - Economic Benefit Analysis

\$2.11 per acre in ESU 9 and \$1.80 per acre in ESU 10.

The detailed calculation for the avoided cost of modifying wells is illustrated in Table 3-5 for ESU 1. Similar calculations apply to the other ESUs.

As shown in Table 3-2 all affected wells in ESUs 1 through 6 would only require lowering bowls. Based on calculations similar to those made for ESU 1, the avoided cost of modifying wells is estimated to be about 4 to 8 cents per acre among the ESUs.

Avoided Well Cost from Seawater Intrusion

The third category of water supply economic benefits includes the avoided costs for wells that would have been replaced in the absence of the reservoirs due to seawater intrusion. Table 3-6 shows the estimates of the annual avoided well costs due to seawater

intrusion by ESU. Additionally, when a well is lost to seawater intrusion, the land owner will try to locate a replacement well as far inland from the intruded well as the property boundary will allow. This situation will sometimes result in the need to extend irrigation lines to the replacement well. The additional costs for extending the irrigation line system has not been included in this analysis.

Seawater intrusion under historical and "without reservoirs" conditions occurs only in ESU 1 (See Section 1, Hydrologic Benefits Analysis). An actual count of irrigation wells that would have been affected by seawater intrusion without the reservoirs was not possible because field inventories of existing wells have not been performed on a regular basis. Therefore, an alternative method of estimating the number of affected wells was developed and is discussed below.

TABLE 3-4

Detailed Calculation of Avoided Cost of Drilling New Wells: ESU 9

| | | |
|---------------------------------------------------------------------------------------------------------------------------------------------------------------------------------------------------------------------------|-------------------------------------------|-------------|
| Number of wells to be replaced | a | 22 |
| Average well age (years) | b | 20 |
| Assumed well life (years) | c | 50 |
| New well cost (\$/well) | d | \$48,000 |
| Existing well cost (\$/well) | e | \$25,000 |
| Straight-line depreciation of existing wells | $f = a \cdot e \cdot (b/c)$ | \$220,000 |
| Cost of new wells | $g = a \cdot d$ | \$1,056,000 |
| Avoided well costs | $h = g - f$ | \$836,000 |
| Annualized cost | $i = h \cdot (0.08174)$ (8%, 50 years) | \$68,337 |
| Average Annual Irrigated Acres | j | 32,336 |
| Annual avoided cost per acre (\$/acre) | $k = i/j$ | \$2.11 |
| NOTES: | | |
| 1. Average well age is based on historic MCWRA well construction data. | | |
| 2. Based on information on existing well depths and conversations with well drillers in Salinas Valley. The depth of new wells is assumed to be 400 feet and the well cost information is shown in Appendix C, Table C-2. | | |
| 3. Based on information on existing well depths and conversations with well drillers in Salinas Valley. The depth of existing well is assumed to be 200 feet and the cost information is shown in Appendix C, Table C-2. | | |
| 4. Based on SVIGSM land use input data. | | |

Section 3 - Economic Benefit Analysis

TABLE 3-5
Detailed Calculation of Avoided Cost of Modifying Wells: ESU 1

| | | |
|------------------------------------------------------------------------|-----------------------------------------------|----------|
| Number of wells requiring lowered bowls | a | 2 |
| Average well age (years) | b | 30 |
| Assumed well life (years) | c | 50 |
| Cost of lowering bowls (\$/well) | d | \$5,000 |
| Avoided cost of lowering bowls | $e = a \cdot d$ | \$10,000 |
| Annualized cost | $f = e \cdot (0.102)$ (8%, c-b = 20 years) | \$1,020 |
| Irrigated acres | g | 17,981 |
| Annual avoided cost per acre (\$/acre) | $h = f/g$ | \$0.06 |
| NOTES: | | |
| 1. Average well age is based on historic MCWRA well construction data. | | |
| 2. Based on telephone survey results shown in Appendix C, Table C-3. | | |

Column (1) of Table 3-6 shows an estimate of additional irrigated acres that would have been affected by seawater intrusion without the reservoirs. The acreage is shown for two aquifer layers: the Pressure 180-foot Aquifer, and the Pressure 400-foot Aquifer (for definitions of aquifer layers, see Section 1). These acreages were derived in two steps. First, seawater intrusion areas under "with" and "without reservoirs" conditions were estimated by SVIGSM. The difference of the two areas, called the intrusion band, was defined as the project benefit (or avoided cost) area. Second, the extent of the band in each layer was used as input in GIS, to estimate the irrigated acreage within the band.

Column (2) of Table 3-6 shows average applied water for truck crops in the band. Truck crops were chosen because they represent most of the irrigated acreage in the seawater intrusion area.

Column (3) shows the average well production based on information provided from GEMS. Column (4) shows the estimated number of wells that would have been affected. It was estimated as column (1) times column (2) divided by column (3).

Column (5) presents total avoided well costs due to seawater intrusion, and column (6) shows total irrigated acres. Column (7) shows avoided well cost per acre, which is column (5) divided by column (6).

The detailed calculations of the annual avoided well cost due to seawater intrusion in the Pressure 180-foot Aquifer for ESU 1 is shown in Table 3-7, and for the 400-foot Aquifer is shown in Table 3-9.

Summary of Water Supply Benefits

A summary of the water supply economic benefits by ESU for the three categories of water supply economic benefits is presented in Table 3-9. A direct sum of all three categories of benefits in ESU 1 is not conceptually consistent because the benefits due to seawater intrusion are only through 1994. Overall benefits for ESUs 1, 8A, 8B, and 10, are all under \$5 per acre, and are substantially smaller than other ESUs. ESU 5 has the highest avoided cost of \$14.20 per acre while the cost for ESU 7 is \$11.00 per acre. All other ESUs have similar benefits, falling in a range just under \$10 per acre per year.

Section 3 - Economic Benefit Analysis

TABLE 3-6

Annual Avoided Well Cost Due to Seawater Intrusion By ESU in 1994

| | (1) | (2) | (3) | (4) | (5) | (6) | (7) |
|-----------------------------------|---------------------------------------------------------------------------|------------------------------------------------------|-----------------------------------------------------|-----------------------------------------------------------------------|-------------------------------------------------|------------------------------------------|----------------------------------------------------|
| Economic Study Units (ESU) | Additional Irrigated Acres Affected Without Reservoirs¹ | Applied Water Per Acre² acre-feet. | Average Well Production³ gal/well | Number of Wells Likely Affected Without Reservoirs⁴ | Total Avoided Well Cost (\$)⁵ | Total Irrigated Acres⁶ | Avoided Well Cost Per Acre (\$)⁷ |
| 1 | | | | | | | \$13.43 |
| 180-Foot Aquifer | 4,917 | 2.04 | 306 | 33 | \$104,848 | 17,981 | \$5.83 |
| 400-Foot Aquifer | 1,211 | 2.04 | 306 | 8 | \$136,635 | 17,981 | \$7.60 |
| 2 | 0 | | | | | | \$0.00 |
| 3 | 0 | | | | | | \$0.00 |
| 5 | 0 | | | | | | \$0.00 |
| 6 | 0 | | | | | | \$0.00 |
| 7 | 0 | | | | | | \$0.00 |
| 8A | 0 | | | | | | \$0.00 |
| 8B | 0 | | | | | | \$0.00 |
| 9 | 0 | | | | | | \$0.00 |
| 10 | 0 | | | | | | \$0.00 |

NOTES:

1. Includes both layer 1 and layer 2 intrusion, based on SVIGSM results (primarily truck crop acreage).
2. Based on SVIGSM applied water for truck crops.
3. Based on average well capacities and operations in the Pressure Subarea. See Appendix C, C-2, note 4.
4. Column 4 = Col. 1 x Col. 2/Col.3.
5. Of the wells within the additional layer 1 intruded area, 65% are assumed to be drilled into layer 2, so do not need to be redrilled. The 35% that are affected are assumed to be redrilled based on the "medium-high cost" shown in Appendix C, Table C-2. Of the potentially affected wells in the layer 2 intrusion area, all would be redrilled based on "high cost" shown in Appendix C, Table C-2. Detailed calculations of annual avoided well costs are shown in Tables 3-7 and 3-8.
6. Based on SVIGSM land use input data.
7. Column 7 = Column 5/Column 6.

Section 3 - Economic Benefit Analysis

TABLE 3-7
Detailed Calculation of Avoided Well Cost due to Seawater Intrusion: 180-foot Aquifer, ESU 1

| | | Well | Pump |
|-------------------------------------------------------------------------|-----------------------------------------------------------------------------------------------|-------------|-----------|
| Number of wells/pumps affected | a | 33 | 33 |
| % of affected wells/pumps already drilled to 400-foot Aquifer | b | 65% | 65% |
| Number of affected wells/pumps needed to be drilled to 400-foot Aquifer | $c = a*(1-b)$ | 11.55 | 11.55 |
| Average age (years) | d | 22.3 | 20 |
| Assumed life (years) | e | 50 | 20 |
| New well /pump cost (\$ per unit) | f | \$120,000 | \$30,000 |
| Existing well /pump cost (\$ per unit) | g | \$48,000 | \$20,000 |
| Straight-line depreciation of existing wells/pumps | $h = c*g*(d/e)$ | \$247,262 | \$231,000 |
| Cost of new wells/pumps | $i = c*f$ | \$1,386,000 | \$346,500 |
| Avoided well/pump costs | $j = i - h$ | \$1,138,738 | \$115,500 |
| Annualized cost | $k_{well} = j * 0.08174$ (8%, 50 years) $k_{pump} = j * 0.101856$ (8%, 20 years) | \$93,083 | \$11,764 |
| Irrigated acres | l | 17,981 | |
| Annualized avoided cost per acre (\$/acre) | $m = (k_{well} + k_{pump}) / l$ | \$5.83 | |

NOTES:

1. Based on vertical distribution of pumping as established in the SVIGSM.
2. Average well and pump age is based on historic MCWRA well construction data.
3. Based on information on existing well depths and conversations with well drillers in Salinas Valley. The depth of new wells is assumed to be 600 feet and the cost information is shown in Appendix C, Table C-2.
4. Based on information on existing well depths and conversations with well drillers in Salinas Valley. The depth of existing wells is assumed to be 400 feet and the cost information is shown in Appendix C, Table C-2.

TABLE 3-8
Detailed Calculation of Avoided Well Cost due to Seawater Intrusion: 400-foot Aquifer, ESU 1

| | | Well | Pump |
|----------------------------------------------------|-----------------------------------------------------------------------------------------------|-------------|-----------|
| Number of wells/pumps affected | a | 8 | 8 |
| Average well age (years) | b | 22.3 | 20 |
| Assumed well life (years) | c | 50 | 20 |
| New well /pump cost (\$ per unit) | d | \$250,000 | \$40,000 |
| Existing well /pump cost (\$ per unit) | e | \$120,000 | \$30,000 |
| Straight-line depreciation of existing wells/pumps | $f = a*e*(b/c)$ | \$428,160 | \$240,000 |
| Cost of new wells/pumps | $g = a*d$ | \$2,000,000 | \$320,000 |
| Avoided well/pump costs | $h = g - f$ | \$1,571,840 | \$80,000 |
| Annualized cost | $i_{well} = h * 0.08174$ (8%, 50 years) $i_{pump} = h * 0.101856$ (8%, 20 years) | \$128,487 | \$8,148 |
| Irrigated acres | j | 17,981 | |
| Annualized avoided cost per acre (\$/acre) | $k = (i_{well} + i_{pump}) / j$ | \$7.60 | |

NOTES:

1. Average well and pump age is based on MCWRA well construction information.
2. Based on information on existing well depths and conversations with well drillers in Salinas Valley. The depth of new wells is assumed to be 1000 feet and the cost information is shown in Appendix C, Table C-2.
3. Based on information on existing well depths and conversations with well drillers in Salinas Valley. The depth of existing wells is assumed to be 600 feet and the cost information is shown in Appendix C, Table C-2.

Section 3 - Economic Benefit Analysis

TABLE 3-9

Summary of Water Supply Benefits by ESU

| Economic Study Units (ESU) | Ground water Level Increases | | Seawater Intrusion in 1994 |
|----------------------------|--------------------------------------|-----------------------------------|---------------------------------------|
| | Annual Avoided Pumping Cost Per Acre | Annual Avoided Well Cost Per Acre | Avoided Annualized Well Cost Per Acre |
| 1 | \$2.09 | \$0.05 | \$13.43 |
| 2 | 9.18 | 0.08 | 0 |
| 3 | 8.12 | 0.08 | 0 |
| 4 | n/a | n/a | n/a |
| 5 | 14.20 | 0.05 | 0 |
| 6 | 9.74 | 0.04 | 0 |
| 7 | 11.00 | 0 | 0 |
| 8A | 3.59 | 0 | 0 |
| 8B | 4.31 | 0 | 0 |
| 9 | 8.29 | 2.11 | 0 |
| 10 | 1.45 | 1.80 | 0 |
| 11 | n/a | n/a | n/a |

FLOOD CONTROL BENEFITS

Flood control benefits are estimated for two categories: prevention of agricultural damages, and prevention of damages to buildings and structures. The detailed approach and results from the analysis for each of the two categories are discussed below.

Prevention of Agricultural Damages

The estimates of historical flood control benefits for agriculture are based on (1) increases in net farm income, and (2) reductions in the costs for the repair of flood damages. The increases in net farm income were measured using information from crop budgets and historical floods. Repair costs include grading; leveling; sediment and debris removal; and replacement or repair of damaged irrigation equipment, wells, and other farm equipment. The benefits from avoided repair costs occur both on (1) lands not flooded as a result of the reservoirs, and (2) lands flooded in either

case, but with a reduced water velocity and duration of flooding with the reservoirs, and (3) lands flooded less frequently due to the reservoirs.

Figure 3-1 shows a hypothetical floodplain under "with" and "without reservoirs" conditions to illustrate some of the factors considered in the analysis. Farm income benefits were measured for the areas that would not be flooded because of the protection provided by the reservoirs (represented by last bar of shaded area in Figure 3-1 designated as the "incremental area flooded"). Avoided cost of repair benefits were measured for the entire floodplain above the river channel. As discussed in Section 2, flood benefits are realized only within the flood zones of the Salinas River in each ESU, not over the entire ESU. These flood zones were designated as FSUs and are shown in Figure 2-5. Therefore, the economic benefits from flood control determined in this section are also calculated on an FSU basis.

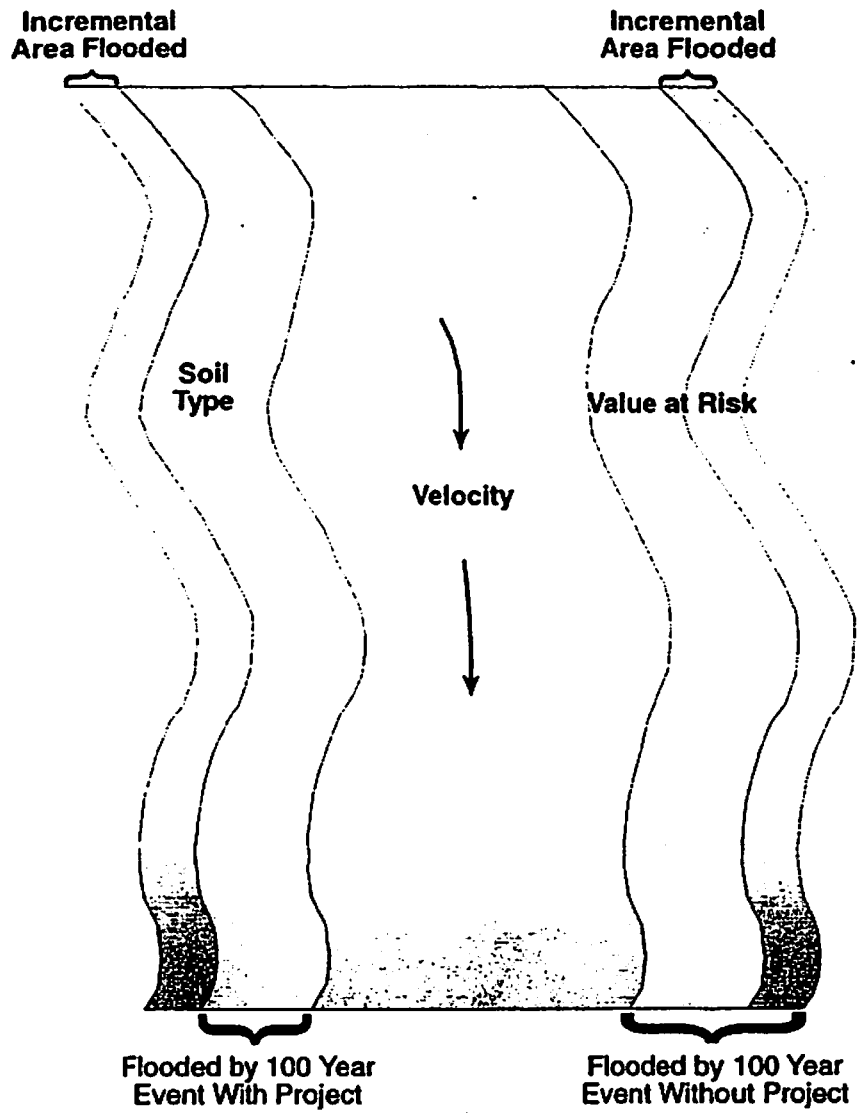

Figure 3-1.
**Important Factors to Consider in Flood Control
 Economic Evaluation**

Section 3 - Economic Benefit Analysis

Physical Data Inputs

The following hydrologic, acreage, and flood frequency information was used in the analysis.

1. Area flooded and crop mix for a 25-year flood event "with" the reservoirs, and the exceedence frequency "without" the reservoirs for the same flooded area, crop mix, and flood flow.
2. Area flooded and crop mix for a 100-year flood with the reservoirs, and exceedence frequency without the reservoirs for the same flooded area, crop mix, and flood flow.
3. Area flooded and crop mix for a 100-year flood without the reservoirs, and exceedence frequency with the reservoirs for the same flooded area, crop mix, and flood flow.
4. Channel capacity with levees in cfs and the exceedence frequency of this flow with and without the reservoirs. No irrigated acreage is flooded at a flow less than this amount, so this item provides an additional frequency-acreage data point for each scenario.

For each of two scenarios (with and without reservoirs) data items 1 through 4 provide four exceedence frequencies and acreage points used to estimate annual average acreage flooded. The crop mix from the 100-year flood area was used to identify representative crops for the estimates of lost income. The crop mix was determined using the 1995 GIS land use data provided by MCWRA.

Two additional physical data inputs were used to estimate the repair costs for flood damages.

5. Erosivity of land in the 100-year floodplain "with" reservoirs was

provided for cross sections of the floodplain on Salinas Valley base maps in color-coded form. This information was provided for conditions with and without the reservoirs. The difference between the with and without conditions accounts for the benefit of reduced velocity of water over lands flooded. The acreage of any land that changed in erosivity between the with and without conditions was estimated as the amount of average length of cross section that changed, times half of the distance between the two adjacent cross sections.

6. Erosivity of the additional land flooded in the 100-year floodplain under without reservoirs conditions was provided for cross sections of the floodplain on Salinas Valley base maps in color-coded form. The acreage of any medium or high erosivity acreage was estimated as the length of the medium or high erosivity cross section times half the distance between the two adjacent cross sections, and the area of low erosivity was estimated by subtraction from the total change (without reservoirs minus with) in flooded acreage. The methodology for determining the total change in flooded acreage is discussed in Section 2.

Farm Income Losses

Crop production losses occur during flooding because (1) a crop in the ground is destroyed or diminished in value, or (2) a crop cannot be planted. Economic data on loss per acre flooded were developed from information provided by the Monterey County Agricultural Commissioner (MCAC), California Department of Food and Agriculture (CDFA), the University of California

Section 3 - Economic Benefit Analysis

Cooperative Extension Service (UCCES), the U.S. Bureau of Reclamation (USBR) and discussions with local growers.

Crop mix data were provided by the County. A comparison of the crop mix for the areas flooded under conditions with and without reservoirs is presented in Table 3-10. Since over 90 percent of the acreage flooded is devoted to truck crops, the greatest of attention was given to this crop category.

Growers were interviewed to identify truck crops that would typically be grown at the time of flooding. MCAC provided

1985 through 1995 average revenues per acre for head lettuce, leaf lettuce, and cauliflower (MCAC 1985-1995). UCCES (1992) provided crop production costs for lettuce. No representative crop production cost data were available for Monterey County. Costs for leaf lettuce and cauliflower were developed from commercial crop production cost data for Ventura County crops (UCCES 1990) and organic costs of production budgets for the central coast (UCCES 1993).

TABLE 3-10

Crop Mix of Area Flooded, "With" and "Without" Reservoirs

| Crop | 100 yr Event With Reservoirs (acres) | 100 yr Event Without Reservoirs (acres) | Difference | | 25 yr Event With Reservoirs (acres) |
|-----------------|--------------------------------------------|--------------------------------------------------|------------|---------|-------------------------------------------|
| | | | Acres | Percent | |
| Pasture | 1,256 | 1,438 | 182 | 1.6% | 1,000 |
| Sugar Beet | 0 | 0 | 0 | 0.0% | 0 |
| Field Crop | 542 | 754 | 211 | 1.8% | 482 |
| Truck Crop | 27,601 | 38,226 | 10,622 | 92.3% | 12,826 |
| Orchard | 1 | 18 | 16 | 0.1% | 0 |
| Grain | 157 | 251 | 94 | 0.8% | 104 |
| Vineyard | 1,275 | 1,652 | 369 | 3.2% | 423 |
| TOTAL irrigated | 30,835 | 42,334 | 11,503 | | 14,385 |
| Other | 20,263 | 24,446 | 4,183 | | 18,586 |

Section 3 - Economic Benefit Analysis

The income lost for crops depends upon the area damaged and how long it takes to bring it back into production. Interviews with growers were the basis of estimates used in the analysis. In FSUs 1 through 3, 90 percent of the flooded land was damaged, and 95 percent was damaged in all other FSUs. Ten percent of the damaged land can be repaired in time for planting or replanting annual, cool season crops. This information was provided by a sample of growers based on their experiences with the 1995 floods. The 1995 flood in the Salinas Valley was slightly in excess of a 100-year flood event, but provides a representative basis for estimating damages that would occur during a 100-year event. No cost data were available for any crops except truck crops, so costs for other annual crops were developed using data provided by the CDFA and the USBR (1992). For vineyards and orchards, average damages from historical floods were used as reported to CDFA for these crop types.

Table 3-11 shows the losses per acre for cool season and perennial crops. For cool season crops already planted, there is an additional loss for the amount of money invested in the crop at the time of the flood. This cost is estimated to be \$100 per acre for grains and field crops and \$300 per acre for vegetables (truck crops). The amount of land planted at the time of flood was obtained from SVIGSM documentation (Montgomery Watson 1996) as the average percent land in rotation in December (10 percent) through March (60 percent).

The share of damaged land that cannot be repaired in time for summer crops was estimated from information provided by growers. This share, estimated to be 50 percent, incurs an additional loss calculated as gross income minus variable costs for each crop that would have been grown in the summer rotation. This cost

is \$1,000 per acre in FSUs 1 and 3; \$800 per acre for FSUs 2, 4, 5, and 6; \$600 per acre for FSUs 7, and 8A and 8B; and \$400 per acre for FSU 10. These costs are accounted for in column 4 ("Increased Income") in Table 3-15.

Agricultural Repair Costs

Agricultural repair costs are those incurred to return the land and its amenities to their pre-flood condition. Important repair costs in the Salinas Valley, based on information from the 1995 floods, include debris and sediment removal, grading, leveling, clearing of ponds and sediment basins, recovery or replacement of irrigation systems, repair or replacement of wells, and levee repairs.

Most damages from the 1995 floods were eligible for cost sharing by the Emergency Conservation Program (ECP). The ECP is administered by the U.S. Department of Agriculture (USDA). Data on all damages claimed were provided by the Farm Service Agency (FSA) office in Salinas (USDA FSA 1997). Farmers could claim compensation for four specific practices: debris removal (EC1); grading, shaping, or releveling (EC2); and underground pipeline replacement, dredging of ponds, and waste storage (EC3 and EC4). Data were provided by the USDA in the form of a farm identification number, the practice claimed, the amount paid, and the share of total costs paid by the government. The total cost for each practice was estimated from the cost share and the amount paid. About half of the data were used to create a sample, and subsamples of the data were checked to ensure that the total sample was representative.

Table 3-12 shows some characteristics of the data. Grading, shaping, or releveling accounted for much of the economic cost, and less than 1 percent of the acreage did

Section 3 - Economic Benefit Analysis

not report EC2. About 65 percent of the acreage did not report EC1. Figure 3-2 shows the cumulative distribution of EC2 costs per acre reporting. Average EC2 cost per acre reporting was \$509, and total average cost including EC1, EC2, EC3, and EC4 was \$627 per acre.

The ECP does not cover costs of fringe benefits, above-ground irrigation systems, well or levee repairs, or costs of other farm equipment (other than underground pipe) damaged or lost. Average irrigation system and well losses were obtained from growers and totaled \$99 per acre. Costs of levee repairs under Public Law 84-99 were estimated by the Corps to be about \$1.5 million (Wan 1997). With about 22,000 acres flooded the cost per acre was about \$68. It is believed that many individuals did not report their levee repair costs. To account for fringe benefits and other uncovered and uncounted costs, 20 percent of ECP costs were added to the total. On average, repair costs per damaged acre in the 1995 floods were estimated to be \$920.

These data were applied to the analysis as follows. Data for land acreage of low, medium, and high erosivity was delineated and classified in Section 2 of this report. It was assumed that land in the medium erosivity category would require the average cost per acre (\$920) to be restored to its pre-flood condition.

The additional acreage flooded in the "without reservoirs" condition is 20 percent of the total flooded acreage for the 100-year "without reservoirs" event. This acreage should have a lower-than-average repair cost because it represents land on the border of the floodplain where flow velocity, depth, and duration are less than average. From the 1995 ECP data, the average EC2 cost per acre for the lowest-cost 20 percent of acreage was \$116, as compared to the total average of \$509.

Expanding for all types of repair costs gives an average cost per acre of \$210 $((116/509)*920)$. This repair cost would be used as the average cost on low erosivity lands that are damaged, except that the percent increase in area flooded is different by FSU. Therefore, land repair cost per acre on additional lands flooded increases with the share these lands made up of all lands flooded.

Some land in FSUs 1, 7 and 9 is classified as highly in the without reservoirs case erodible. It is assumed that half of this land would be lost and half would pay the highest repair cost per acre. From Figure 3-2, \$2,000 is used as the repair cost. The value of land is estimated to be \$8,000 per acre in FSU 7; and \$4,000 per acre in FSU 9. Therefore, the costs per acre flooded are \$9,000 $((16,000 + 2,000)/2)$; \$5,000; and \$3,000, respectively. Land values were estimated from annual surveys published by California Farmer (Thompson 1997) and local sources.

Table 3-13 shows results in terms of additional acreage flooded in the 100-year floodplain, for without reservoirs conditions, by erosivity category and cost per acre by FSU. Most of the additional acreage flooded is in the low erosivity category. The average repair cost per acre of low erosivity additional land flooded differs by FSU, from a minimum of \$83 in ESU 1 to \$372 in FSU 3. Total cost per acre of additional land flooded varies from \$83 to \$471 per acre. Lowest costs per acre are in FSU 1 because less of the additional flooded land is damaged, and none of the additional land is classified as medium or highly erodible.

Section 3 - Economic Benefit Analysis

TABLE 3-11

Farm Income Losses on Additional Acreage Flood Damaged

(in dollars per acre)

| Crop | Gross Income | Variable Expense | Net Loss | Additional Loss if Planted at Flood | Share Planted at Flood |
|----------------------------|---------------------|------------------|----------|-------------------------------------|------------------------|
| Pasture (alfalfa) | \$649 | \$209 | \$440 | \$0 | 100% |
| Sugar beets | No acreage affected | | | | |
| Field crops | \$600 | \$200 | \$400 | \$100 | 30% |
| Truck crops ⁽²⁾ | \$4,428 | \$3,531 | \$1,037 | \$300 | 30% |
| Orchards ⁽³⁾ | | | \$4,753 | \$0 | 100% |
| Grain | \$350 | \$132 | \$218 | \$100 | 30% |
| Vineyards ⁽³⁾ | | | \$2,945 | \$0 | 100% |

NOTES:

1. Cool season and perennial crops only. See narrative for potential summer crop losses.
2. One-third each head lettuce, leaf lettuce, and cauliflower.
3. For orchards and vineyards, loss per acre from 1995 floods reported to CDFA. Assumes half damaged and half lost.

TABLE 3-12

1995 ECP Costs and Other Repair Costs Counted

| | Dollars Per Acre | |
|---------------------------------------|------------------|-------|
| EC1 cost per acre reporting | \$86 | |
| EC2 cost per acre reporting | \$509 | |
| EC3 and EC4 cost per acre | \$33 | |
| TOTAL | \$627 | |
| Percent of acres reporting EC2 | | 99.3% |
| Percent of acres reporting EC1 | | 35.0% |
| Cost for wells and irrigation systems | \$99 | |
| Cost for levee repairs, from Corps | \$68 | |
| Cost for frings and other, 20% of ECP | \$125 | |
| TOTAL AVERAGE COST PER ACRE | \$920 | |

Section 3 - Economic Benefit Analysis

TABLE 3-13

Erosivity and Repair Costs for Additional Acreage Flooded Without Reservoirs,
(100-Year Event)

| FSU | Total Additional Acres ¹ | Low Erosivity (Acres) | Medium Erosivity (Acres) | High Erosivity (Acres) | Share of Additional Acreage Damaged | Costs/Acre Flooded | | | Total Cost (in thousands of \$) | Average Cost Per Acre |
|-------|-------------------------------------|-----------------------|--------------------------|------------------------|-------------------------------------|--------------------|-------|---------|---------------------------------|-----------------------|
| | | | | | | Low ² | Med. | High | | |
| 1 | 2,335 | 2,335 | 0 | | 43.5% | \$83 | \$920 | \$9,000 | \$194 | \$83 |
| 2 | 95 | 95 | | | 90.0% | \$83 | \$920 | | \$8 | \$83 |
| 3 | 4,375 | 4,338 | 37 | | 83.4% | \$372 | \$920 | | \$1,649 | \$377 |
| 4 | | | | | | | | | | |
| 5 | 1,438 | 1,104 | 334 | | 76.1% | \$153 | \$920 | | \$476 | \$331 |
| 6 | | | | | | | | | | |
| 7 | 826 | 737 | 50 | 39 | 79.0% | \$198 | \$920 | \$5,000 | \$389 | \$471 |
| 8A | 57 | 57 | 0 | | 73.3% | \$143 | \$920 | | \$8 | \$143 |
| 8B | 429 | 402 | 28 | | 62.9% | \$104 | \$920 | | \$67 | \$156 |
| 9 | 1,496 | 1,378 | 110 | 9 | 81.6% | \$234 | \$920 | \$3,000 | \$449 | \$300 |
| 10 | 451 | 415 | 36 | | 78.2% | \$196 | \$920 | | \$115 | \$254 |
| Total | 11,503 | 10,855 | 600 | 48 | | | | | \$3,359 | |

NOTES:
1. From GIS
2. Product of share damaged and average cost per damaged acre given the percent increase in area flooded for that FSU.

The analysis counts additional damages on lands flooded even with the reservoirs because of increased velocity of water without the reservoirs. The physical data counts the change in the amount of land in the medium and high erosivity categories. The per-acre costs of these changes are merely the differences between the per acre costs established for each erosivity category for each FSU. In FSU 1 for example, the loss for land that increases from medium to high erosivity is \$8,080 (\$9,000 - \$920).

Results for the 100-year event are shown in Table 3-14. Dollar costs per acre are largest in FSUs 1 and 7, where some land changes from medium to high erosivity. Additional damages due to increased erosion without reservoirs for each acre that is flooded averages \$99.

Table 3-15 shows results of the analysis in terms of average annual acres flooded with reservoirs, additional acres flooded without reservoirs, and total economic benefits. Average annual acreage flooded can be calculated from inputs 1 through 4.

Section 3 - Economic Benefit Analysis

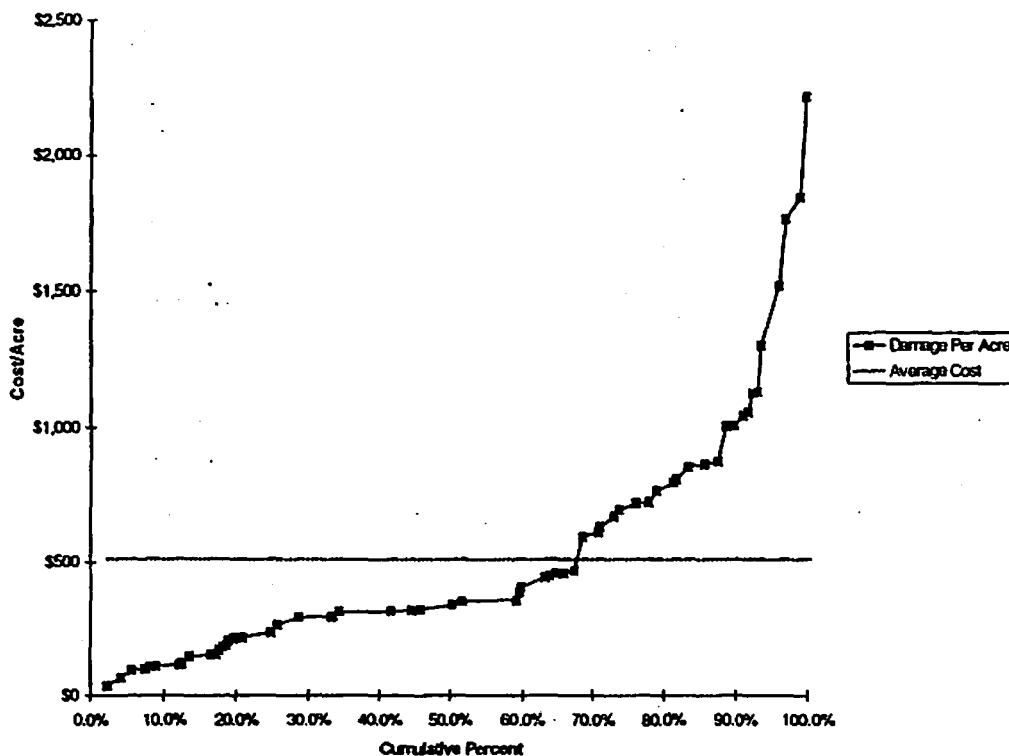

Figure 3-2
Cumulative Distribution of Costs Per Acre for EC2 Practices under the Emergency Conservation Program, 1995, Monterey County

Section 3 - Economic Benefit Analysis

TABLE 3-14
Increased Erosivity of Land in 100-Year Floodplain with Reservoirs and Associated Costs

| ESU | GIS: Acreage in 100-yr Floodplain | Acreage Changed from Low to Medium | | Acreage Changed from Med. to High | | Total Cost (in thousands of \$) | Total Cost/Acre |
|--------------|-----------------------------------------|---------------------------------------|---------|--------------------------------------|---------|---------------------------------------|--------------------|
| | | Acres | \$/Acre | Acres | \$/Acre | | |
| 1 | 10,867 | 1,017 | \$837 | 84 | \$8,080 | \$1,527 | \$140 |
| 2 | 0 | 0 | \$837 | 0 | 0 | 0 | 0 |
| 3 | 2,886 | 426 | \$547 | 0 | 0 | \$233 | \$81 |
| 4 | n/a | n/a | n/a | n/a | n/a | n/a | n/a |
| 5 | 5,430 | 346 | \$767 | 0 | 0 | \$266 | \$49 |
| 6 | n/a | n/a | n/a | n/a | n/a | n/a | n/a |
| 7 | 2,646 | 185 | \$722 | 113 | \$4,080 | \$593 | \$224 |
| 8A | 248 | 0 | \$777 | 0 | 0 | 0 | 0 |
| 8B | 2,756 | 253 | \$816 | 0 | 0 | \$208 | \$75 |
| 9 | 4,014 | 244 | \$686 | 0 | 0 | \$168 | \$42 |
| 10 | 1,515 | 24 | \$724 | 0 | 0 | \$18 | \$12 |
| 11 | n/a | n/a | n/a | n/a | n/a | n/a | n/a |
| Total | 30,327 | 2,496 | | 196 | | \$3,009 | |

Total benefits of the reservoirs over all regions are estimated to be about \$5.5 million on an annual average basis. Most of the benefits, about \$4.2 million, come from farm income. Reduced repair costs account for \$1.1 million, and reduced costs on lands flooded even with reservoirs account for \$200,000. FSUs 5 and 9 each account for just under one-quarter of the total benefit.

Prevention of Damages to Buildings and Structures

The second category of flood control benefits is the prevention of damages to buildings and structures. This section contains a description of the methodology used, the building inventory, and the benefits by FSU.

Methodology

The FEMA Riverine Benefit Cost Module (FEMA 1996) was used to estimate the flood control benefits of Nacimiento and San Antonio Reservoirs. FEMA uses this model to evaluate flood control projects submitted for funding under the Hazard Mitigation Grant Program (Section 404) and the Response and Recovery Program (Section 406) of the Stewart Act.

- Estimating flood control benefits using the FEMA Riverine Benefit Cost Model requires numerous data parameters. Because the FEMA model is a probabilistic-based procedure, the flood risk needs to be qualified. Traditional hydrology and hydraulic analytical procedures were used to estimate discharges and flood elevations for the 10-year, 50-year, 100-year, and 500-year frequency floods by reach for the "with" and "without reservoirs" conditions.

Section 3 - Economic Benefit Analysis

**TABLE 3-15
Economic Benefits from Prevention of Agricultural Damage by ESU**

| FSU # | (1) | (2) | (3)p | (4) | | (5) | (6) |
|----------------|-------------------------------------------------------|--------------------------------------------------------------------------|---------------------------------------------------------------------|---------------------------------------------------------------------|------------------|---------------------------------------------------|-----------------------------------------------------------|
| | Annual Avg Acres Flooded with Reservoirs ¹ | Avoided Erosivity Costs on These Acres ² (in thousands of \$) | Annual Additional Avg Acres Flooded Without Reservoirs ³ | Benefits for the Additional Acres ⁴ (in thousands of \$) | | Benefits per Additional Acre Flooded ⁵ | Total Economic Benefits ⁶ (in thousands of \$) |
| | | | | Avoided Repair Costs | Increased Income | | |
| 1 | 431 | \$60.6 | 895 | \$74 | \$637 | \$794 | \$771.6 |
| 2 | 12 | \$0.0 | 34 | \$3 | \$40 | \$1,269 | \$43.2 |
| 3 | 201 | \$16.3 | 369 | \$139 | \$472 | \$1,655 | \$627.2 |
| 5 | 720 | \$35.2 | 876 | \$290 | \$945 | \$1,409 | \$1,270.1 |
| 7 | 317 | \$71.1 | 440 | \$207 | \$456 | \$1,508 | \$734.6 |
| 8A | 18 | \$0.0 | 34 | \$5 | \$34 | \$1,137 | \$39.2 |
| 8B | 334 | \$25.0 | 475 | \$74 | \$403 | \$1,004 | \$502 |
| 9 | 257 | \$10.7 | 724 | \$217 | \$994 | \$1,674 | \$1,222.3 |
| 10 | 61 | \$0.7 | 283 | \$72 | \$227 | \$1,056 | \$299.5 |
| TOTAL | 2,346 | \$218.6 | 4,124 | \$1,084.2 | \$4,208.1 | | \$5,510.9 |
| \$/acre | | \$93.2 | | \$262.9 | \$1,020.3 | | |

1. Average is weighted by probability of flooding with reservoirs.
2. Column 1 multiplied by costs per acre from Table 3-14.
3. Average is weighted by probability of flooding without reservoirs.
4. Avoided repair costs equal to column 3 multiplied by average costs per acre from Table 3-13. Increased income equals column 3 multiplied by average net income 1055 of mix of crops in FSU.
5. Column 5 equals the sum of avoided repair costs and increased net income from Column 4 divided by the acreage of Column 3.
6. Column 6 = Col2 + Col. 4.

The resulting elevations are shown in Appendix C, Table C-7.

Further information on the methodology used to estimate flood control benefits from the prevention of damages to buildings and structures is presented in Appendix C.

Building Inventory

The number, location, and size of buildings and structures lying within the

100-year floodplain without the reservoirs were estimated using USGS quadrangle maps of the valley and visual inspection. The 100-year floodplain without reservoirs represents the area being protected by the flood control project. A total of 1,118 buildings and structures were identified as being located in the study area (Table 3-16). Total flood area of the buildings is more than 2 million square feet.

Section 3 - Economic Benefit Analysis

Table 3-16
Buildings and Structures Located in 100-year
Without Reservoir Flood Plain, Salinas Valley

| Flood Study Unit | | |
|-------------------------------------------|--------------|------------------|
| Description | Number | Sum of Area |
| FSU 1 | | |
| Auto repair | 2 | 3,000 |
| Business (general) | 2 | 5,000 |
| Farm Shop/Storage | 11 | 59,600 |
| Furniture | 1 | 3,000 |
| Greenhouse | 1 | 190,000 |
| Grocery store | 1 | 2,000 |
| Industrial, Light | 2 | 15,000 |
| Motel | 1 | 5,000 |
| Office building | 1 | 2,000 |
| Primary Sewage Treatment Plant | 6 | 12,000 |
| Public Office Bldg | 1 | 4,000 |
| Public Recycle Bldg | 1 | 1,000 |
| Public Recycle Lot | 1 | 5,000 |
| Residence, 1 story w/o basement | 326 | 332,700 |
| Residence, 2 story w/o basement | 39 | 76,000 |
| Residence, Apartment w/garden level units | 6 | 13,750 |
| Residence, Mobile Home | 19 | 7,600 |
| Restaurant | 3 | 5,000 |
| Storage | 1 | 25,000 |
| Telephone Repair Shop | 1 | 2,500 |
| FSU 1 Totals | 426 | 769,150 |
| FSU 3 | | |
| Industrial, Light | 8 | 440,000 |
| Primary Sewage Treatment Plant | 1 | 10,000 |
| Residence, 1 story w/o basement | 405 | 405,000 |
| Residence, 2 story w/o basement | 120 | 240,000 |
| School | 4 | 26,000 |
| FSU 3 Totals | 538 | 1,121,000 |
| FSU 5 | | |
| Ag Infrastructure | 1 | 1 |
| Farm Shop/Storage | 1 | 10,000 |
| Residence, 1 story w/o basement | 112 | 112,000 |
| Residence, 2 story w/o basement | 11 | 22,000 |
| FSU 5 Totals | 125 | 144,001 |
| FSU 7 | | |
| Residence, 1 story w/o basement | 9 | 9,000 |
| Residence, 2 story w/o basement | 3 | 6,000 |
| FSU 7 Totals | 12 | 15,000 |
| FSU 8A | | |
| (none) | | |
| FSU 8B | | |
| Farm Shop/Storage | 4 | 5,500 |
| Residence, 1 story w/o basement | 2 | 4,500 |
| Residence, 2 story w/o basement | 1 | 2,500 |
| FSU 8 Totals | 7 | 12,500 |
| FSU 9 | | |
| Farm Shop/Storage | 2 | 11,500 |
| Residence, 1 story w/o basement | 1 | 2,000 |
| Residence, 2 story w/o basement | 1 | 1,000 |
| FSU 9 Totals | 4 | 14,500 |
| FSU 10 | | |
| Farm Shop/Storage | 4 | 25,500 |
| Residence, 2 story w/o basement | 2 | 4,300 |
| FSU 10 Totals | 6 | 29,800 |
| Salinas Valley Totals | 1,118 | 2,105,951 |

Section 3 - Economic Benefit Analysis

Almost half of the total buildings are located in FSU 3, and 97 percent of those are residential structures located mostly in the City of Salinas and the town of Spreckels. The industrial area of Spreckels comprises about 440,000 square feet of floor space.

The City of Castroville is located in FSU 1 and a substantial portion of the residential, industrial and business buildings are located within the 100-year floodplain without the reservoirs. Most of these buildings were flooded during the 1995 floods. A recently constructed greenhouse of approximately 190,000 square feet is located in the floodplain adjacent to Castroville.

The remaining buildings inventoried are located in FSUs 5, 7, 8A, 8B, 9, and 10, with only 29 buildings located in the FSUs 7 through 10. FSU 2 is located in the extreme northeast portion of the valley, and most of the area within the floodplain serves as seasonal rain and irrigation drainage channels and it is not used for buildings or structures.

Flood Control Benefits to Buildings and Structures

Flood control benefits are estimated by subtracting the expected annual damages and losses with the reservoirs from the expected annual damages and losses without the reservoirs.

Expected annual damages and losses without the reservoirs are estimated at \$5.7 million (Table 3-17). About 80 percent of this amount represents physical damages. Contents damage is double the estimated structural damage, which is common when a substantial amount of the buildings are used for industrial and processing uses. Relocation costs comprise almost 20 percent of the total

damages and losses. Income and public service losses are less than 1 percent of the total damages and losses.

FSU 1 has large expected annual damages and losses relative to FSU 3 even though FSU 3 has more buildings and floor area. FSU 1 is situated in the lower elevations of the valley and subject to greater flood damages.

Expected annual damages and losses with the reservoirs are estimated at \$1.2 million (Table 3-18). This represents more than a 77 percent reduction in damages and losses. As expected, FSU 1 is the largest beneficiary of flood control with respect to preventing damages and losses to buildings and structures. Because a flood control project restricts high water flows, it will be the most effective in preventing damages and losses in the lower elevations of the valley.

Table 3-19 summarizes the annual benefits accrued from protecting buildings and structures. These economic benefits are calculated by subtracting the damages and lost incomes and services "with" the reservoirs (Table 3-18) from those "without" reservoirs (Table 3-17).

OTHER UNQUANTIFIED BENEFITS OF THE RESERVOIRS

The Historical Benefits Analysis estimates annual benefits produced by the existence of the reservoirs given their historical operation. This report quantifies only those benefits for which information exists or can reasonably be estimated. Additional benefits may occur from the reservoirs that have not yet been captured by water users or cannot be easily quantified.

Ground water can be valued both as a resource stock (or inventory) and as a flow of benefits to users of the resource.

Section 3 - Economic Benefit Analysis

**Table 3-17
Damages and Lost Incomes and Services Without Reservoirs, Salinas Valley**

| FSU | Damages | | Relocation Costs | Value of Lost Services | Lost Net Income | Totals |
|---------------|--------------------|--------------------|--------------------|------------------------|-----------------|--------------------|
| | Building | Contents | | | | |
| 1 | \$937,100 | \$1,939,585 | \$687,989 | \$1,276 | \$7,704 | \$3,573,654 |
| 2 | \$0 | \$0 | \$0 | \$0 | \$0 | \$0 |
| 3 | \$432,829 | \$1,123,030 | \$387,862 | \$13,797 | \$4,149 | \$1,961,668 |
| 4 | N/A | N/A | N/A | N/A | N/A | N/A |
| 5 | \$73,763 | \$37,938 | \$29,805 | \$0 | \$0 | \$141,505 |
| 6 | N/A | N/A | N/A | N/A | N/A | N/A |
| 7 | \$1,556 | \$801 | \$743 | \$0 | \$0 | \$3,101 |
| 8A | \$0 | \$0 | \$0 | \$0 | \$0 | \$0 |
| 8B | \$832 | \$2,785 | \$754 | \$0 | \$7 | \$4,378 |
| 9 | \$907 | \$4,449 | \$798 | \$0 | \$12 | \$6,165 |
| 10 | \$2,225 | \$16,071 | \$2,737 | \$0 | \$43 | \$21,076 |
| 11 | N/A | N/A | N/A | N/A | N/A | N/A |
| Totals | \$1,449,212 | \$3,124,660 | \$1,110,688 | \$15,073 | \$11,915 | \$5,711,547 |

**Table 3-18
Damages and Lost Incomes and Services With Reservoirs, Salinas Valley**

| ESU | Damages | | Relocation Costs | Value of Lost Services | Lost Net Income | Totals |
|---------------|------------------|------------------|------------------|------------------------|-----------------|--------------------|
| | Building | Contents | | | | |
| 1 | \$145,090 | \$217,840 | \$83,622 | \$306 | \$988 | \$447,845 |
| 2 | \$0 | \$0 | \$0 | \$0 | \$0 | \$0 |
| 3 | \$203,738 | \$385,300 | \$141,508 | \$4,021 | \$1,245 | \$735,812 |
| 4 | N/A | N/A | N/A | N/A | N/A | N/A |
| 5 | \$19,127 | \$9,006 | \$7,457 | \$0 | \$0 | \$35,590 |
| 6 | N/A | N/A | N/A | N/A | N/A | N/A |
| 7 | \$10 | \$5 | \$4 | \$0 | \$0 | \$20 |
| 8A | \$0 | \$0 | \$0 | \$0 | \$0 | \$0 |
| 8B | \$595 | \$2,159 | \$578 | \$0 | \$5 | \$3,338 |
| 9 | \$222 | \$1,014 | \$178 | \$0 | \$3 | \$1,417 |
| 10 | \$1,308 | \$8,878 | \$1,460 | \$0 | \$24 | \$11,669 |
| 11 | N/A | N/A | N/A | N/A | N/A | N/A |
| Totals | \$370,091 | \$624,202 | \$234,806 | \$4,326 | \$2,264 | \$1,235,689 |

**Table 3-19
Economic Benefits of Flood Control for Buildings and Structures, Salinas Valley**

| FSU | Damages | | Relocation Costs | Value of Lost Services | Lost Net Income | Total Benefits |
|---------------|--------------------|--------------------|------------------|------------------------|-----------------|--------------------|
| | Building | Contents | | | | |
| 1 | \$792,010 | \$1,721,745 | \$604,367 | \$970 | \$6,716 | \$3,125,809 |
| 2 | \$0 | \$0 | \$0 | \$0 | \$0 | \$0 |
| 3 | \$229,091 | \$737,730 | \$246,355 | \$9,776 | \$2,905 | \$1,225,857 |
| 4 | N/A | N/A | N/A | N/A | N/A | N/A |
| 5 | \$54,636 | \$28,932 | \$22,348 | \$0 | \$0 | \$105,916 |
| 6 | N/A | N/A | N/A | N/A | N/A | N/A |
| 7 | \$1,546 | \$798 | \$739 | \$0 | \$0 | \$3,081 |
| 8A | \$0 | \$0 | \$0 | \$0 | \$0 | \$0 |
| 8B | \$237 | \$626 | \$176 | \$0 | \$1 | \$1,040 |
| 9 | \$684 | \$3,435 | \$620 | \$0 | \$9 | \$4,749 |
| 10 | \$917 | \$7,193 | \$1,277 | \$0 | \$19 | \$9,407 |
| 11 | N/A | N/A | N/A | N/A | N/A | N/A |
| Totals | \$1,073,121 | \$2,500,458 | \$875,882 | \$10,747 | \$9,650 | \$4,475,858 |

Over time, the inventory value becomes converted to a flow value as the resource is used, although it also can be partly or fully renewed. When valuing the ground water resource it is important not to double count by adding the flow and the stock value. The approach of the HBA has been to estimate the annual flow of benefits associated with ground water conditions with and without the reservoirs.

Ground Water Quality Benefits Outside the Intrusion Area

Two components of ground water quality effects are possible. The avoided cost in the seawater intrusion area has been estimated as described above. In other parts of the valley, potential improvements in ground water quality due to operation of the reservoirs are more difficult to assess. Because the ground water model used for the HBA does not yet have the capability to simulate movement of water quality constituents, the economic benefits of this component cannot be quantified.

Value of Good Quality Ground Water in Storage

An increase in stored ground water provides annual benefits to water users in the form of avoided pumping and well costs, as estimated above. However, the reservoirs have created a ground water condition that is better than the "without reservoirs" condition. Some benefit of this condition will be captured by water users in the future, in the form of lower pumping costs. Part of the benefit of current operation of the reservoirs carries over into future years, and will continue to do so even after the reservoirs' useful operational life is over. Therefore, ending the Historical Benefits Analysis at any point in time fails to account for this

future value. For purposes of comparing annual benefit to an annual assessment, this approach is appropriate, because over time all of the benefits are realized. If the Historical Benefits Analysis is updated next year, some of this year's carryover benefit would be captured in the analysis, and some benefits will continue to be realized long after the reservoirs are no longer operational.

In addition, the reservoir operations will extend the useful life of the ground water aquifer. At some future time, fresh water may no longer be found by drilling deeper, and that time is more distant with the reservoirs than without. The present value of this difference has not been quantified in this analysis, but is believed to be small.

Value of the Ground Water Basin for Storage and Distribution

If seawater intrudes into an aquifer, that portion of the aquifer is lost from future use as a storage reservoir and as a way to distribute stream recharge. One approach to estimating the cost of seawater intrusion is to calculate the cost of replacing this storage and distribution system with a surface system. This approach is an alternative to the approach we have taken in this report, which is to calculate the avoided cost of drilling deeper wells. When water users are facing the loss of a usable aquifer to intrusion, two response options are to abandon the ground water and construct a surface water system, or to drill new wells to tap a deeper aquifer. Water users would not do both concurrently. To calculate the cost avoided of both approaches and add them together would double count the benefit of reduced intrusion. Building a surface storage and distribution system is a higher-cost

Section 3 - Economic Benefit Analysis

alternative approach to the one we have chosen in this analysis.

Value of the Reservoirs as Insurance against Rainfall Variation

An important purpose of reservoirs in California is to moderate and reduce the variation in water supply over the years. The Historical Benefits Analysis conducted using the SVIGSM has estimated the historical sequence of water availability with and without the reservoirs. It therefore provides a retrospective numerical description of the difference in water supply variability with and without the reservoirs. The analysis does not capture the additional value of avoiding future risk. Water users are generally willing to pay something to avoid risk, a value economists call the risk premium. The magnitude of the risk premium depends on how much the variability of supply is altered by the dams and on the water users' risk preferences (how averse to risk they are and therefore how much they are willing to pay to avoid it). Risk preferences have not been estimated in this study, so the value of avoiding future risk is acknowledged but not quantified.

Recreation and Environmental Benefits

Nacimiento and San Antonio Reservoirs provide opportunities for boating, fishing, and general recreation. Economic benefits as a result of these recreational opportunities accrue to local business as well as recreationists. The reservoirs also provide a variety of environmental benefits by enhancing the habitat for fish, wildlife, and vegetative species. The distribution of these recreational and environmental benefits, however, are not restricted to any specific ESU, but can be spread equally throughout the Valley. Therefore, recreational and environmental

benefits are not quantified in the HBA because they are equal for all ESUs.

Other Indirect Benefits

The construction and operation of Nacimiento and San Antonio Reservoirs has brought about indirectly, other intangible benefits to the agricultural and urban economy of Salinas Valley. Included are increased land values, employment opportunities, and tourism.

Section 4



MONTGOMERY WATSON

AR 07144

Section 4

References

References

California Department of Food and Agriculture, 1997. Summary of January Rain/Flood Damage by Commodity.

Durbin, et. al. Two Dimensional and Three Dimensional Digital Flow Models for the Salinas Valley Ground Water Basin, California, November 1978.

Economic and Environmental Principles and Guidelines for Water and Related Land Resources Implementation Studies, 1983, U.S. Water Resources Council.

Monterey County Agricultural Commissioners Office, 1985-1995. Monterey County Annual Crop Reports.

Montgomery Watson, 1996. Table 2-3. Monthly Estimates of Truck Crop Acreage that are "In-Between Rotation."

Montgomery Watson. Salinas River Basin Water Resources Management Plan, Task 1.09 Report. Salinas, 1994.

Montgomery Watson. Salinas Valley Integrated Ground Water and Surface Water Model Update, May 1997.

Staal, Gardner and Dunne, Inc. Hydrogeologic Investigation Arroyo Seco Cone. Salinas, 1994.

Thompson, Kevin. 1997. Terra Firma. California Farmer, 280(6) Mid-March 1997, Page 8.

United States Department of Agriculture, Farm Service Agency, Monterey-Santa Cruz-San Mateo. Table 4C- CRES Detail Table, Salinas.

United States Department of the Interior, Bureau of Reclamation, 1992. CVP Allocation Study Payment Capacity Appendix 3. Addendum 3 & 4. Mid Pacific Region, Sacramento.

United States Geological Survey, 1974. Geology of the Southern Salinas Valley Area. Washington.

United States Geological Survey, 1986. A Water Resources Data Network Evaluation for Monterey County. Sacramento.

University of California Cooperative Extension Service, 1992. Monterey County Lettuce Production Costs 1992. Salinas.

U. California Cooperative Extension Service, 1990. Costs and Practices in Ventura County for Lima Beans and Vegetables. U. California Cooperative Extension, Ventura, CA.

Section 4 - References

U. California Cooperative Extension Service, 1993. Production Practices and Sample Costs for a Diversified Organic Vegetable Operation in the Central Coast. U. California Davis

Wan, Sing, 1997. U.S. Army Corps of Engineers. Personal Communication. San Francisco.

Section 5



MONTGOMERY WATSON

AR 07147

Section 5

Glossary of Terms

100-year flood. A 100 year flood is that which has a possibility of occurrence of 1 percent, i.e., there is a 1 percent chance each year that this magnitude of flood will occur.

Acre-foot. The quantity of water required to cover 1 acre to a depth of 1 foot. Equal to 1,233.5 cubic meters (43,560 cubic feet).

Alluvium. A general term for clay, silt, sand, gravel, or similar unconsolidated material deposited during comparatively recent geologic time by a stream or other body of running water as a sorted or semi-sorted sediment in the bed of the stream or on its floodplain or delta, or as a cone or fan at the base of a mountain slope.

Applied water. The quantity of water that is supplied to agricultural fields to meet irrigation water requirements delivered to the intake to a city's water system and the farm headgate, the amount of water supplied to a marsh or other wetland, either directly or by incidental drainage flows.

Aquiclude. A saturated, but poorly permeable bed, formation, or group of formations that does not yield water freely to a well or spring. However, an aquiclude may transmit appreciable water to or from adjacent aquifers.

Aquifer. A formation, group of formations, or part of a formation that contains sufficient saturated formations to alter the formation physically to improve its hydraulic properties.

Boundary flows. Defined in SVIGSM as subsurface flow entering the main ground water basin from the surrounding watersheds.

Drawdown. The distance between the static water level and the surface of the cone of depression.

Electrical Conductivity. A measure of the ability of a solution to conduct an electrical current which, in the case of water, can be related to the concentration of dissolved solids.

Erosivity. The susceptibility of an area to loss of land or soil cover due to scouring by water.

Erosivity index. In this study, a qualitative and relative measure of the susceptibility of an area to loss of land or soil cover due to scouring by water.

Exceedence (probability). The statistical likelihood that a particular value will be exceeded.

Floodplain. The surface of strip of land adjacent to a river channel, constructed by the present river and covered with water when the river overflows its banks.

Hydraulic gradient. The rate of change in total hydraulic head per unit of distance of flow in a given direction.

Minimum pool. The minimum storage below which the reservoir is not typically operated.

Overbank. The area outside the river channel, where flood damage typically occurs.

Overbank velocity. The velocity of flood flows in areas outside of the river channel.

Percolation. The act of water seeping or filtering through the soil without a definite channel.

Permeability. The property or capacity of a porous rock, sediment, or soil for transmitting a fluid; it is a measure of the relative ease of fluid flow under unequal pressure.

Pump bowl. The impeller housing assembly in vertical turbine pumps.

Recharge. The addition of water to the zone of saturation; also, the amount of water added.

Roughness. The surface characteristics of the stream channel which affect flow within the channel.

Runoff. The component of flow over the land surface as a result of precipitation.

Scenario damages. The expected damages per flood of a given flood depth at a building or structure.

Seawater intrusion. The phenomenon occurring when a body of seawater invades a body of fresh water. It can occur either in surface or ground water bodies, but is limited to the invasion of ground water in the focus of this report.

Siltation/Sedimentation. The deposition of material carried by water from one area to another.

Subsurface flow. Flow of ground water through aquifers.

Section 5 - Glossary of Terms

Total dissolved solids. The dissolved mineral constituents in water, usually stated in parts per million by weight. The measure of all salts in solution.

µmhos/cm (micromhos/centimeter). A typical measurement unit of electrical conductance which provides a measure of the total dissolved solids.

Unconfined aquifer. An aquifer where the water table is exposed to the atmosphere through openings in the overlying materials.

Unit hydrograph. The response in runoff of a watershed to a unit precipitation.

Water year. Usually when related to hydrology, the period of time beginning October 1 of one year and ending September 30 of the following year and designated by the calendar year in which it ends.

Well perforations. The screened interval in a well casing which provides an opening for ground water intake into the well.

Section 6



MONTGOMERY WATSON

AR 07151

Section 6 Project Team

MONTEREY COUNTY WATER RESOURCES AGENCY

Gene Taylor, Senior Hydrologist
Howard Franklin, Hydrologist
Germán Criollo, Water Conservation Technician
Robert Johnson, Senior Hydrologist
Darryl Tyler, GIS Technician
Dennis Lebow, Hydrologist
Owen Stewart, Associate Water Resources Engineer
Dr. U Win, Principal Hydrologist
Margo Nottenkamper, AICP, Planning Services & Water Conservation Manager
Jan Sweigert, Hydrology Technician

MONTGOMERY WATSON

Lyndel Melton, Principal-In-Charge
Dr. S. Ali Taghavi, Project Manager
Derrick Wong, Project Engineer

CH2M HILL

Allan Highstreet, Project Senior Economist
Steve Hatchett, Project Senior Economist
Bin Zhang, Project Economist
Roger Mann, Project Economist

Jerry Horner, Hazard Mitigation Economics

SCHAAF & WHEELER

James Schaaf, Principal
Kate True, Associate Engineer
Kevin Booker, Jr. Engineer
Mike McGovern, Jr. Engineer
Michele Mogel, Jr. Engineer
Adam Lee, Student
Heather Lindsey, Student