

Appendix E
Traffic Count Data

Hwy 1 Carmel Valley Rd



Peak Hour

Date: 05/25/2017
Count Period: 7:00 AM to 9:00 AM
Peak Hour: 7:30 AM to 8:30 AM

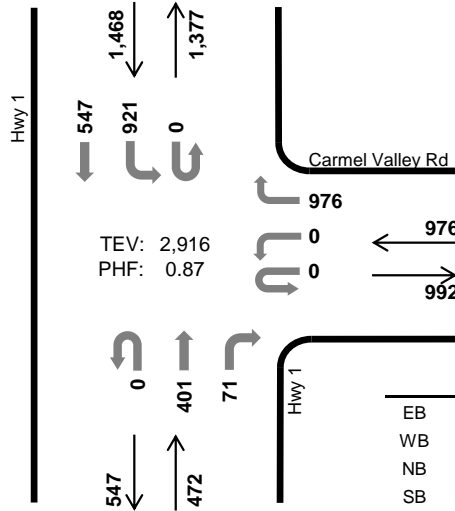

TEV: 2,916
PHF: 0.87

	HV %:	PHF
EB	-	-
WB	1.5%	0.76
NB	3.0%	0.80
SB	3.6%	0.92
TOTAL	2.8%	0.87

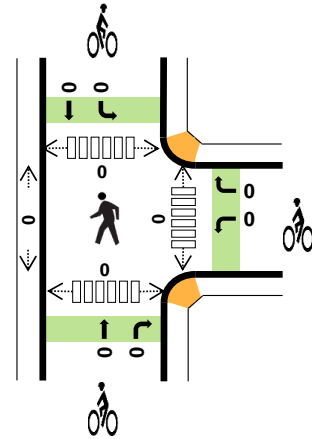

Two-Hour Count Summaries

Interval Start	0				Carmel Valley Rd				Hwy 1				Hwy 1			15-min Total	Rolling One Hour		
	Eastbound				Westbound				Northbound				Southbound						
	UT	LT	TH	RT	UT	LT	TH	RT	UT	LT	TH	RT	UT	LT	TH	RT			
7:00 AM	0	0	0	0	0	0	0	119	0	0	46	5	0	133	92	0	395	0	
7:15 AM	0	0	0	0	0	0	0	213	0	0	72	20	0	222	97	0	624	0	
7:30 AM	0	0	0	0	0	0	0	321	0	0	89	29	0	276	125	0	840	0	
7:45 AM	0	0	0	0	0	0	0	215	0	0	89	20	0	236	131	0	691	2,550	
8:00 AM	0	0	0	0	0	0	0	225	0	0	91	7	0	213	144	0	680	2,835	
8:15 AM	0	0	0	0	0	0	0	215	0	0	132	15	0	196	147	0	705	2,916	
8:30 AM	0	0	0	0	0	0	0	166	0	0	107	22	0	221	161	0	677	2,753	
8:45 AM	0	0	0	0	0	0	0	200	0	0	102	18	0	239	144	0	703	2,765	
Count Total	0	0	0	0	0	0	0	1,674	0	0	728	136	0	1,736	1,041	0	5,315	0	
Peak Hour	All	0	0	0	0	0	0	0	976	0	0	401	71	0	921	547	0	2,916	0
	HV	0	0	0	0	0	0	0	15	0	0	12	2	0	26	27	0	82	0
	HV%	-	-	-	-	-	-	-	2%	-	-	3%	3%	-	3%	5%	-	3%	0

Note: Two-hour count summary volumes include heavy vehicles but exclude bicycles in overall count.

Interval Start	Heavy Vehicle Totals					Bicycles					Pedestrians (Crossing Leg)				
	EB	WB	NB	SB	Total	EB	WB	NB	SB	Total	East	West	North	South	Total
7:00 AM	0	4	2	5	11	0	0	0	0	0	0	0	0	0	0
7:15 AM	0	6	5	12	23	0	0	0	0	0	0	0	0	0	0
7:30 AM	0	2	6	10	18	0	0	0	0	0	0	0	0	0	0
7:45 AM	0	1	2	10	13	0	0	0	0	0	0	0	0	0	0
8:00 AM	0	7	2	12	21	0	0	0	0	0	0	0	0	0	0
8:15 AM	0	5	4	21	30	0	0	0	0	0	0	0	0	0	0
8:30 AM	0	3	7	19	29	0	1	0	0	1	0	0	0	0	0
8:45 AM	0	2	4	15	21	0	0	0	0	0	0	0	0	0	0
Count Total	0	30	32	104	166	0	1	0	0	1	0	0	0	0	0
Peak Hr	0	15	14	53	82	0	0	0	0	0	0	0	0	0	0

Hwy 1 Carmel Valley Rd



Peak Hour

Date: 05/25/2017
Count Period: 4:00 PM to 6:00 PM
Peak Hour: 4:00 PM to 5:00 PM

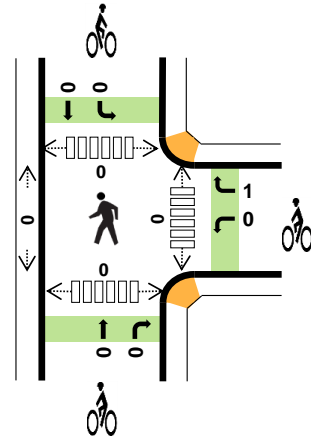
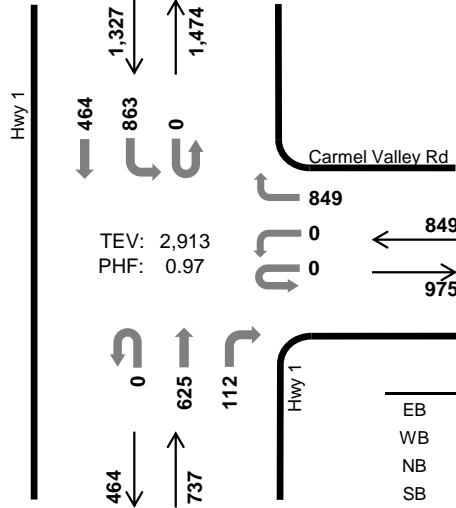

	HV %:	PHF
EB	-	-
WB	0.6%	0.90
NB	3.3%	0.89
SB	1.6%	0.95
TOTAL	1.7%	0.97

Two-Hour Count Summaries

Interval Start	0				Carmel Valley Rd				Hwy 1				Hwy 1				15-min Total	Rolling One Hour	
	Eastbound				Westbound				Northbound				Southbound						
	UT	LT	TH	RT	UT	LT	TH	RT	UT	LT	TH	RT	UT	LT	TH	RT			
4:00 PM	0	0	0	0	0	0	0	235	0	0	146	23	0	215	133	0	752	0	
4:15 PM	0	0	0	0	0	0	0	200	0	0	150	23	0	224	106	0	703	0	
4:30 PM	0	0	0	0	0	0	0	219	0	0	169	39	0	196	112	0	735	0	
4:45 PM	0	0	0	0	0	0	0	195	0	0	160	27	0	228	113	0	723	2,913	
5:00 PM	0	0	0	0	0	0	0	245	0	0	175	16	0	189	106	0	731	2,892	
5:15 PM	0	0	0	0	0	0	0	214	0	0	125	19	0	236	106	0	700	2,889	
5:30 PM	0	0	0	0	0	0	0	175	0	0	151	24	0	192	97	0	639	2,793	
5:45 PM	0	0	0	0	0	0	0	178	0	0	165	24	0	168	103	0	638	2,708	
Count Total	0	0	0	0	0	0	0	1,661	0	0	1,241	195	0	1,648	876	0	5,621	0	
Peak Hour	All	0	0	0	0	0	0	0	849	0	0	625	112	0	863	464	0	2,913	0
	HV	0	0	0	0	0	0	0	5	0	0	18	6	0	17	4	0	50	0
	HV%	-	-	-	-	-	-	-	1%	-	-	3%	5%	-	2%	1%	-	2%	0

Note: Two-hour count summary volumes include heavy vehicles but exclude bicycles in overall count.

Interval Start	Heavy Vehicle Totals					Bicycles					Pedestrians (Crossing Leg)				
	EB	WB	NB	SB	Total	EB	WB	NB	SB	Total	East	West	North	South	Total
4:00 PM	0	2	7	7	16	0	1	0	0	1	0	0	0	0	0
4:15 PM	0	1	7	6	14	0	0	0	0	0	0	0	0	0	0
4:30 PM	0	1	6	4	11	0	0	0	0	0	0	0	0	0	0
4:45 PM	0	1	4	4	9	0	0	0	0	0	0	0	0	0	0
5:00 PM	0	2	2	5	9	0	0	0	0	0	0	0	0	0	0
5:15 PM	0	2	4	3	9	0	0	0	0	0	0	0	0	0	0
5:30 PM	0	2	2	8	12	0	0	0	0	0	0	0	0	0	0
5:45 PM	0	3	1	4	8	0	0	0	0	0	0	0	0	0	0
Count Total	0	14	33	41	88	0	1	0	0	1	0	0	0	0	0
Peak Hr	0	5	24	21	50	0	1	0	0	1	0	0	0	0	0

Carmel Rancho Blvd Carmel Valley Rd



Date: 05/25/2017
Count Period: 7:00 AM to 9:00 AM
Peak Hour: 7:15 AM to 8:15 AM

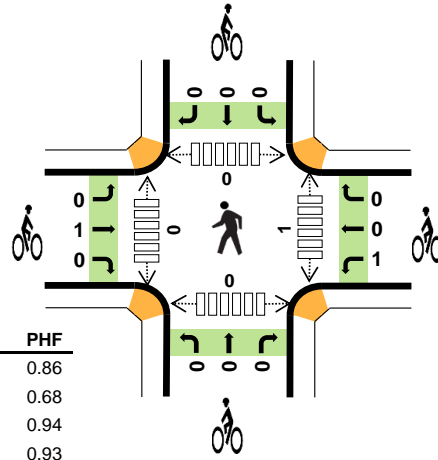
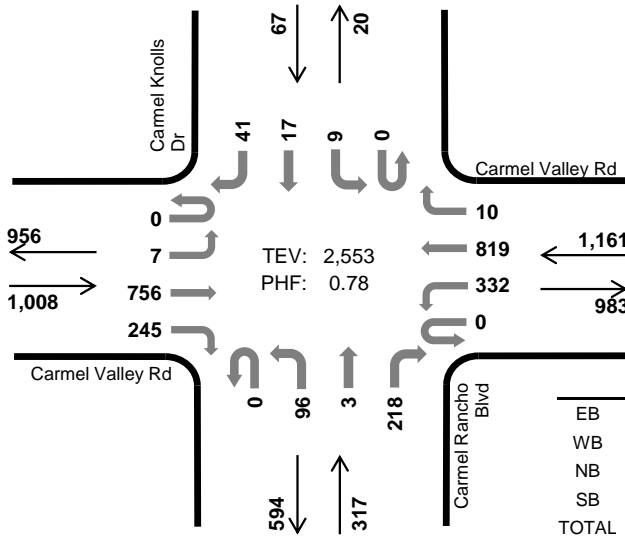

	HV %:	PHF
EB	2.2%	0.86
WB	1.8%	0.68
NB	2.2%	0.94
SB	4.5%	0.93
TOTAL	2.1%	0.78

Two-Hour Count Summaries

Interval Start	Carmel Valley Rd Eastbound				Carmel Valley Rd Westbound				Carmel Rancho Blvd Northbound				Carmel Knolls Dr Southbound				15-min Total	Rolling One Hour	
	UT	LT	TH	RT	UT	LT	TH	RT	UT	LT	TH	RT	UT	LT	TH	RT			
7:00 AM	0	2	97	40	0	36	104	0	0	13	0	18	0	0	0	5	315	0	
7:15 AM	0	1	175	50	0	63	176	0	0	18	0	61	0	1	3	14	562	0	
7:30 AM	0	1	226	66	0	134	285	7	0	19	0	65	0	7	2	8	820	0	
7:45 AM	0	2	199	64	0	62	185	1	0	31	0	51	0	1	6	7	609	2,306	
8:00 AM	0	3	156	65	0	73	173	2	0	28	3	41	0	0	6	12	562	2,553	
8:15 AM	0	6	130	61	0	86	165	0	0	35	1	40	0	1	6	12	543	2,534	
8:30 AM	0	5	144	95	0	81	149	1	0	23	3	52	0	2	3	8	566	2,280	
8:45 AM	0	2	142	101	0	110	162	0	0	21	1	54	0	4	1	5	603	2,274	
Count Total	0	22	1,269	542	0	645	1,399	11	0	188	8	382	0	16	27	71	4,580	0	
Peak Hour	All	0	7	756	245	0	332	819	10	0	96	3	218	0	9	17	41	2,553	0
	HV	0	0	17	5	0	5	15	1	0	1	0	6	0	2	0	1	53	0
	HV%	-	0%	2%	2%	-	2%	2%	10%	-	1%	0%	3%	-	22%	0%	2%	2%	0

Note: Two-hour count summary volumes include heavy vehicles but exclude bicycles in overall count.

Interval Start	Heavy Vehicle Totals					Bicycles					Pedestrians (Crossing Leg)				
	EB	WB	NB	SB	Total	EB	WB	NB	SB	Total	East	West	North	South	Total
7:00 AM	1	2	2	0	5	0	0	0	0	0	1	0	0	0	1
7:15 AM	8	5	1	1	15	0	0	0	0	0	0	0	0	0	0
7:30 AM	6	3	1	1	11	1	1	0	0	2	0	0	0	0	0
7:45 AM	3	4	2	0	9	0	0	0	0	0	0	0	0	0	0
8:00 AM	5	9	3	1	18	0	0	0	0	0	1	0	0	0	1
8:15 AM	12	3	6	0	21	0	0	0	0	0	2	0	1	1	4
8:30 AM	10	4	2	0	16	0	1	0	0	1	1	0	0	0	1
8:45 AM	11	2	3	0	16	0	0	0	0	0	1	0	0	0	1
Count Total	56	32	20	3	111	1	2	0	0	3	6	0	1	1	8
Peak Hour	22	21	7	3	53	1	1	0	0	2	1	0	0	0	1

Carmel Rancho Blvd Carmel Valley Rd



Date: 05/25/2017
Count Period: 4:00 PM to 6:00 PM
Peak Hour: 4:00 PM to 5:00 PM

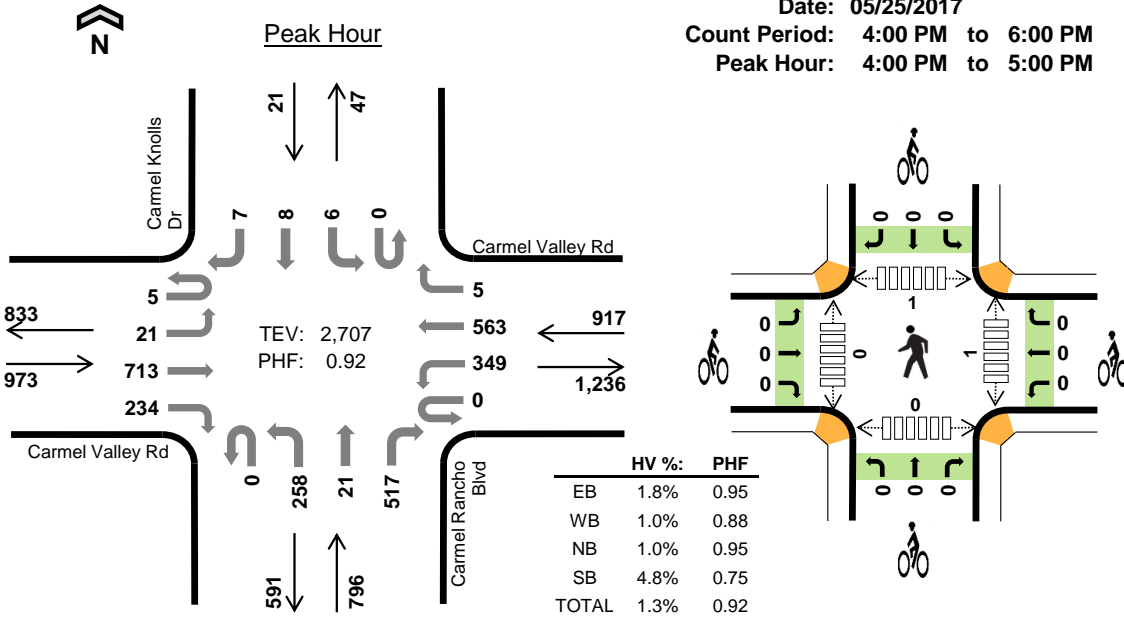

Two-Hour Count Summaries

Interval Start	Carmel Valley Rd Eastbound				Carmel Valley Rd Westbound				Carmel Rancho Blvd Northbound				Carmel Rancho Blvd Southbound				15-min Total	Rolling One Hour	
	UT	LT	TH	RT	UT	LT	TH	RT	UT	LT	TH	RT	UT	LT	TH	RT			
4:00 PM	3	3	183	66	0	100	159	2	0	70	3	137	0	3	2	2	733	0	
4:15 PM	1	5	157	55	0	90	123	0	0	68	6	136	0	1	2	3	647	0	
4:30 PM	0	5	194	55	0	62	150	2	0	63	9	107	0	1	1	1	650	0	
4:45 PM	1	8	179	58	0	97	131	1	0	57	3	137	0	1	3	1	677	2,707	
5:00 PM	0	7	138	66	0	62	126	4	0	132	2	135	0	2	8	1	683	2,657	
5:15 PM	1	5	193	69	0	74	134	1	0	57	1	113	0	2	2	2	654	2,664	
5:30 PM	0	2	151	44	0	70	107	1	0	65	3	101	0	1	5	1	551	2,565	
5:45 PM	1	4	143	45	0	65	111	2	0	61	4	60	0	0	3	3	502	2,390	
Count Total	7	39	1,338	458	0	620	1,041	13	0	573	31	926	0	11	26	14	5,097	0	
Peak Hour	All	5	21	713	234	0	349	563	5	0	258	21	517	0	6	8	7	2,707	0
	HV	0	0	18	0	0	4	5	0	0	1	0	7	0	0	1	0	36	0
	HV%	0%	0%	3%	0%	-	1%	1%	0%	-	0%	0%	1%	-	0%	13%	0%	1%	0

Note: Two-hour count summary volumes include heavy vehicles but exclude bicycles in overall count.

Interval Start	Heavy Vehicle Totals					Bicycles					Pedestrians (Crossing Leg)				
	EB	WB	NB	SB	Total	EB	WB	NB	SB	Total	East	West	North	South	Total
4:00 PM	6	3	3	0	12	0	0	0	0	0	0	0	1	0	1
4:15 PM	3	3	1	1	8	0	0	0	0	0	0	0	0	0	0
4:30 PM	6	1	3	0	10	0	0	0	0	0	1	0	0	0	1
4:45 PM	3	2	1	0	6	0	0	0	0	0	0	0	0	0	0
5:00 PM	5	1	2	0	8	0	0	0	0	0	0	0	0	0	0
5:15 PM	2	6	0	0	8	0	0	1	0	1	0	0	0	0	0
5:30 PM	7	3	2	0	12	0	0	0	0	0	1	0	0	0	1
5:45 PM	2	2	1	0	5	1	0	0	0	1	0	0	0	0	0
Count Total	34	21	13	1	69	1	0	1	0	2	2	0	1	0	3
Peak Hour	18	9	8	1	36	0	0	0	0	0	1	0	1	0	2

Crossroads Blvd Rio Rd



Peak Hour

Date: 05/25/2017
Count Period: 7:00 AM to 9:00 AM
Peak Hour: 8:00 AM to 9:00 AM

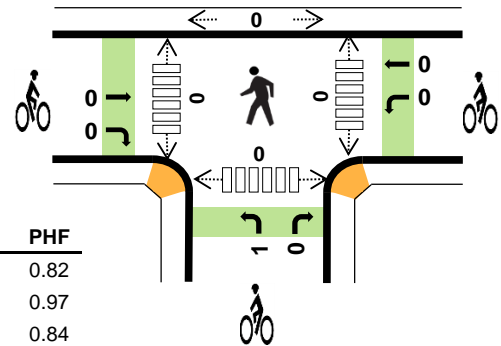
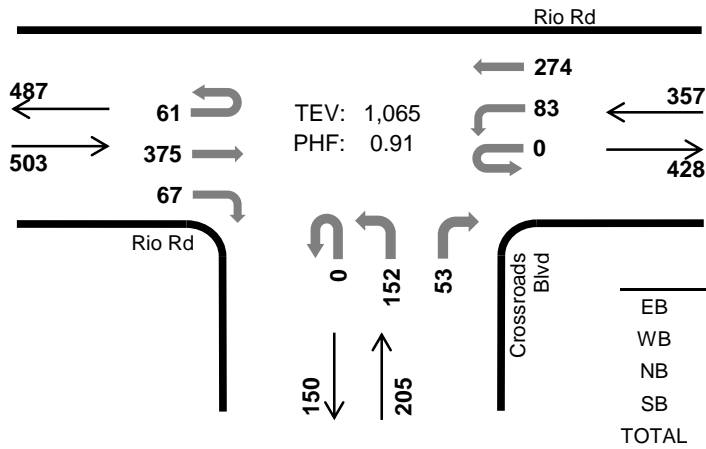

	HV %:	PHF
EB	2.8%	0.82
WB	5.6%	0.97
NB	4.9%	0.84
SB	-	-
TOTAL	4.1%	0.91

Two-Hour Count Summaries

Interval Start	Rio Rd Eastbound				Rio Rd Westbound				Crossroads Blvd Northbound				0 Southbound				15-min Total	Rolling One Hour
	UT	LT	TH	RT	UT	LT	TH	RT	UT	LT	TH	RT	UT	LT	TH	RT		
7:00 AM	10	0	44	10	0	10	32	0	0	17	0	6	0	0	0	0	129	0
7:15 AM	5	0	55	6	0	17	48	0	0	26	0	16	0	0	0	0	173	0
7:30 AM	19	0	71	14	0	22	89	0	0	33	0	14	0	0	0	0	262	0
7:45 AM	15	0	77	22	0	15	57	0	0	27	0	6	0	0	0	0	219	783
8:00 AM	18	0	77	16	0	21	71	0	0	29	0	10	0	0	0	0	242	896
8:15 AM	15	0	87	10	0	20	72	0	0	48	0	13	0	0	0	0	265	988
8:30 AM	12	0	94	21	0	18	66	0	0	39	0	16	0	0	0	0	266	992
8:45 AM	16	0	117	20	0	24	65	0	0	36	0	14	0	0	0	0	292	1,065
Count Total	110	0	622	119	0	147	500	0	0	255	0	95	0	0	0	0	1,848	0
Peak Hour	All	61	0	375	67	0	83	274	0	0	152	0	53	0	0	0	1,065	0
	HV	1	0	11	2	0	6	14	0	0	6	0	4	0	0	0	44	0
	HV%	2%	-	3%	3%	-	7%	5%	-	-	4%	-	8%	-	-	-	4%	0

Note: Two-hour count summary volumes include heavy vehicles but exclude bicycles in overall count.

Interval Start	Heavy Vehicle Totals					Bicycles					Pedestrians (Crossing Leg)				
	EB	WB	NB	SB	Total	EB	WB	NB	SB	Total	East	West	North	South	Total
7:00 AM	7	5	5	0	17	0	0	0	0	0	0	0	0	0	0
7:15 AM	0	2	3	0	5	1	0	0	0	1	1	0	0	0	1
7:30 AM	0	5	3	0	8	0	0	0	0	0	0	0	0	0	0
7:45 AM	4	2	4	0	10	0	0	0	0	0	0	0	0	0	0
8:00 AM	4	5	3	0	12	0	0	0	0	0	0	0	0	0	0
8:15 AM	4	5	2	0	11	0	0	0	0	0	0	0	0	0	0
8:30 AM	3	6	2	0	11	0	0	0	0	0	0	0	0	0	0
8:45 AM	3	4	3	0	10	0	0	1	0	1	0	0	0	0	0
Count Total	25	34	25	0	84	1	0	1	0	2	1	0	0	0	1
Peak Hr	14	20	10	0	44	0	0	1	0	1	0	0	0	0	0

Crossroads Blvd Rio Rd



Peak Hour

Date: 05/25/2017
 Count Period: 4:00 PM to 6:00 PM
 Peak Hour: 4:00 PM to 5:00 PM

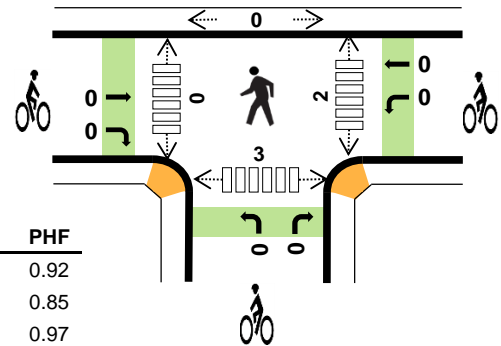
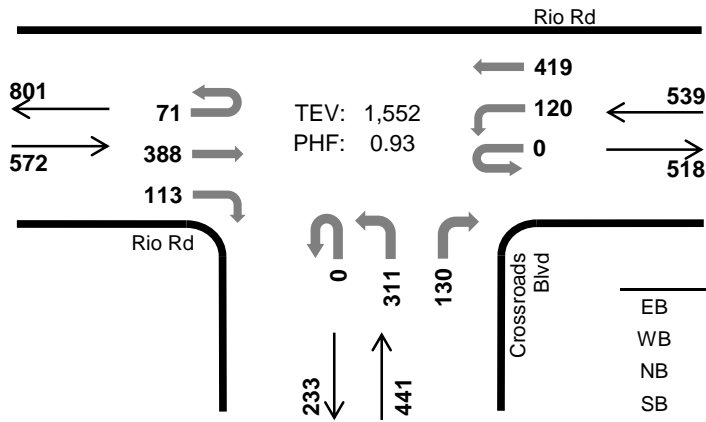

	HV %:	PHF
EB	1.2%	0.92
WB	1.3%	0.85
NB	1.1%	0.97
SB	-	-
TOTAL	1.2%	0.93

Two-Hour Count Summaries

Interval Start	Rio Rd Eastbound				Rio Rd Westbound				Crossroads Blvd Northbound				0 Southbound				15-min Total	Rolling One Hour	
	UT	LT	TH	RT	UT	LT	TH	RT	UT	LT	TH	RT	UT	LT	TH	RT			
4:00 PM	18	0	95	33	0	32	126	0	0	82	0	31	0	0	0	0	417	0	
4:15 PM	15	0	103	21	0	30	99	0	0	77	0	37	0	0	0	0	382	0	
4:30 PM	16	0	87	29	0	33	89	0	0	75	0	31	0	0	0	0	360	0	
4:45 PM	22	0	103	30	0	25	105	0	0	77	0	31	0	0	0	0	393	1,552	
5:00 PM	16	0	82	21	0	24	105	0	0	54	0	25	0	0	0	0	327	1,462	
5:15 PM	22	0	66	28	0	24	88	0	0	55	0	30	0	0	0	0	313	1,393	
5:30 PM	11	0	54	23	0	14	84	0	0	80	0	27	0	0	0	0	293	1,326	
5:45 PM	17	0	48	19	0	24	84	0	0	71	0	20	0	0	0	0	283	1,216	
Count Total	137	0	638	204	0	206	780	0	0	571	0	232	0	0	0	0	2,768	0	
Peak Hour	All	71	0	388	113	0	120	419	0	0	311	0	130	0	0	0	0	1,552	0
	HV	0	0	7	0	0	2	5	0	0	2	0	3	0	0	0	0	19	0
	HV%	0%	-	2%	0%	-	2%	1%	-	-	1%	-	2%	-	-	-	-	1%	0

Note: Two-hour count summary volumes include heavy vehicles but exclude bicycles in overall count.

Interval Start	Heavy Vehicle Totals					Bicycles					Pedestrians (Crossing Leg)				
	EB	WB	NB	SB	Total	EB	WB	NB	SB	Total	East	West	North	South	Total
4:00 PM	1	3	1	0	5	0	0	0	0	0	2	0	0	0	2
4:15 PM	3	2	3	0	8	0	0	0	0	0	0	0	0	0	0
4:30 PM	1	1	0	0	2	0	0	0	0	0	0	0	0	1	1
4:45 PM	2	1	1	0	4	0	0	0	0	0	0	0	0	2	2
5:00 PM	1	0	2	0	3	0	0	0	0	0	0	0	0	1	1
5:15 PM	0	1	1	0	2	0	0	1	0	1	0	0	0	0	0
5:30 PM	1	2	1	0	4	0	0	0	0	0	0	0	0	0	0
5:45 PM	0	1	0	0	1	0	0	0	0	0	0	0	0	0	0
Count Total	9	11	9	0	29	0	0	1	0	1	2	0	0	4	6
Peak Hr	7	7	5	0	19	0	0	0	0	0	2	0	0	3	5

Carmel Center PI Rio Rd



Date: 05/25/2017
Count Period: 7:00 AM to 9:00 AM
Peak Hour: 8:00 AM to 9:00 AM

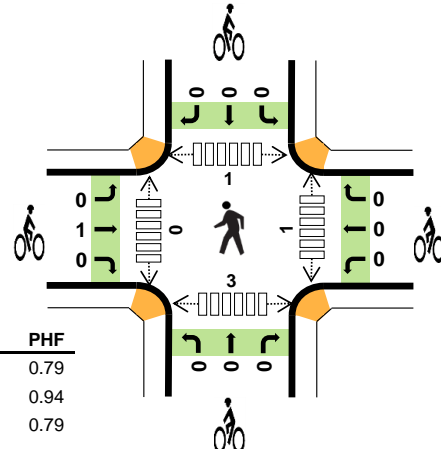
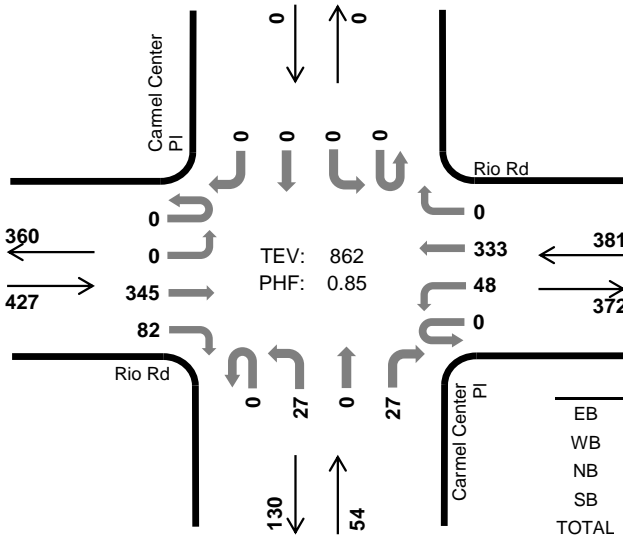

Two-Hour Count Summaries

Interval Start	Rio Rd Eastbound				Rio Rd Westbound				Carmel Center PI Northbound				Carmel Center PI Southbound				15-min Total	Rolling One Hour	
	UT	LT	TH	RT	UT	LT	TH	RT	UT	LT	TH	RT	UT	LT	TH	RT			
7:00 AM	0	0	38	12	0	5	46	0	0	4	0	7	0	0	0	0	112	0	
7:15 AM	0	0	57	8	0	13	65	0	0	6	0	4	0	0	0	0	153	0	
7:30 AM	0	0	64	10	0	8	99	1	0	5	0	2	0	0	1	0	190	0	
7:45 AM	0	0	69	23	0	11	66	0	0	6	0	10	0	0	0	0	185	640	
8:00 AM	0	0	63	18	0	8	84	0	0	7	0	7	0	0	0	0	187	715	
8:15 AM	0	0	79	21	0	13	87	0	0	8	0	3	0	0	0	0	211	773	
8:30 AM	0	0	92	19	0	7	81	0	0	5	0	7	0	0	0	0	211	794	
8:45 AM	0	0	111	24	0	20	81	0	0	7	0	10	0	0	0	0	253	862	
Count Total	0	0	573	135	0	85	609	1	0	48	0	50	0	0	1	0	1,502	0	
Peak Hour	All	0	0	345	82	0	48	333	0	0	27	0	27	0	0	0	0	862	0
	HV	0	0	9	2	0	0	13	0	0	4	0	4	0	0	0	0	32	0
	HV%	-	-	3%	2%	-	0%	4%	-	-	15%	-	15%	-	-	-	-	4%	0

Note: Two-hour count summary volumes include heavy vehicles but exclude bicycles in overall count.

Interval Start	Heavy Vehicle Totals					Bicycles					Pedestrians (Crossing Leg)				
	EB	WB	NB	SB	Total	EB	WB	NB	SB	Total	East	West	North	South	Total
7:00 AM	3	5	0	0	8	0	0	0	0	0	0	0	0	0	0
7:15 AM	2	0	3	0	5	0	0	0	0	0	1	0	2	1	4
7:30 AM	1	4	0	0	5	0	0	0	0	0	0	0	0	0	0
7:45 AM	2	3	2	0	7	0	0	0	0	0	0	0	0	0	0
8:00 AM	3	4	0	0	7	0	0	0	0	0	1	0	0	2	3
8:15 AM	4	4	3	0	11	0	0	0	0	0	0	0	0	1	1
8:30 AM	1	3	3	0	7	1	0	0	0	1	0	0	1	0	1
8:45 AM	3	2	2	0	7	0	0	0	0	0	0	0	0	0	0
Count Total	19	25	13	0	57	1	0	0	0	1	2	0	3	4	9
Peak Hour	11	13	8	0	32	1	0	0	0	1	1	0	1	3	5

Carmel Center PI Rio Rd



Date: 05/25/2017
Count Period: 4:00 PM to 6:00 PM
Peak Hour: 4:00 PM to 5:00 PM

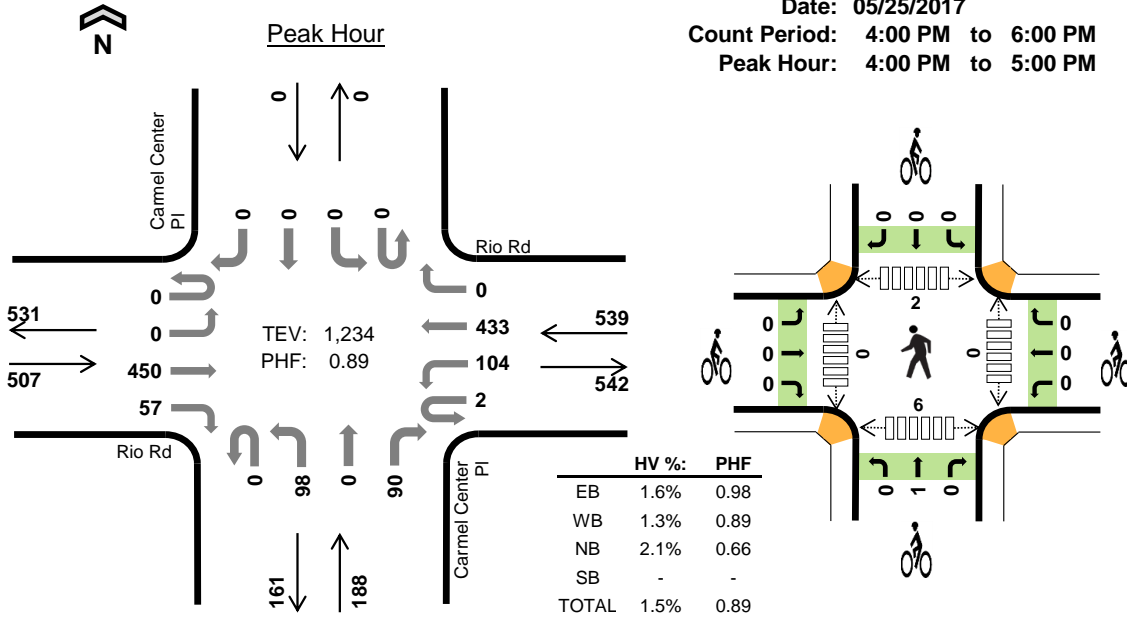

Two-Hour Count Summaries

Interval Start	Rio Rd Eastbound				Rio Rd Westbound				Carmel Center PI Northbound				Carmel Center PI Southbound				15-min Total	Rolling One Hour	
	UT	LT	TH	RT	UT	LT	TH	RT	UT	LT	TH	RT	UT	LT	TH	RT			
4:00 PM	0	0	107	18	0	29	122	0	0	35	0	36	0	0	0	0	347	0	
4:15 PM	0	0	122	6	1	23	113	0	0	18	0	21	0	0	0	0	304	0	
4:30 PM	0	0	106	18	0	30	88	0	0	21	0	13	0	0	0	0	276	0	
4:45 PM	0	0	115	15	1	22	110	0	0	24	0	20	0	0	0	0	307	1,234	
5:00 PM	0	0	92	12	1	16	103	0	0	23	0	26	0	0	0	0	273	1,160	
5:15 PM	0	0	84	8	0	19	91	1	0	21	0	13	0	0	0	0	237	1,093	
5:30 PM	0	0	73	9	0	14	82	0	0	26	0	13	0	0	0	1	218	1,035	
5:45 PM	0	0	62	4	0	14	76	0	0	27	0	9	0	0	0	0	192	920	
Count Total	0	0	761	90	3	167	785	1	0	195	0	151	0	0	0	1	2,154	0	
Peak Hour	All	0	0	450	57	2	104	433	0	0	98	0	90	0	0	0	0	1,234	0
	HV	0	0	7	1	0	3	4	0	0	2	0	2	0	0	0	0	19	0
	HV%	-	-	2%	2%	0%	3%	1%	-	-	2%	-	2%	-	-	-	-	2%	0

Note: Two-hour count summary volumes include heavy vehicles but exclude bicycles in overall count.

Interval Start	Heavy Vehicle Totals					Bicycles					Pedestrians (Crossing Leg)				
	EB	WB	NB	SB	Total	EB	WB	NB	SB	Total	East	West	North	South	Total
4:00 PM	1	2	0	0	3	0	0	0	0	0	0	0	2	1	3
4:15 PM	3	3	0	0	6	0	0	0	0	0	0	0	0	3	3
4:30 PM	1	2	3	0	6	0	0	1	0	1	0	0	0	2	2
4:45 PM	3	0	1	0	4	0	0	0	0	0	0	0	0	0	0
5:00 PM	0	0	0	0	0	0	0	0	0	0	0	0	0	1	1
5:15 PM	1	2	0	0	3	2	0	0	0	2	0	0	4	3	7
5:30 PM	0	1	0	0	1	0	0	0	0	0	0	0	0	0	0
5:45 PM	1	0	1	0	2	0	0	0	0	0	0	0	0	0	0
Count Total	10	10	5	0	25	2	0	1	0	3	0	0	6	10	16
Peak Hour	8	7	4	0	19	0	0	1	0	1	0	0	2	6	8

Carmel Rancho Blvd Rio Rd



Date: 05/25/2017
Count Period: 7:00 AM to 9:00 AM
Peak Hour: 8:00 AM to 9:00 AM

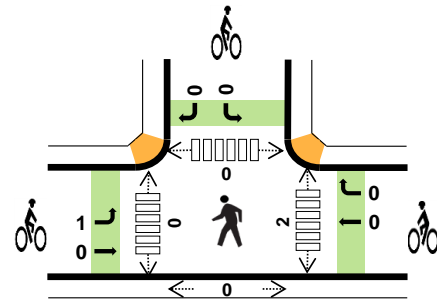
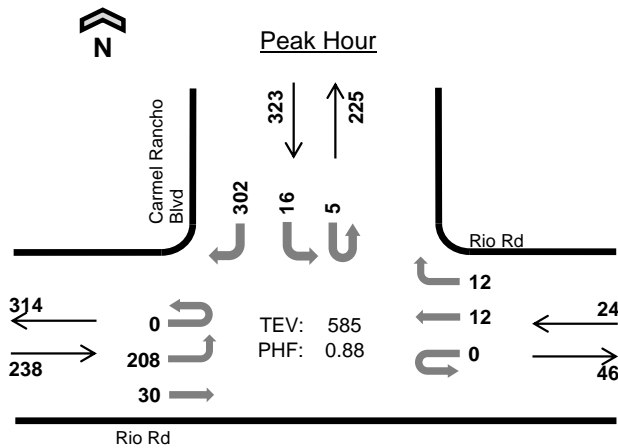

	HV %:	PHF
EB	4.2%	0.76
WB	0.0%	0.46
NB	-	-
SB	2.8%	0.96
TOTAL	3.2%	0.88

Two-Hour Count Summaries

Interval Start	Rio Rd Eastbound				Rio Rd Westbound				0 Northbound				Carmel Rancho Blvd Southbound				15-min Total	Rolling One Hour	
	UT	LT	TH	RT	UT	LT	TH	RT	UT	LT	TH	RT	UT	LT	TH	RT			
7:00 AM	0	27	3	0	0	0	6	3	0	0	0	0	3	1	0	33	76	0	
7:15 AM	0	50	1	0	0	0	6	7	0	0	0	0	0	1	0	52	117	0	
7:30 AM	1	47	3	0	0	0	6	9	0	0	0	0	0	3	0	89	158	0	
7:45 AM	0	39	8	0	0	0	1	1	0	0	0	0	0	7	0	61	117	468	
8:00 AM	0	38	4	0	0	0	4	1	0	0	0	0	1	6	0	77	131	523	
8:15 AM	0	51	7	0	0	0	5	8	0	0	0	0	1	4	0	72	148	554	
8:30 AM	0	51	9	0	0	0	2	0	0	0	0	0	2	1	0	75	140	536	
8:45 AM	0	68	10	0	0	0	1	3	0	0	0	0	1	5	0	78	166	585	
Count Total	1	371	45	0	0	0	31	32	0	0	0	0	8	28	0	537	1,053	0	
Peak Hour	All	0	208	30	0	0	0	12	12	0	0	0	0	5	16	0	302	585	0
	HV	0	10	0	0	0	0	0	0	0	0	0	0	1	0	0	8	19	0
	HV%	-	5%	0%	-	-	-	0%	0%	-	-	-	-	20%	0%	-	3%	3%	0

Note: Two-hour count summary volumes include heavy vehicles but exclude bicycles in overall count.

Interval Start	Heavy Vehicle Totals					Bicycles					Pedestrians (Crossing Leg)				
	EB	WB	NB	SB	Total	EB	WB	NB	SB	Total	East	West	North	South	Total
7:00 AM	2	1	0	3	6	0	0	0	0	0	0	0	0	0	0
7:15 AM	1	1	0	1	3	0	0	0	0	0	0	0	0	0	0
7:30 AM	1	1	0	4	6	0	0	0	0	0	0	0	0	0	0
7:45 AM	1	0	0	1	2	0	0	0	0	0	0	0	0	0	0
8:00 AM	4	0	0	4	8	0	0	0	0	0	0	0	0	0	0
8:15 AM	2	0	0	1	3	0	0	0	0	0	2	0	0	0	2
8:30 AM	2	0	0	2	4	1	0	0	0	1	0	0	0	0	0
8:45 AM	2	0	0	2	4	0	0	0	0	0	0	0	0	0	0
Count Total	15	3	0	18	36	1	0	0	0	1	2	0	0	0	2
Peak Hr	10	0	0	9	19	1	0	0	0	1	2	0	0	0	2

Carmel Rancho Blvd Rio Rd



Date: 05/25/2017
Count Period: 4:00 PM to 6:00 PM
Peak Hour: 4:00 PM to 5:00 PM

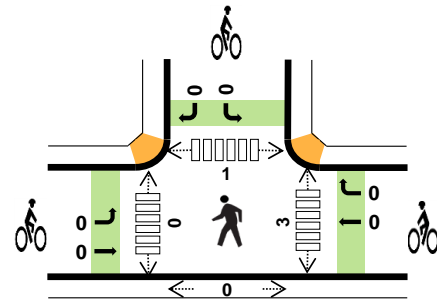
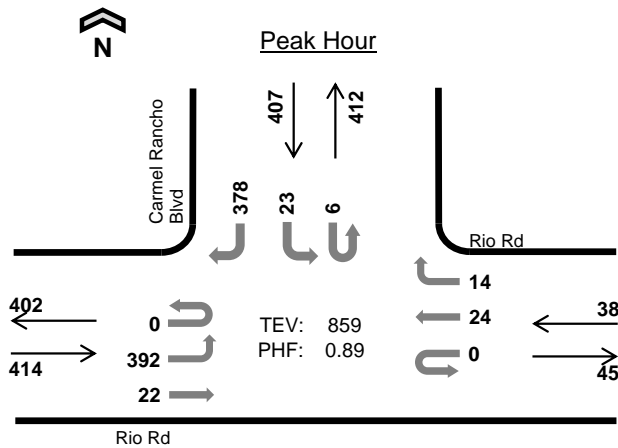

	HV %:	PHF
EB	2.2%	0.94
WB	0.0%	0.63
NB	-	-
SB	1.7%	0.88
TOTAL	1.9%	0.89

Two-Hour Count Summaries

Interval Start	Rio Rd Eastbound				Rio Rd Westbound				0 Northbound				Carmel Rancho Blvd Southbound				15-min Total	Rolling One Hour	
	UT	LT	TH	RT	UT	LT	TH	RT	UT	LT	TH	RT	UT	LT	TH	RT			
4:00 PM	0	103	7	0	0	0	13	2	0	0	0	0	2	5	0	109	241	0	
4:15 PM	0	96	5	0	0	0	4	3	0	0	0	0	2	7	0	91	208	0	
4:30 PM	0	91	3	0	0	0	4	5	0	0	0	0	1	6	0	87	197	0	
4:45 PM	0	102	7	0	0	0	3	4	0	0	0	0	1	5	0	91	213	859	
5:00 PM	1	90	6	0	0	0	4	8	0	0	0	0	0	4	0	78	191	809	
5:15 PM	0	69	8	0	0	0	5	5	0	0	0	0	1	4	0	85	177	778	
5:30 PM	0	60	6	0	0	0	5	4	0	0	0	0	1	3	0	61	140	721	
5:45 PM	1	46	6	0	0	0	4	1	0	0	0	0	0	0	0	66	124	632	
Count Total	2	657	48	0	0	0	42	32	0	0	0	0	8	34	0	668	1,491	0	
Peak Hour	All	0	392	22	0	0	0	24	14	0	0	0	0	6	23	0	378	859	0
	HV	0	9	0	0	0	0	0	0	0	0	0	0	0	0	0	7	16	0
	HV%	-	2%	0%	-	-	-	0%	0%	-	-	-	-	0%	0%	-	2%	2%	0

Note: Two-hour count summary volumes include heavy vehicles but exclude bicycles in overall count.

Interval Start	Heavy Vehicle Totals					Bicycles					Pedestrians (Crossing Leg)				
	EB	WB	NB	SB	Total	EB	WB	NB	SB	Total	East	West	North	South	Total
4:00 PM	1	0	0	2	3	0	0	0	0	0	1	0	0	0	1
4:15 PM	3	0	0	4	7	0	0	0	0	0	1	0	0	0	1
4:30 PM	3	0	0	1	4	0	0	0	0	0	1	0	1	0	2
4:45 PM	2	0	0	0	2	0	0	0	0	0	0	0	0	0	0
5:00 PM	0	0	0	0	0	0	0	0	0	0	4	0	1	0	5
5:15 PM	0	0	0	2	2	0	0	0	0	0	0	0	0	0	0
5:30 PM	2	0	0	1	3	0	0	0	0	0	0	0	0	0	0
5:45 PM	0	0	0	0	0	0	0	0	0	0	0	1	1	0	2
Count Total	11	0	0	10	21	0	0	0	0	0	7	1	3	0	11
Peak Hr	9	0	0	7	16	0	0	0	0	0	3	0	1	0	4

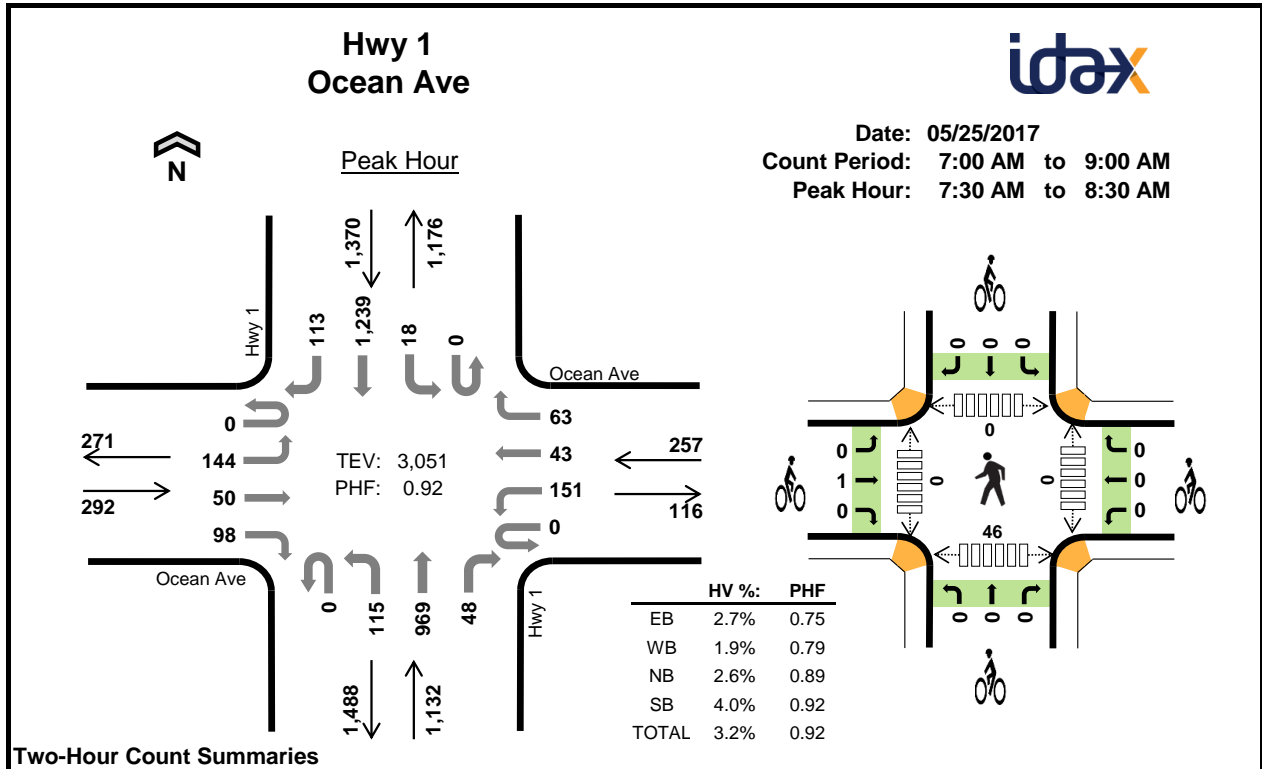

Two-Hour Count Summaries

Interval Start	Ocean Ave Eastbound				Ocean Ave Westbound				Hwy 1 Northbound				Hwy 1 Southbound				15-min Total	Rolling One Hour	
	UT	LT	TH	RT	UT	LT	TH	RT	UT	LT	TH	RT	UT	LT	TH	RT			
7:00 AM	0	20	1	10	0	9	1	5	0	19	143	2	0	4	238	31	483	0	
7:15 AM	0	27	9	19	0	29	5	14	0	20	187	1	0	8	261	34	614	0	
7:30 AM	0	28	7	20	0	47	10	23	0	30	266	21	0	7	340	27	826	0	
7:45 AM	0	44	13	22	0	24	16	14	0	22	243	4	0	5	332	25	764	2,687	
8:00 AM	0	29	6	26	0	29	2	11	0	32	257	9	0	2	310	39	752	2,956	
8:15 AM	0	43	24	30	0	51	15	15	0	31	203	14	0	4	257	22	709	3,051	
8:30 AM	0	44	3	27	0	16	6	6	0	23	249	6	0	1	365	15	761	2,986	
8:45 AM	0	56	4	30	0	8	5	2	0	40	238	1	0	1	306	40	731	2,953	
Count Total	0	291	67	184	0	213	60	90	0	217	1,786	58	0	32	2,409	233	5,640	0	
Peak Hour	All	0	144	50	98	0	151	43	63	0	115	969	48	0	18	1,239	113	3,051	0
	HV	0	5	1	2	0	5	0	0	0	2	27	0	0	0	52	3	97	0
	HV%	-	3%	2%	2%	-	3%	0%	0%	-	2%	3%	0%	-	0%	4%	3%	3%	0

Note: Two-hour count summary volumes include heavy vehicles but exclude bicycles in overall count.

Interval Start	Heavy Vehicle Totals					Bicycles					Pedestrians (Crossing Leg)				
	EB	WB	NB	SB	Total	EB	WB	NB	SB	Total	East	West	North	South	Total
7:00 AM	0	0	5	7	12	0	0	0	0	0	0	0	0	0	0
7:15 AM	0	4	7	11	22	0	0	0	0	0	0	0	0	0	3
7:30 AM	2	2	7	10	21	0	0	0	0	0	0	0	0	9	9
7:45 AM	2	1	3	13	19	1	0	0	0	1	0	0	0	0	9
8:00 AM	1	2	10	11	24	0	0	0	0	0	0	0	0	0	6
8:15 AM	3	0	9	21	33	0	0	0	0	0	0	0	0	0	22
8:30 AM	1	0	5	21	27	0	0	0	0	0	1	0	0	0	21
8:45 AM	2	0	6	14	22	0	0	0	0	0	0	0	0	0	0
Count Total	11	9	52	108	180	1	0	0	0	1	1	0	0	0	71
Peak Hour	8	5	29	55	97	1	0	0	0	1	0	0	0	0	46

Hwy 1 Ocean Ave



Date: 05/25/2017
 Count Period: 4:00 PM to 6:00 PM
 Peak Hour: 4:00 PM to 5:00 PM

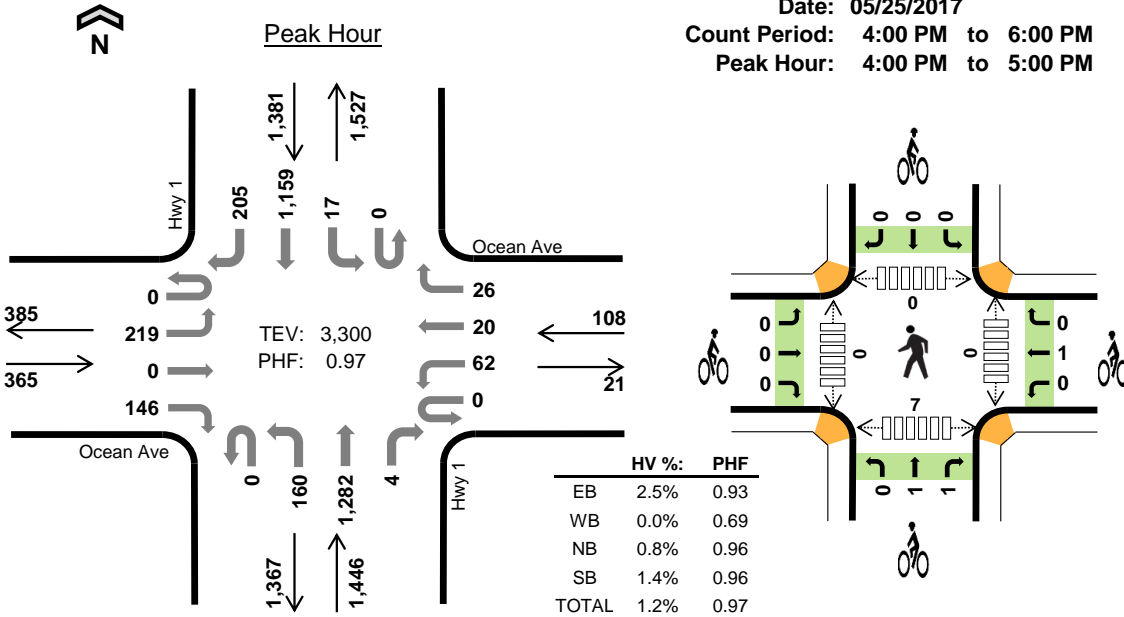

Two-Hour Count Summaries

Interval Start	Ocean Ave Eastbound				Ocean Ave Westbound				Hwy 1 Northbound				Hwy 1 Southbound				15-min Total	Rolling One Hour	
	UT	LT	TH	RT	UT	LT	TH	RT	UT	LT	TH	RT	UT	LT	TH	RT			
4:00 PM	0	58	0	37	0	10	7	6	0	52	319	4	0	2	305	53	853	0	
4:15 PM	0	57	0	41	0	11	7	3	0	41	318	0	0	5	305	36	824	0	
4:30 PM	0	57	0	32	0	27	3	9	0	38	314	0	0	2	251	62	795	0	
4:45 PM	0	47	0	36	0	14	3	8	0	29	331	0	0	8	298	54	828	3,300	
5:00 PM	0	65	9	42	0	23	8	6	0	41	365	0	0	2	253	31	845	3,292	
5:15 PM	0	60	3	35	0	7	2	3	0	36	287	1	0	1	286	38	759	3,227	
5:30 PM	0	68	1	36	0	8	4	0	0	24	282	0	0	3	258	43	727	3,159	
5:45 PM	0	57	3	33	0	14	3	4	0	33	288	3	0	8	245	54	745	3,076	
Count Total	0	469	16	292	0	114	37	39	0	294	2,504	8	0	31	2,201	371	6,376	0	
Peak Hour	All	0	219	0	146	0	62	20	26	0	160	1,282	4	0	17	1,159	205	3,300	0
	HV	0	2	0	7	0	0	0	0	0	0	12	0	0	0	15	4	40	0
	HV%	-	1%	-	5%	-	0%	0%	0%	-	0%	1%	0%	-	0%	1%	2%	1%	0

Note: Two-hour count summary volumes include heavy vehicles but exclude bicycles in overall count.

Interval Start	Heavy Vehicle Totals					Bicycles					Pedestrians (Crossing Leg)				
	EB	WB	NB	SB	Total	EB	WB	NB	SB	Total	East	West	North	South	Total
4:00 PM	5	0	4	3	12	0	0	1	0	1	0	0	0	3	3
4:15 PM	2	0	4	7	13	0	1	0	0	1	0	0	0	4	4
4:30 PM	1	0	2	6	9	0	0	1	0	1	0	0	0	0	0
4:45 PM	1	0	2	3	6	0	0	0	0	0	0	0	0	0	0
5:00 PM	1	0	6	5	12	0	0	0	0	0	0	0	0	2	2
5:15 PM	4	0	5	1	10	0	0	0	0	0	0	0	0	2	2
5:30 PM	1	2	5	6	14	0	0	0	0	0	0	0	0	2	2
5:45 PM	1	0	5	5	11	0	0	0	0	0	0	0	0	0	0
Count Total	16	2	33	36	87	0	1	2	0	3	0	0	0	13	13
Peak Hour	9	0	12	19	40	0	1	2	0	3	0	0	0	7	7

Hwy 1 Carpenter St



Date: 05/25/2017
 Count Period: 7:00 AM to 9:00 AM
 Peak Hour: 7:30 AM to 8:30 AM

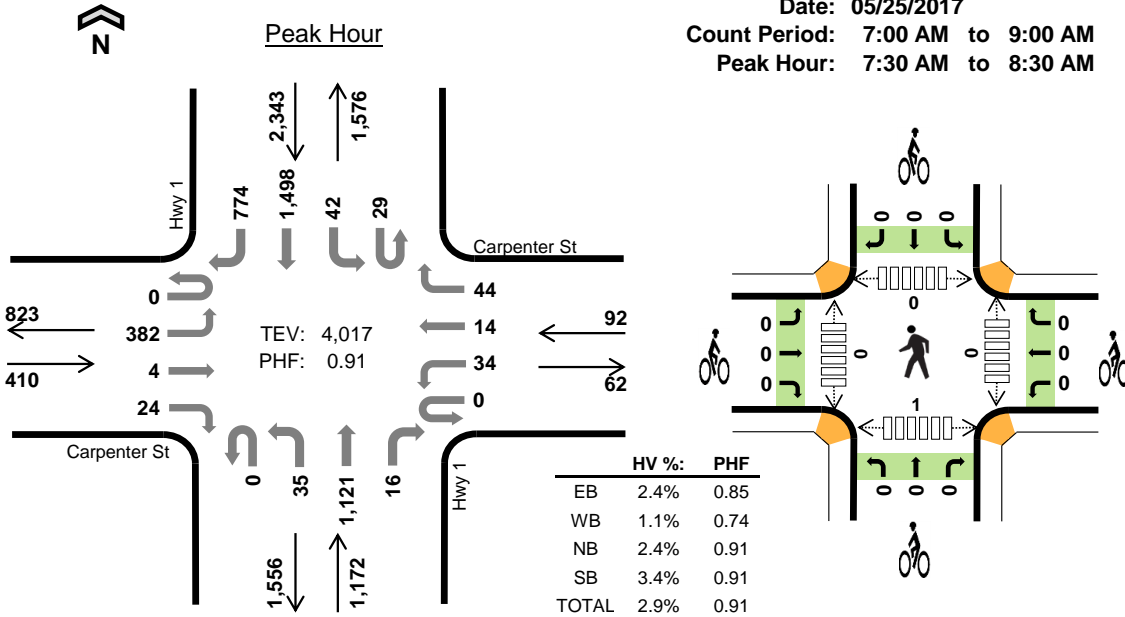

Two-Hour Count Summaries

Interval Start	Carpenter St Eastbound				Carpenter St Westbound				Hwy 1 Northbound				Hwy 1 Southbound				15-min Total	Rolling One Hour	
	UT	LT	TH	RT	UT	LT	TH	RT	UT	LT	TH	RT	UT	LT	TH	RT			
7:00 AM	0	46	2	3	0	4	2	4	0	0	159	3	6	7	282	65	583	0	
7:15 AM	0	54	1	3	0	7	2	8	0	2	244	2	4	7	361	108	803	0	
7:30 AM	0	98	0	3	0	11	2	17	0	6	287	5	5	12	369	197	1,012	0	
7:45 AM	0	112	1	7	0	7	4	8	0	10	307	4	3	10	370	258	1,101	3,499	
8:00 AM	0	111	2	7	0	4	0	8	0	8	276	4	12	13	393	158	996	3,912	
8:15 AM	0	61	1	7	0	12	8	11	0	11	251	3	9	7	366	161	908	4,017	
8:30 AM	0	77	3	2	0	5	6	7	0	6	308	3	4	8	370	168	967	3,972	
8:45 AM	0	86	1	7	0	11	1	15	0	3	308	5	8	9	377	190	1,021	3,892	
Count Total	0	645	11	39	0	61	25	78	0	46	2,140	29	51	73	2,888	1,305	7,391	0	
Peak Hour	All	0	382	4	24	0	34	14	44	0	35	1,121	16	29	42	1,498	774	4,017	0
	HV	0	8	1	1	0	0	1	0	0	1	27	0	0	4	59	16	118	0
	HV%	-	2%	25%	4%	-	0%	7%	0%	-	3%	2%	0%	0%	10%	4%	2%	3%	0

Note: Two-hour count summary volumes include heavy vehicles but exclude bicycles in overall count.

Interval Start	Heavy Vehicle Totals					Bicycles					Pedestrians (Crossing Leg)				
	EB	WB	NB	SB	Total	EB	WB	NB	SB	Total	East	West	North	South	Total
7:00 AM	2	1	4	9	16	0	0	0	0	0	0	0	0	0	0
7:15 AM	1	0	7	15	23	0	1	0	0	1	0	0	0	0	0
7:30 AM	1	0	6	11	18	0	0	0	0	0	0	0	0	0	0
7:45 AM	3	0	4	17	24	0	0	0	0	0	0	0	0	1	1
8:00 AM	4	0	9	23	36	0	0	0	0	0	0	0	0	0	0
8:15 AM	2	1	9	28	40	0	0	0	0	0	0	0	0	0	0
8:30 AM	2	0	5	20	27	0	0	0	0	0	0	0	0	1	1
8:45 AM	3	1	4	15	23	0	0	1	0	1	0	0	0	0	0
Count Total	18	3	48	138	207	0	1	1	0	2	0	0	0	2	2
Peak Hour	10	1	28	79	118	0	0	0	0	0	0	0	0	1	1

Hwy 1 Carpenter St



Date: 05/25/2017
 Count Period: 4:00 PM to 6:00 PM
 Peak Hour: 4:00 PM to 5:00 PM

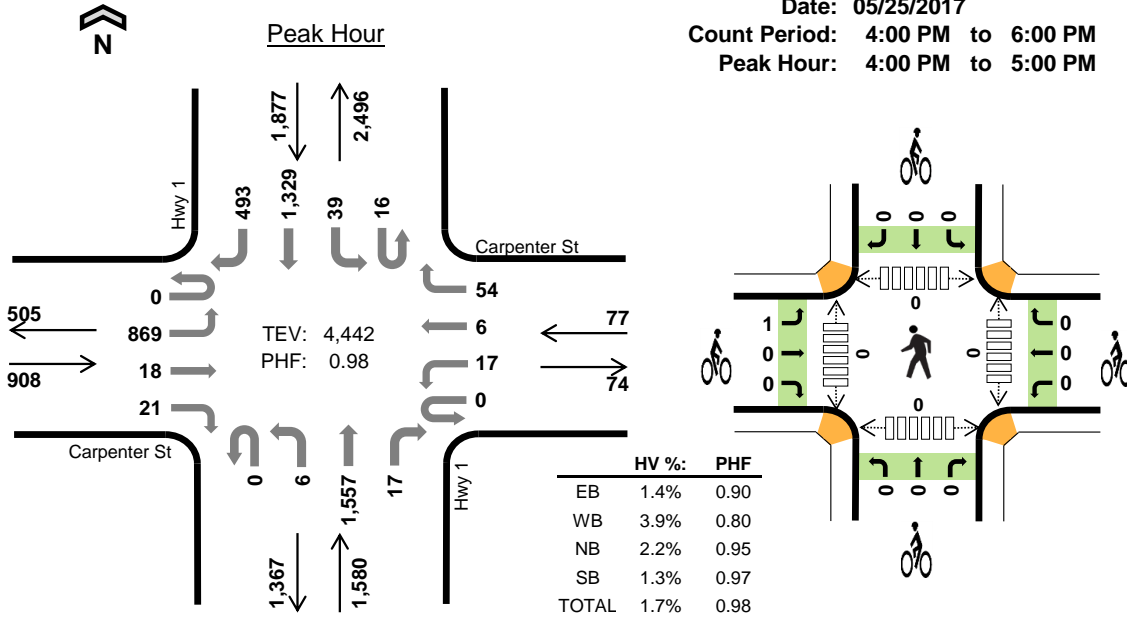

Two-Hour Count Summaries

Interval Start	Carpenter St Eastbound				Carpenter St Westbound				Hwy 1 Northbound				Hwy 1 Southbound				15-min Total	Rolling One Hour	
	UT	LT	TH	RT	UT	LT	TH	RT	UT	LT	TH	RT	UT	LT	TH	RT			
4:00 PM	0	230	4	11	0	5	3	12	0	0	377	5	4	7	315	132	1,105	0	
4:15 PM	0	207	3	0	0	4	1	15	0	0	413	2	3	15	342	123	1,128	0	
4:30 PM	0	240	6	6	0	2	1	10	0	3	359	8	8	7	322	132	1,104	0	
4:45 PM	0	192	5	4	0	6	1	17	0	3	408	2	1	10	350	106	1,105	4,442	
5:00 PM	0	170	4	4	0	2	2	11	0	7	428	6	3	11	312	106	1,066	4,403	
5:15 PM	0	145	5	2	0	6	2	7	0	1	402	6	3	11	322	127	1,039	4,314	
5:30 PM	0	136	3	5	0	2	3	17	0	3	331	3	1	17	297	107	925	4,135	
5:45 PM	0	94	2	5	0	4	3	8	0	4	354	5	2	12	305	116	914	3,944	
Count Total	0	1,414	32	37	0	31	16	97	0	21	3,072	37	25	90	2,565	949	8,386	0	
Peak Hour	All	0	869	18	21	0	17	6	54	0	6	1,557	17	16	39	1,329	493	4,442	0
	HV	0	13	0	0	0	0	0	3	0	0	33	2	0	0	19	6	76	0
	HV%	-	1%	0%	0%	-	0%	0%	6%	-	0%	2%	12%	0%	0%	1%	1%	2%	0

Note: Two-hour count summary volumes include heavy vehicles but exclude bicycles in overall count.

Interval Start	Heavy Vehicle Totals					Bicycles					Pedestrians (Crossing Leg)				
	EB	WB	NB	SB	Total	EB	WB	NB	SB	Total	East	West	North	South	Total
4:00 PM	3	0	13	5	21	1	0	0	0	1	0	0	0	0	0
4:15 PM	5	2	12	9	28	0	0	0	0	0	0	0	0	0	0
4:30 PM	2	1	6	6	15	0	0	0	0	0	0	0	0	0	0
4:45 PM	3	0	4	5	12	0	0	0	0	0	0	0	0	0	0
5:00 PM	4	0	6	7	17	1	0	0	0	1	0	0	0	0	0
5:15 PM	0	0	9	4	13	0	0	0	0	0	0	0	0	0	0
5:30 PM	3	1	8	6	18	0	0	0	0	0	0	0	0	0	0
5:45 PM	3	0	6	9	18	1	0	0	0	1	0	0	0	0	0
Count Total	23	4	64	51	142	3	0	0	0	3	0	0	0	0	0
Peak Hour	13	3	35	25	76	1	0	0	0	1	0	0	0	0	0

Carmel Rancho Blvd Clocktower Dr



Date: 05/25/2017
Count Period: 7:00 AM to 9:00 AM
Peak Hour: 8:00 AM to 9:00 AM

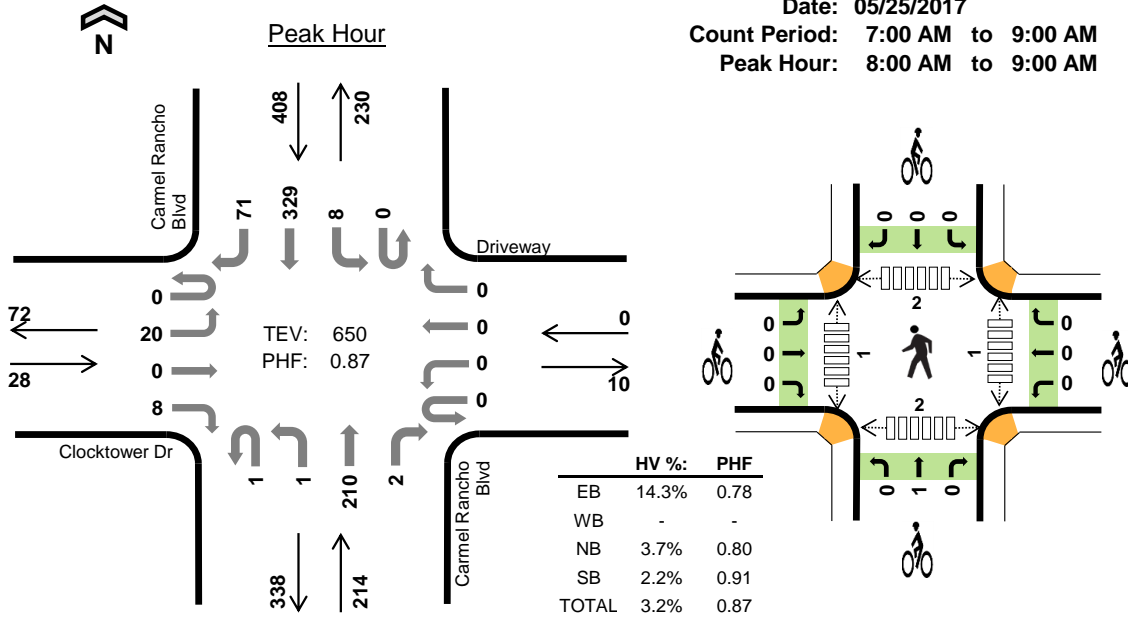

Two-Hour Count Summaries

Interval Start	Clocktower Dr				Driveway				Carmel Rancho Blvd				Carmel Rancho Blvd				15-min Total	Rolling One Hour	
	Eastbound				Westbound				Northbound				Southbound						
	UT	LT	TH	RT	UT	LT	TH	RT	UT	LT	TH	RT	UT	LT	TH	RT			
7:00 AM	0	3	0	1	0	0	0	0	0	1	26	0	0	0	34	7	72	0	
7:15 AM	0	3	0	0	0	0	0	0	0	0	58	0	0	0	59	11	131	0	
7:30 AM	0	6	0	0	0	0	1	0	0	1	53	2	0	0	103	15	181	0	
7:45 AM	0	4	0	1	0	0	0	0	0	1	40	0	0	0	74	26	146	530	
8:00 AM	0	1	0	3	0	0	0	0	0	0	34	0	0	2	82	10	132	590	
8:15 AM	0	7	0	2	0	0	0	0	1	1	57	0	0	2	79	18	167	626	
8:30 AM	0	6	0	1	0	0	0	0	0	0	53	1	0	3	76	24	164	609	
8:45 AM	0	6	0	2	0	0	0	0	0	0	66	1	0	1	92	19	187	650	
Count Total	0	36	0	10	0	0	1	0	1	4	387	4	0	8	599	130	1,180	0	
Peak Hour	All	0	20	0	8	0	0	0	0	1	1	210	2	0	8	329	71	650	0
	HV	0	2	0	2	0	0	0	0	0	0	8	0	0	0	8	1	21	0
	HV%	-	10%	-	25%	-	-	-	-	0%	0%	4%	0%	-	0%	2%	1%	3%	0

Note: Two-hour count summary volumes include heavy vehicles but exclude bicycles in overall count.

Interval Start	Heavy Vehicle Totals					Bicycles					Pedestrians (Crossing Leg)				
	EB	WB	NB	SB	Total	EB	WB	NB	SB	Total	East	West	North	South	Total
7:00 AM	0	0	3	2	5	0	0	0	0	0	0	0	0	0	0
7:15 AM	0	0	2	1	3	0	0	0	0	0	0	0	0	0	0
7:30 AM	1	1	2	3	7	0	0	0	0	0	1	1	0	2	4
7:45 AM	1	0	1	1	3	0	0	0	0	0	0	0	0	0	0
8:00 AM	0	0	2	4	6	0	0	0	0	0	1	0	1	0	2
8:15 AM	2	0	3	1	6	0	0	0	0	0	0	0	0	1	1
8:30 AM	0	0	2	2	4	0	0	1	0	1	0	1	1	1	3
8:45 AM	2	0	1	2	5	0	0	0	0	0	0	0	0	0	0
Count Total	6	1	16	16	39	0	0	1	0	1	2	2	2	4	10
Peak Hour	4	0	8	9	21	0	0	1	0	1	1	1	2	2	6

Carmel Rancho Blvd Clocktower Dr



Date: 05/25/2017
Count Period: 4:00 PM to 6:00 PM
Peak Hour: 4:00 PM to 5:00 PM

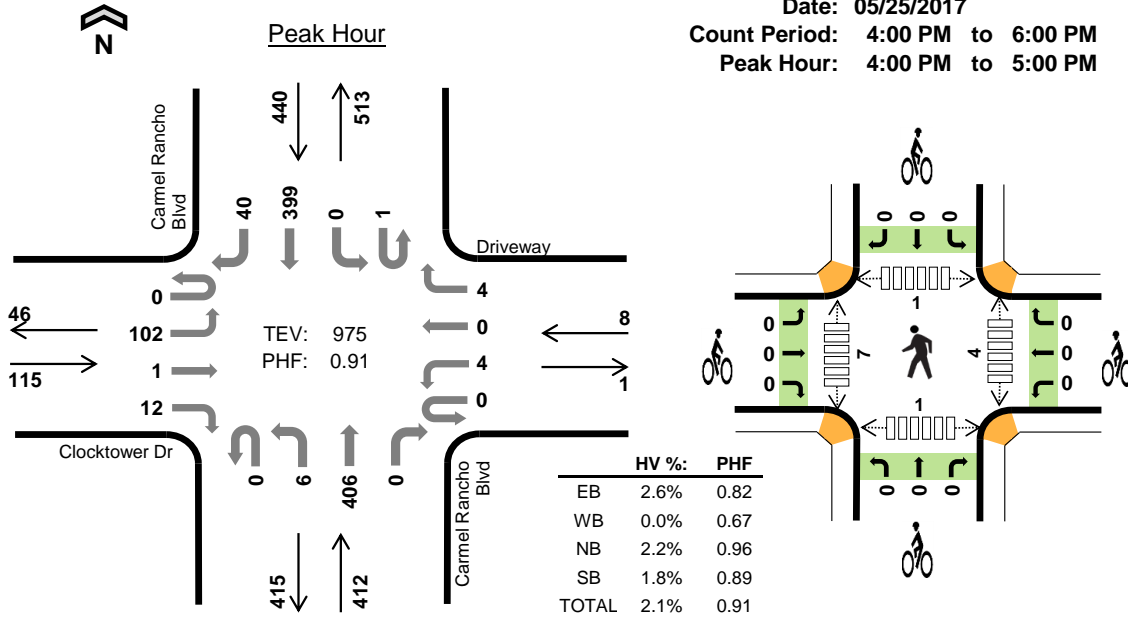

Two-Hour Count Summaries

Interval Start	Clocktower Dr				Driveway				Carmel Rancho Blvd				Carmel Rancho Blvd				15-min Total	Rolling One Hour	
	Eastbound				Westbound				Northbound				Southbound						
	UT	LT	TH	RT	UT	LT	TH	RT	UT	LT	TH	RT	UT	LT	TH	RT			
4:00 PM	0	33	0	2	0	1	0	2	0	0	107	0	0	0	112	11	268	0	
4:15 PM	0	26	0	5	0	1	0	1	0	2	98	0	0	0	103	12	248	0	
4:30 PM	0	20	1	2	0	0	0	0	0	2	98	0	1	0	94	9	227	0	
4:45 PM	0	23	0	3	0	2	0	1	0	2	103	0	0	0	90	8	232	975	
5:00 PM	0	41	0	3	0	2	0	2	0	2	103	1	0	0	76	10	240	947	
5:15 PM	0	21	1	0	0	0	0	0	0	0	70	0	0	0	85	5	182	881	
5:30 PM	0	21	0	2	0	0	1	0	0	0	66	0	0	0	59	3	152	806	
5:45 PM	0	26	0	3	0	0	0	0	0	2	49	0	0	0	61	8	149	723	
Count Total	0	211	2	20	0	6	1	6	0	10	694	1	1	0	680	66	1,698	0	
Peak Hour	All	0	102	1	12	0	4	0	4	0	6	406	0	1	0	399	40	975	0
	HV	0	2	0	1	0	0	0	0	0	0	9	0	0	0	7	1	20	0
	HV%	-	2%	0%	8%	-	0%	-	0%	-	0%	2%	-	0%	-	2%	3%	2%	0

Note: Two-hour count summary volumes include heavy vehicles but exclude bicycles in overall count.

Interval Start	Heavy Vehicle Totals					Bicycles					Pedestrians (Crossing Leg)				
	EB	WB	NB	SB	Total	EB	WB	NB	SB	Total	East	West	North	South	Total
4:00 PM	2	0	1	3	6	0	0	0	0	0	1	0	1	0	2
4:15 PM	0	0	3	4	7	0	0	0	0	0	1	1	0	0	2
4:30 PM	1	0	3	1	5	0	0	0	0	0	1	5	0	0	6
4:45 PM	0	0	2	0	2	0	0	0	0	0	1	1	0	1	3
5:00 PM	0	0	0	1	1	0	0	0	0	0	2	1	0	0	3
5:15 PM	0	0	0	2	2	0	0	0	0	0	0	0	0	0	0
5:30 PM	0	0	0	2	2	0	0	0	0	0	0	0	0	0	0
5:45 PM	0	0	1	0	1	0	0	0	0	0	2	0	0	0	2
Count Total	3	0	10	13	26	0	0	0	0	0	8	8	1	1	18
Peak Hour	3	0	9	8	20	0	0	0	0	0	4	7	1	1	13

Arroyo Carmel Rio Rd



Date: 05/25/2017
 Count Period: 4:00 PM to 6:00 PM
 Peak Hour: 4:00 PM to 5:00 PM

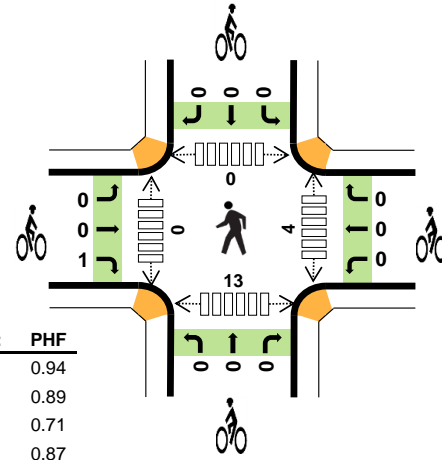
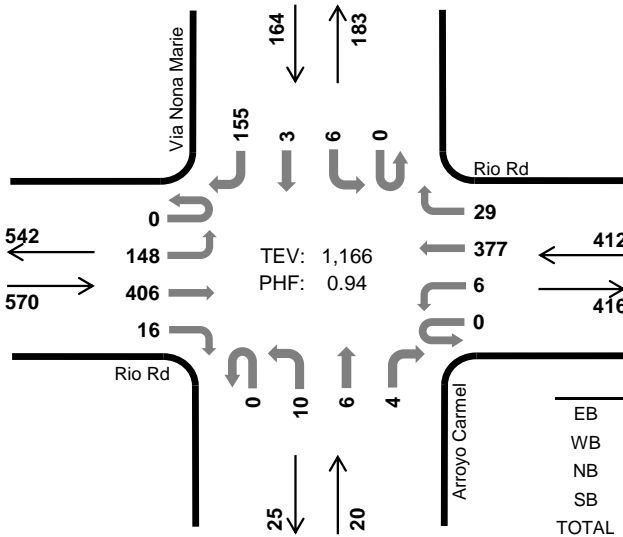

	HV %:	PHF
EB	1.8%	0.94
WB	2.2%	0.89
NB	0.0%	0.71
SB	1.8%	0.87
TOTAL	1.9%	0.94

Two-Hour Count Summaries

Interval Start	Rio Rd Eastbound				Rio Rd Westbound				Arroyo Carmel Northbound				Via Nona Marie Southbound				15-min Total	Rolling One Hour	
	UT	LT	TH	RT	UT	LT	TH	RT	UT	LT	TH	RT	UT	LT	TH	RT			
4:00 PM	0	37	108	6	0	1	109	6	0	4	0	0	0	3	0	36	310	0	
4:15 PM	0	38	99	3	0	1	97	7	0	2	1	0	0	1	1	39	289	0	
4:30 PM	0	35	99	4	0	1	89	8	0	3	2	2	0	0	0	37	280	0	
4:45 PM	0	38	100	3	0	3	82	8	0	1	3	2	0	2	2	43	287	1,166	
5:00 PM	1	31	101	3	0	1	83	5	0	3	0	1	0	1	1	38	269	1,125	
5:15 PM	0	31	75	2	0	0	82	5	0	1	0	3	0	0	0	27	226	1,062	
5:30 PM	0	15	62	4	0	0	55	2	0	2	0	1	0	2	1	25	169	951	
5:45 PM	0	17	55	6	0	2	70	3	0	1	1	0	0	1	0	20	176	840	
Count Total	1	242	699	31	0	9	667	44	0	17	7	9	0	10	5	265	2,006	0	
Peak Hour	All	0	148	406	16	0	6	377	29	0	10	6	4	0	6	3	155	1,166	0
	HV	0	2	8	0	0	0	8	1	0	0	0	0	0	0	0	3	22	0
	HV%	-	1%	2%	0%	-	0%	2%	3%	-	0%	0%	0%	-	0%	0%	2%	2%	0

Note: Two-hour count summary volumes include heavy vehicles but exclude bicycles in overall count.

Interval Start	Heavy Vehicle Totals					Bicycles					Pedestrians (Crossing Leg)				
	EB	WB	NB	SB	Total	EB	WB	NB	SB	Total	East	West	North	South	Total
4:00 PM	1	4	0	1	6	0	0	0	0	0	2	0	0	3	5
4:15 PM	2	4	0	1	7	0	0	0	0	0	0	0	0	5	5
4:30 PM	4	1	0	0	5	0	0	0	0	0	1	0	0	1	2
4:45 PM	3	0	0	1	4	1	0	0	0	1	1	0	0	4	5
5:00 PM	1	0	0	0	1	0	0	0	0	0	2	0	1	4	7
5:15 PM	1	2	0	0	3	0	0	0	0	0	0	0	0	2	2
5:30 PM	2	0	0	1	3	0	0	0	0	0	1	0	0	0	1
5:45 PM	0	1	0	0	1	0	0	0	0	0	0	0	0	2	2
Count Total	14	12	0	4	30	1	0	0	0	1	7	0	1	21	29
Peak Hour	10	9	0	3	22	1	0	0	0	1	4	0	0	13	17

HWY 1 CARMEL VALLEY RD



Peak Hour

Date: 09/30/2017
Count Period: 11:00 AM to 1:00 PM
Peak Hour: 11:45 AM to 12:45 PM

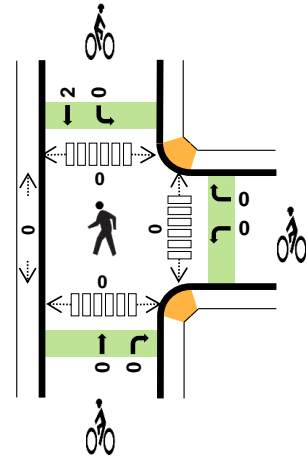
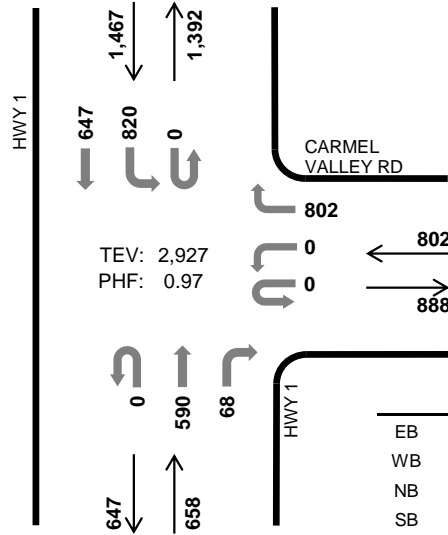

	HV %:	PHF
EB	-	-
WB	0.5%	0.98
NB	0.8%	0.92
SB	1.1%	0.94
TOTAL	0.9%	0.97

Two-Hour Count Summaries

Interval Start	0			CARMEL VALLEY RD			HWY 1			HWY 1			15-min Total	Rolling One Hour				
	Eastbound			Westbound			Northbound			Southbound								
	UT	LT	TH	RT	UT	LT	TH	RT	UT	LT	TH	RT	UT	LT	TH	RT		
11:00 AM	0	0	0	0	0	0	0	184	0	0	139	18	1	185	190	0	717	0
11:15 AM	0	0	0	0	0	0	0	197	0	0	150	16	0	193	191	0	747	0
11:30 AM	0	0	0	0	0	0	0	171	0	0	132	21	0	162	172	0	658	0
11:45 AM	0	0	0	0	0	0	0	204	0	0	139	11	0	205	158	0	717	2,839
12:00 PM	0	0	0	0	0	0	0	202	0	0	144	14	0	210	182	0	752	2,874
12:15 PM	0	0	0	0	0	0	0	201	0	0	158	21	0	204	143	0	727	2,854
12:30 PM	0	0	0	0	0	0	0	195	0	0	149	22	0	201	164	0	731	2,927
12:45 PM	0	0	0	0	0	0	0	182	0	0	177	16	0	148	165	0	688	2,898
Count Total	0	0	0	0	0	0	0	1,536	0	0	1,188	139	1	1,508	1,365	0	5,737	0
Peak Hour	All	0	0	0	0	0	0	802	0	0	590	68	0	820	647	0	2,927	0
	HV	0	0	0	0	0	0	4	0	0	5	0	0	11	5	0	25	0
	HV%	-	-	-	-	-	-	0%	-	-	1%	0%	-	1%	1%	-	1%	0

Note: Two-hour count summary volumes include heavy vehicles but exclude bicycles in overall count.

Interval Start	Heavy Vehicle Totals					Bicycles					Pedestrians (Crossing Leg)				
	EB	WB	NB	SB	Total	EB	WB	NB	SB	Total	East	West	North	South	Total
11:00 AM	0	2	4	0	6	0	0	0	0	0	0	0	0	0	0
11:15 AM	0	0	4	4	8	0	0	0	0	0	0	0	0	0	0
11:30 AM	0	2	1	2	5	0	0	0	0	0	0	0	0	0	0
11:45 AM	0	1	0	3	4	0	0	0	0	0	0	0	0	0	0
12:00 PM	0	2	2	4	8	0	0	0	2	2	0	0	0	0	0
12:15 PM	0	0	3	3	6	0	0	0	0	0	0	0	0	0	0
12:30 PM	0	1	0	6	7	0	0	0	0	0	0	0	0	0	0
12:45 PM	0	3	3	1	7	0	0	0	0	0	0	0	0	0	0
Count Total	0	11	17	23	51	0	0	0	2	2	0	0	0	0	0
Peak Hr	0	4	5	16	25	0	0	0	2	2	0	0	0	0	0

CARMEL RANCHO BLVD CARMEL VALLEY RD



Date: 09/30/2017
Count Period: 11:00 AM to 1:00 PM
Peak Hour: 11:45 AM to 12:45 PM

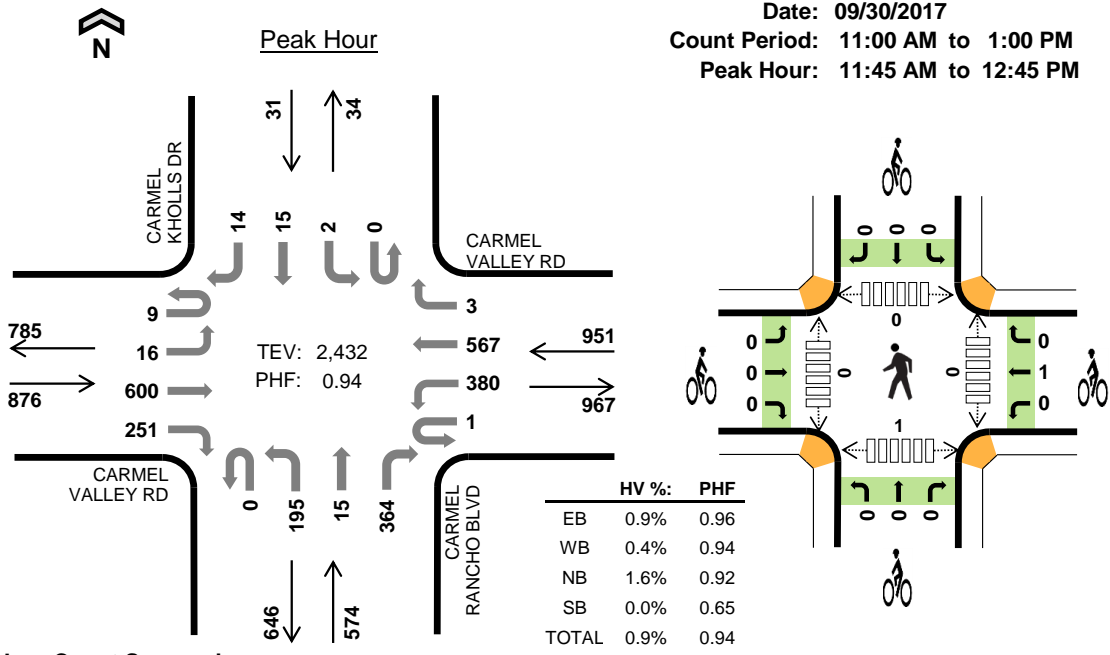

Two-Hour Count Summaries

Interval Start	CARMEL VALLEY RD Eastbound				CARMEL VALLEY RD Westbound				CARMEL RANCHO BLVD Northbound				CARMEL KHOLLS DR Southbound				15-min Total	Rolling One Hour	
	UT	LT	TH	RT	UT	LT	TH	RT	UT	LT	TH	RT	UT	LT	TH	RT			
11:00 AM	0	5	132	62	0	109	120	1	0	60	5	77	0	2	6	5	584	0	
11:15 AM	0	2	137	64	0	119	144	1	0	49	3	88	0	0	2	2	611	0	
11:30 AM	3	2	139	61	0	83	132	3	0	44	4	95	0	1	3	2	572	0	
11:45 AM	3	3	149	57	0	91	148	1	0	35	5	99	0	0	2	5	598	2,365	
12:00 PM	1	5	156	65	0	105	148	1	0	60	5	91	0	1	8	3	649	2,430	
12:15 PM	3	4	149	65	1	90	139	1	0	54	2	74	0	1	1	2	586	2,405	
12:30 PM	2	4	146	64	0	94	132	0	0	46	3	100	0	0	4	4	599	2,432	
12:45 PM	0	2	123	62	0	93	136	2	0	59	3	98	0	1	4	3	586	2,420	
Count Total	12	27	1,131	500	1	784	1,099	10	0	407	30	722	0	6	30	26	4,785	0	
Peak Hour	All	9	16	600	251	1	380	567	3	0	195	15	364	0	2	15	14	2,432	0
	HV	0	0	7	1	0	2	2	0	0	2	0	7	0	0	0	0	21	0
	HV%	0%	0%	1%	0%	0%	1%	0%	0%	-	1%	0%	2%	-	0%	0%	0%	1%	0

Note: Two-hour count summary volumes include heavy vehicles but exclude bicycles in overall count.

Interval Start	Heavy Vehicle Totals					Bicycles					Pedestrians (Crossing Leg)				
	EB	WB	NB	SB	Total	EB	WB	NB	SB	Total	East	West	North	South	Total
11:00 AM	2	1	1	0	4	0	3	0	0	3	0	0	0	1	1
11:15 AM	4	3	0	0	7	0	0	1	0	1	2	0	0	1	3
11:30 AM	2	2	3	0	7	0	0	0	0	0	2	0	0	0	2
11:45 AM	2	2	1	0	5	0	0	0	0	0	0	0	0	0	0
12:00 PM	2	1	2	0	5	0	0	0	0	0	0	0	0	0	0
12:15 PM	2	0	2	0	4	0	1	0	0	1	0	0	0	0	0
12:30 PM	2	1	4	0	7	0	0	0	0	0	0	0	0	1	1
12:45 PM	0	3	3	0	6	0	0	2	0	2	2	0	0	0	2
Count Total	16	13	16	0	45	0	4	3	0	7	6	0	0	3	9
Peak Hour	8	4	9	0	21	0	1	0	0	1	0	0	0	1	1

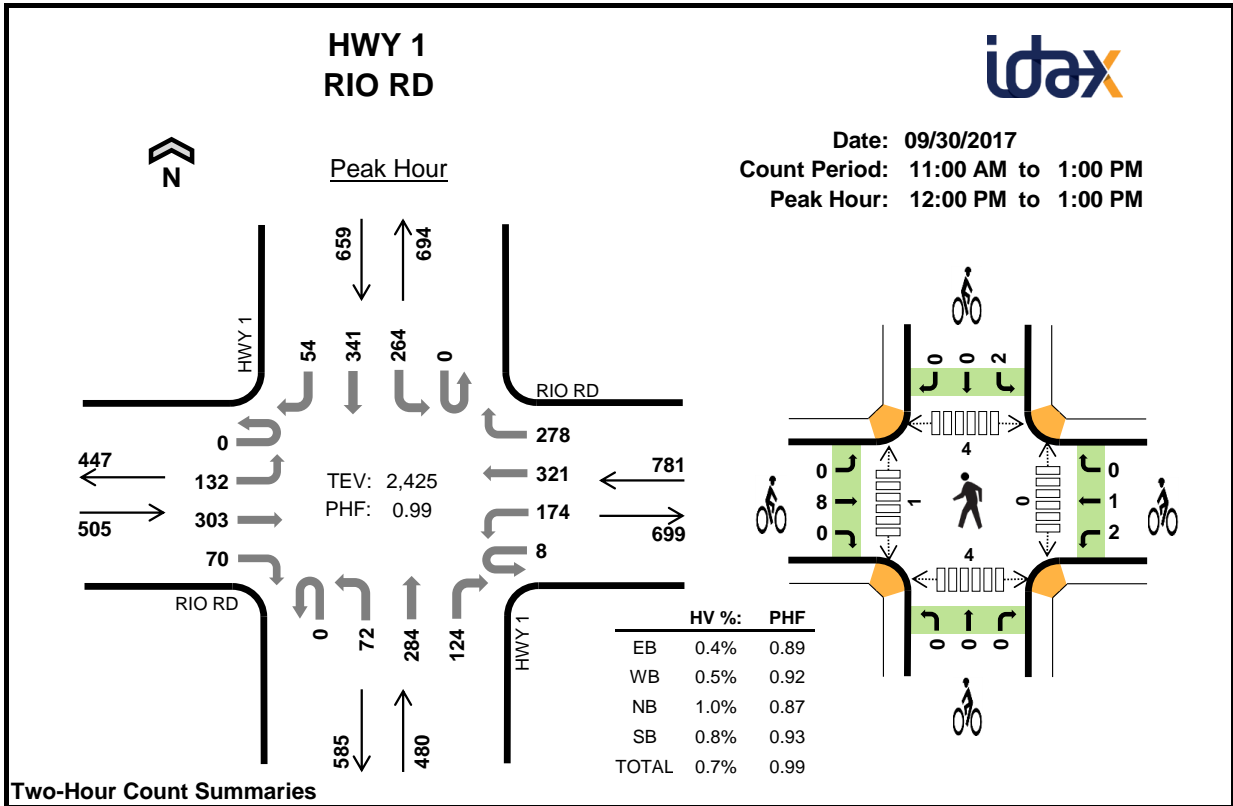

Two-Hour Count Summaries

Interval Start	RIO RD Eastbound				RIO RD Westbound				HWY 1 Northbound				HWY 1 Southbound				15-min Total	Rolling One Hour	
	UT	LT	TH	RT	UT	LT	TH	RT	UT	LT	TH	RT	UT	LT	TH	RT			
11:00 AM	0	22	69	15	3	37	67	79	0	13	60	40	0	72	92	17	586	0	
11:15 AM	0	30	69	30	2	39	67	71	0	13	65	31	0	71	90	24	602	0	
11:30 AM	0	35	77	19	2	28	68	64	0	21	53	34	0	69	89	17	576	0	
11:45 AM	0	35	87	18	2	32	55	67	0	23	57	31	0	64	91	14	576	2,340	
12:00 PM	0	29	96	17	3	43	67	60	0	8	67	30	0	68	91	18	597	2,351	
12:15 PM	0	25	72	20	4	45	83	75	0	26	72	40	0	66	69	10	607	2,356	
12:30 PM	0	41	69	16	1	48	75	65	0	22	72	26	0	73	82	16	606	2,386	
12:45 PM	0	37	66	17	0	38	96	78	0	16	73	28	0	57	99	10	615	2,425	
Count Total	0	254	605	152	17	310	578	559	0	142	519	260	0	540	703	126	4,765	0	
Peak Hour	All	0	132	303	70	8	174	321	278	0	72	284	124	0	264	341	54	2,425	0
	HV	0	1	1	0	0	0	2	2	0	0	5	0	0	1	2	2	16	0
	HV%	-	1%	0%	0%	0%	0%	1%	1%	-	0%	2%	0%	-	0%	1%	4%	1%	0

Note: Two-hour count summary volumes include heavy vehicles but exclude bicycles in overall count.

Interval Start	Heavy Vehicle Totals					Bicycles					Pedestrians (Crossing Leg)				
	EB	WB	NB	SB	Total	EB	WB	NB	SB	Total	East	West	North	South	Total
11:00 AM	2	2	4	0	8	0	2	0	0	2	0	1	2	2	5
11:15 AM	5	3	1	1	10	2	0	0	0	2	0	0	0	0	0
11:30 AM	1	2	1	1	5	0	0	0	0	0	0	2	1	1	4
11:45 AM	1	0	1	1	3	0	0	1	0	1	1	0	0	3	4
12:00 PM	0	3	0	1	4	0	2	0	2	4	0	1	1	1	3
12:15 PM	0	0	3	2	5	0	0	0	0	0	0	0	1	2	3
12:30 PM	1	1	0	1	3	5	0	0	0	5	0	0	1	0	1
12:45 PM	1	0	2	1	4	3	1	0	0	4	0	0	1	1	2
Count Total	11	11	12	8	42	10	5	1	2	18	1	4	7	10	22
Peak Hour	2	4	5	5	16	8	3	0	2	13	0	1	4	4	9

CROSSROADS BLVD RIO RD



Peak Hour

Date: 09/30/2017
Count Period: 11:00 AM to 1:00 PM
Peak Hour: 12:00 PM to 1:00 PM

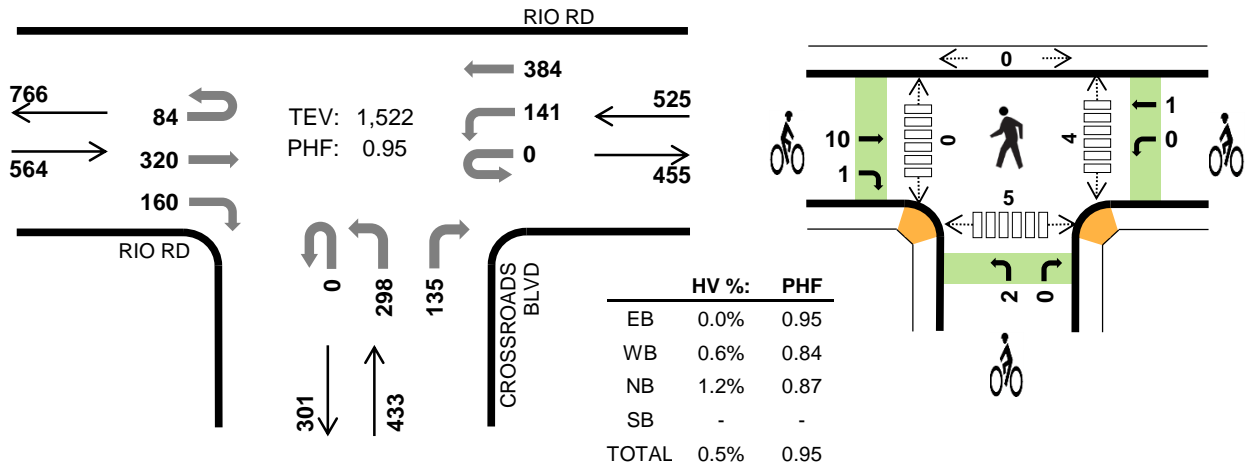

Two-Hour Count Summaries

Interval Start	RIO RD Eastbound				RIO RD Westbound				CROSSROADS BLVD Northbound				0 Southbound				15-min Total	Rolling One Hour	
	UT	LT	TH	RT	UT	LT	TH	RT	UT	LT	TH	RT	UT	LT	TH	RT			
11:00 AM	29	0	83	29	0	26	90	0	0	67	0	24	0	0	0	0	348	0	
11:15 AM	30	0	77	27	0	36	80	0	0	69	0	30	0	0	0	0	349	0	
11:30 AM	20	0	74	43	0	19	75	0	0	64	0	32	0	0	0	0	327	0	
11:45 AM	18	0	81	41	0	30	74	0	0	63	0	23	0	0	0	0	330	1,354	
12:00 PM	15	0	83	46	0	37	95	0	0	63	0	33	0	0	0	0	372	1,378	
12:15 PM	22	0	76	44	0	34	91	0	0	74	0	23	0	0	0	0	364	1,393	
12:30 PM	29	0	86	34	0	29	82	0	0	88	0	36	0	0	0	0	384	1,450	
12:45 PM	18	0	75	36	0	41	116	0	0	73	0	43	0	0	0	0	402	1,522	
Count Total	181	0	635	300	0	252	703	0	0	561	0	244	0	0	0	0	2,876	0	
Peak Hour	All	84	0	320	160	0	141	384	0	0	298	0	135	0	0	0	0	1,522	0
	HV	0	0	0	0	0	2	1	0	0	3	0	2	0	0	0	0	8	0
	HV%	0%	-	0%	0%	-	1%	0%	-	-	1%	-	1%	-	-	-	-	1%	0

Note: Two-hour count summary volumes include heavy vehicles but exclude bicycles in overall count.

Interval Start	Heavy Vehicle Totals					Bicycles					Pedestrians (Crossing Leg)				
	EB	WB	NB	SB	Total	EB	WB	NB	SB	Total	East	West	North	South	Total
11:00 AM	0	0	1	0	1	1	1	0	0	2	2	0	0	0	2
11:15 AM	1	3	2	0	6	1	0	0	0	1	0	0	0	0	
11:30 AM	1	0	5	0	6	0	0	0	0	0	1	0	0	1	
11:45 AM	1	1	0	0	2	0	0	0	0	0	0	0	0	0	
12:00 PM	0	1	2	0	3	2	0	2	0	4	2	0	0	2	
12:15 PM	0	0	0	0	0	0	0	0	0	0	1	0	0	1	
12:30 PM	0	1	2	0	3	5	0	0	0	5	1	0	0	3	
12:45 PM	0	1	1	0	2	4	1	0	0	5	0	0	0	0	
Count Total	3	7	13	0	23	13	2	2	0	17	7	0	0	6	
Peak Hr	0	3	5	0	8	11	1	2	0	14	4	0	0	5	

CARMEL CENTER PL RIO RD



Date: 09/30/2017
 Count Period: 11:00 AM to 1:00 PM
 Peak Hour: 12:00 PM to 1:00 PM

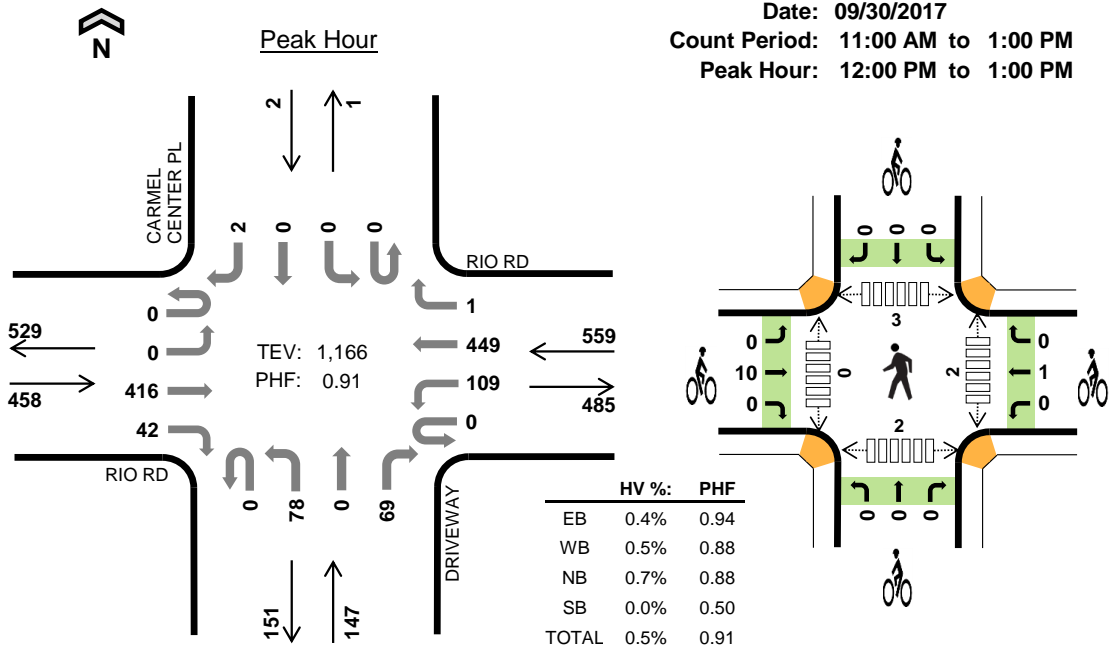

Two-Hour Count Summaries

Interval Start	RIO RD Eastbound				RIO RD Westbound				DRIVEWAY Northbound				CARMEL CENTER PL Southbound				15-min Total	Rolling One Hour	
	UT	LT	TH	RT	UT	LT	TH	RT	UT	LT	TH	RT	UT	LT	TH	RT			
11:00 AM	0	0	93	13	0	16	97	1	0	18	0	18	0	0	0	0	256	0	
11:15 AM	0	0	100	9	0	28	111	0	0	12	0	19	0	0	0	0	279	0	
11:30 AM	0	0	96	10	0	29	75	0	0	16	0	23	0	0	0	0	249	0	
11:45 AM	0	0	90	14	0	31	89	0	0	16	0	23	0	0	0	0	263	1,047	
12:00 PM	0	0	105	12	0	29	110	0	0	21	0	18	0	0	0	1	296	1,087	
12:15 PM	0	0	88	12	0	32	110	0	0	15	0	15	0	0	0	0	272	1,080	
12:30 PM	0	0	115	7	0	23	96	0	0	18	0	18	0	0	0	0	277	1,108	
12:45 PM	0	0	108	11	0	25	133	1	0	24	0	18	0	0	0	1	321	1,166	
Count Total	0	0	795	88	0	213	821	2	0	140	0	152	0	0	0	2	2,213	0	
Peak Hour	All	0	0	416	42	0	109	449	1	0	78	0	69	0	0	0	2	1,166	0
	HV	0	0	2	0	0	0	3	0	0	0	0	1	0	0	0	0	6	0
	HV%	-	-	0%	0%	-	0%	1%	0%	-	0%	-	1%	-	-	-	0%	1%	0

Note: Two-hour count summary volumes include heavy vehicles but exclude bicycles in overall count.

Interval Start	Heavy Vehicle Totals					Bicycles					Pedestrians (Crossing Leg)				
	EB	WB	NB	SB	Total	EB	WB	NB	SB	Total	East	West	North	South	Total
11:00 AM	0	2	0	0	2	1	1	0	0	2	1	0	0	0	1
11:15 AM	1	2	1	0	4	0	0	1	0	1	0	0	0	0	1
11:30 AM	4	1	1	0	6	0	0	0	0	0	0	0	1	0	1
11:45 AM	1	1	0	0	2	0	0	0	0	0	0	0	1	2	3
12:00 PM	0	1	1	0	2	2	0	0	0	2	0	0	2	1	3
12:15 PM	0	0	0	0	0	0	0	0	0	0	0	0	0	0	0
12:30 PM	1	1	0	0	2	5	0	0	0	5	2	0	1	0	3
12:45 PM	1	1	0	0	2	3	1	0	0	4	0	0	0	1	1
Count Total	8	9	3	0	20	11	2	1	0	14	3	0	5	5	13
Peak Hour	2	3	1	0	6	10	1	0	0	11	2	0	3	2	7

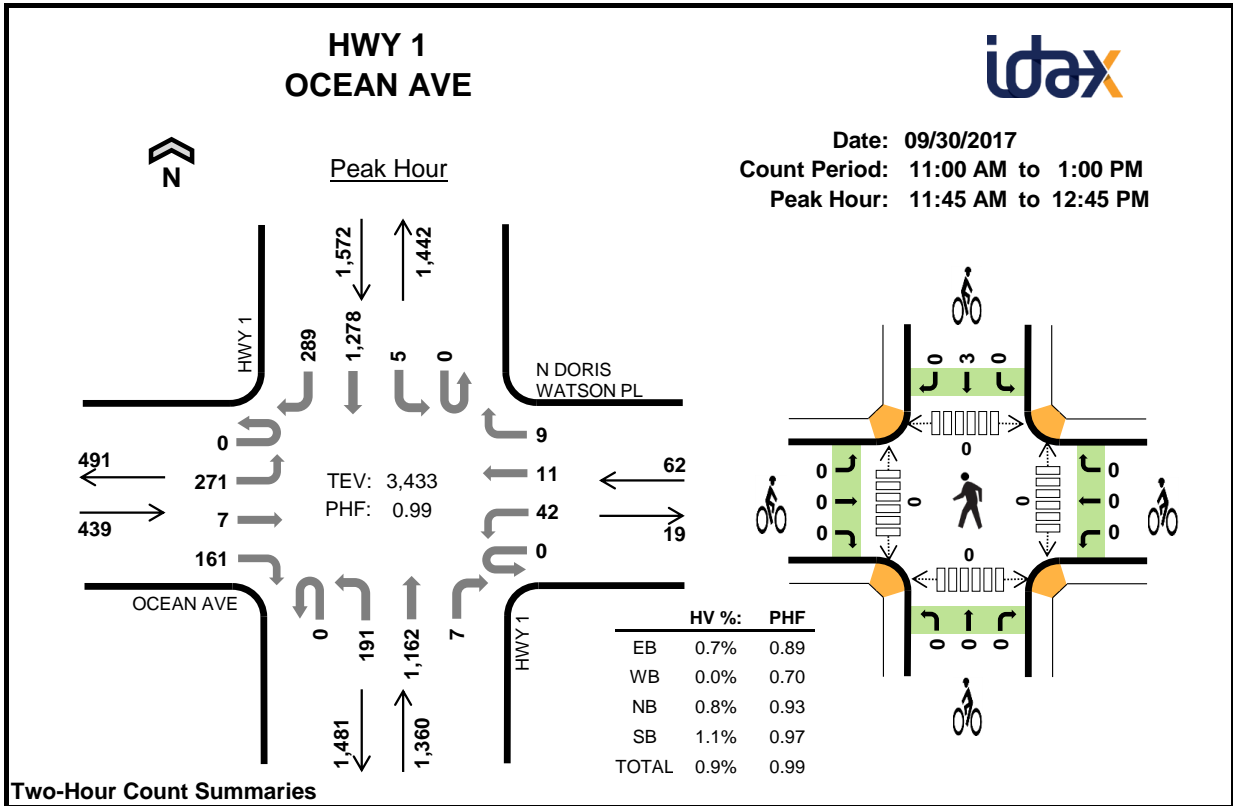

Two-Hour Count Summaries

Interval Start	OCEAN AVE				N DORIS WATSON PL				HWY 1				HWY 1				15-min Total	Rolling One Hour	
	Eastbound		Westbound		Northbound		Southbound		Northbound		Southbound		Southbound						
	UT	LT	TH	RT	UT	LT	TH	RT	UT	LT	TH	RT	UT	LT	TH	RT			
11:00 AM	0	69	1	61	0	17	1	13	0	39	267	2	0	0	318	84	872	0	
11:15 AM	0	55	2	41	0	7	3	10	0	32	308	3	0	1	351	76	889	0	
11:30 AM	0	78	4	43	0	3	5	5	0	42	245	3	0	2	288	98	816	0	
11:45 AM	0	66	2	47	0	16	2	4	0	46	263	1	0	0	340	61	848	3,425	
12:00 PM	0	71	1	37	0	11	1	1	0	37	305	1	0	0	319	85	869	3,422	
12:15 PM	0	60	1	30	0	8	2	2	0	57	308	2	0	1	302	75	848	3,381	
12:30 PM	0	74	3	47	0	7	6	2	0	51	286	3	0	4	317	68	868	3,433	
12:45 PM	0	72	2	36	0	9	3	2	0	52	289	2	0	2	302	61	832	3,417	
Count Total	0	545	16	342	0	78	23	39	0	356	2,271	17	0	10	2,537	608	6,842	0	
Peak Hour	All	0	271	7	161	0	42	11	9	0	191	1,162	7	0	5	1,278	289	3,433	0
	HV	0	3	0	0	0	0	0	0	0	1	9	1	0	0	17	1	32	0
	HV%	-	1%	0%	0%	-	0%	0%	0%	-	1%	1%	14%	-	0%	1%	0%	1%	0

Note: Two-hour count summary volumes include heavy vehicles but exclude bicycles in overall count.

Interval Start	Heavy Vehicle Totals					Bicycles					Pedestrians (Crossing Leg)				
	EB	WB	NB	SB	Total	EB	WB	NB	SB	Total	East	West	North	South	Total
11:00 AM	3	0	4	0	7	0	0	0	0	0	0	0	0	0	0
11:15 AM	0	0	3	7	10	0	0	0	0	0	0	0	0	2	2
11:30 AM	0	1	2	1	4	0	0	0	0	0	0	0	0	0	0
11:45 AM	1	0	3	4	8	0	0	0	0	0	0	0	0	0	0
12:00 PM	0	0	3	3	6	0	0	0	2	2	0	0	0	0	0
12:15 PM	1	0	4	6	11	0	0	0	0	0	0	0	0	0	0
12:30 PM	1	0	1	5	7	0	0	0	1	1	0	0	0	0	0
12:45 PM	0	0	6	2	8	0	0	0	0	0	0	0	0	0	0
Count Total	6	1	26	28	61	0	0	0	3	3	0	0	0	2	2
Peak Hour	3	0	11	18	32	0	0	0	3	3	0	0	0	0	0

HWY 1 CARPENTER ST



Peak Hour

Date: 09/30/2017
Count Period: 11:00 AM to 1:00 PM
Peak Hour: 11:15 AM to 12:15 PM

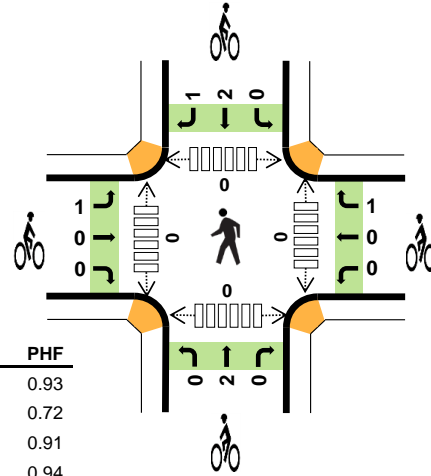
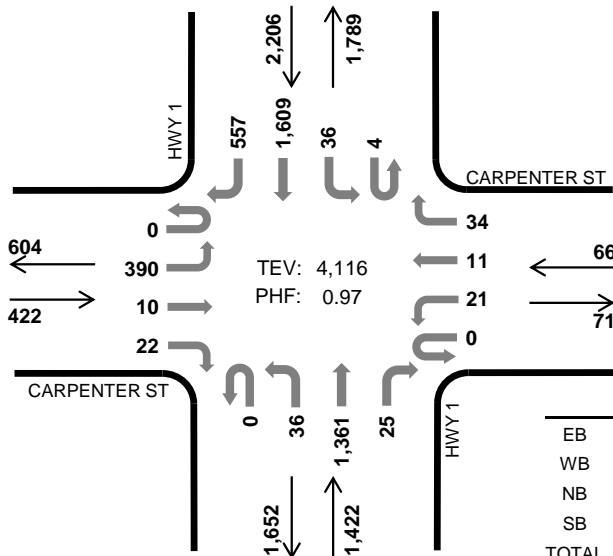

	HV %:	PHF
EB	1.7%	0.93
WB	0.0%	0.72
NB	0.8%	0.91
SB	1.0%	0.94
TOTAL	1.0%	0.97

Two-Hour Count Summaries

Interval Start	CARPENTER ST Eastbound				CARPENTER ST Westbound				HWY 1 Northbound				HWY 1 Southbound				15-min Total	Rolling One Hour	
	UT	LT	TH	RT	UT	LT	TH	RT	UT	LT	TH	RT	UT	LT	TH	RT			
11:00 AM	0	91	1	5	0	1	0	5	0	11	326	1	1	6	375	120	943	0	
11:15 AM	0	88	1	4	0	5	1	7	0	8	359	6	1	12	430	141	1,063	0	
11:30 AM	0	98	2	5	0	9	2	12	0	3	317	10	1	9	418	153	1,039	0	
11:45 AM	0	102	2	6	0	2	4	6	0	13	314	3	2	5	366	151	976	4,021	
12:00 PM	0	102	5	7	0	5	4	9	0	12	371	6	0	10	395	112	1,038	4,116	
12:15 PM	0	86	1	6	0	4	3	7	0	3	357	8	1	11	438	114	1,039	4,092	
12:30 PM	0	97	3	10	0	5	1	5	0	8	349	3	3	7	349	120	960	4,013	
12:45 PM	0	96	2	6	0	5	2	12	0	6	348	6	2	8	362	158	1,013	4,050	
Count Total	0	760	17	49	0	36	17	63	0	64	2,741	43	11	68	3,133	1,069	8,071	0	
Peak Hour	All	0	390	10	22	0	21	11	34	0	36	1,361	25	4	36	1,609	557	4,116	0
	HV	0	7	0	0	0	0	0	0	0	0	12	0	0	0	15	7	41	0
	HV%	-	2%	0%	0%	-	0%	0%	0%	-	0%	1%	0%	0%	0%	1%	1%	1%	0

Note: Two-hour count summary volumes include heavy vehicles but exclude bicycles in overall count.

Interval Start	Heavy Vehicle Totals					Bicycles					Pedestrians (Crossing Leg)				
	EB	WB	NB	SB	Total	EB	WB	NB	SB	Total	East	West	North	South	Total
11:00 AM	0	0	6	1	7	0	0	0	0	0	0	0	0	0	0
11:15 AM	0	0	4	10	14	1	1	0	1	3	0	0	0	0	0
11:30 AM	4	0	2	3	9	0	0	0	0	0	0	0	0	0	0
11:45 AM	1	0	3	5	9	0	0	2	0	2	0	0	0	0	0
12:00 PM	2	0	3	4	9	0	0	0	2	2	0	0	0	0	0
12:15 PM	1	0	4	8	13	0	0	0	0	0	0	0	0	0	0
12:30 PM	1	0	2	6	9	0	0	0	1	1	0	0	0	0	0
12:45 PM	4	0	4	9	17	0	0	0	0	0	0	0	0	0	0
Count Total	13	0	28	46	87	1	1	2	4	8	0	0	0	0	0
Peak Hour	7	0	12	22	41	1	1	2	3	7	0	0	0	0	0

CARMEL RANCHO BLVD CLOCKTOWER DR



Date: 09/30/2017
 Count Period: 11:00 AM to 1:00 PM
 Peak Hour: 12:00 PM to 1:00 PM

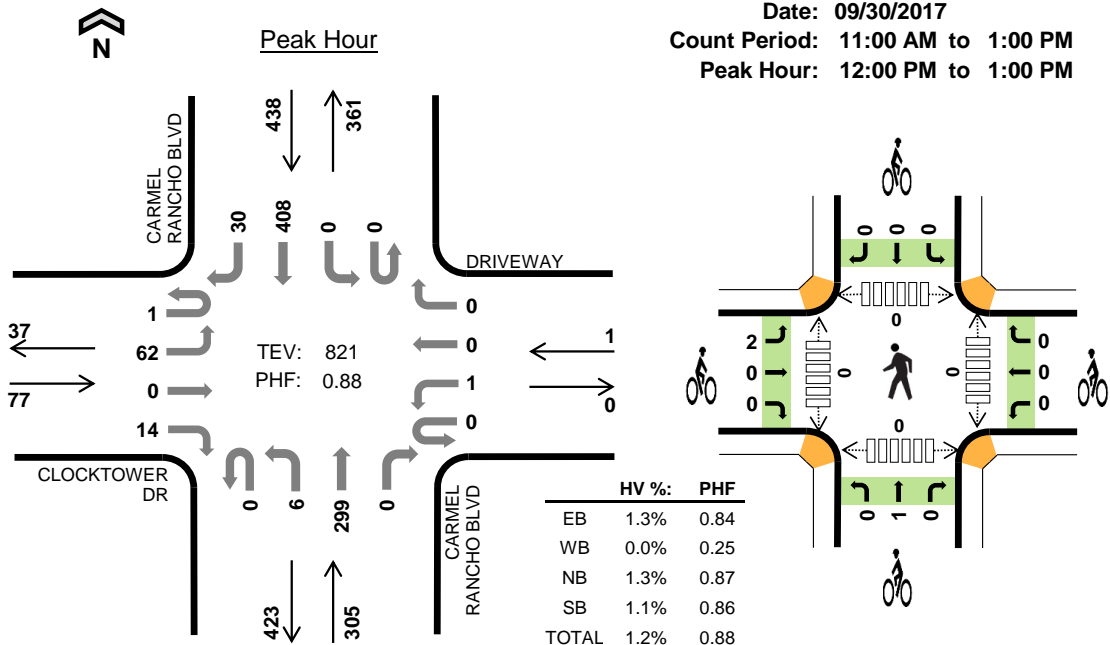

Two-Hour Count Summaries

Interval Start	CLOCKTOWER DR				DRIVEWAY				CARMEL RANCHO BLVD				CARMEL RANCHO BLVD				15-min Total	Rolling One Hour	
	Eastbound		Westbound		Northbound		Southbound		UT	LT	TH	RT	UT	LT	TH	RT			
11:00 AM	0	16	0	2	0	0	0	0	0	2	65	0	0	0	97	11	193	0	
11:15 AM	0	22	0	2	0	0	0	0	0	0	70	0	0	0	116	8	218	0	
11:30 AM	0	17	0	3	0	0	0	0	0	2	77	0	0	0	79	7	185	0	
11:45 AM	0	21	0	3	0	1	0	0	0	0	68	0	0	0	80	6	179	775	
12:00 PM	0	18	0	5	0	0	0	0	0	2	80	0	0	0	119	8	232	814	
12:15 PM	0	14	0	3	0	0	0	0	0	0	61	0	0	0	85	5	168	764	
12:30 PM	1	13	0	2	0	1	0	0	0	4	84	0	0	0	95	9	209	788	
12:45 PM	0	17	0	4	0	0	0	0	0	0	74	0	0	0	109	8	212	821	
Count Total	1	138	0	24	0	2	0	0	0	10	579	0	0	0	780	62	1,596	0	
Peak Hour	All	1	62	0	14	0	1	0	0	0	6	299	0	0	0	408	30	821	0
	HV	0	1	0	0	0	0	0	0	0	0	4	0	0	0	4	1	10	0
	HV%	0%	2%	-	0%	-	0%	-	-	-	0%	1%	-	-	-	1%	3%	1%	0

Note: Two-hour count summary volumes include heavy vehicles but exclude bicycles in overall count.

Interval Start	Heavy Vehicle Totals					Bicycles					Pedestrians (Crossing Leg)				
	EB	WB	NB	SB	Total	EB	WB	NB	SB	Total	East	West	North	South	Total
11:00 AM	0	0	0	1	1	0	0	0	1	1	0	0	0	0	0
11:15 AM	1	0	0	2	3	0	0	1	0	1	0	0	0	0	0
11:30 AM	0	0	2	0	2	0	0	0	0	0	0	0	0	0	0
11:45 AM	0	0	0	0	0	0	0	0	0	0	0	0	0	0	0
12:00 PM	0	0	1	1	2	2	0	0	0	2	0	0	0	0	0
12:15 PM	1	0	1	0	2	0	0	0	0	0	0	0	0	0	0
12:30 PM	0	0	1	3	4	0	0	0	0	0	0	0	0	0	0
12:45 PM	0	0	1	1	2	0	0	1	0	1	0	0	0	0	0
Count Total	2	0	6	8	16	2	0	2	1	5	0	0	0	0	0
Peak Hour	1	0	4	5	10	2	0	1	0	3	0	0	0	0	0

VIA NONA MARIE RIO RD



Date: 09/30/2017
 Count Period: 11:00 AM to 1:00 PM
 Peak Hour: 12:00 PM to 1:00 PM

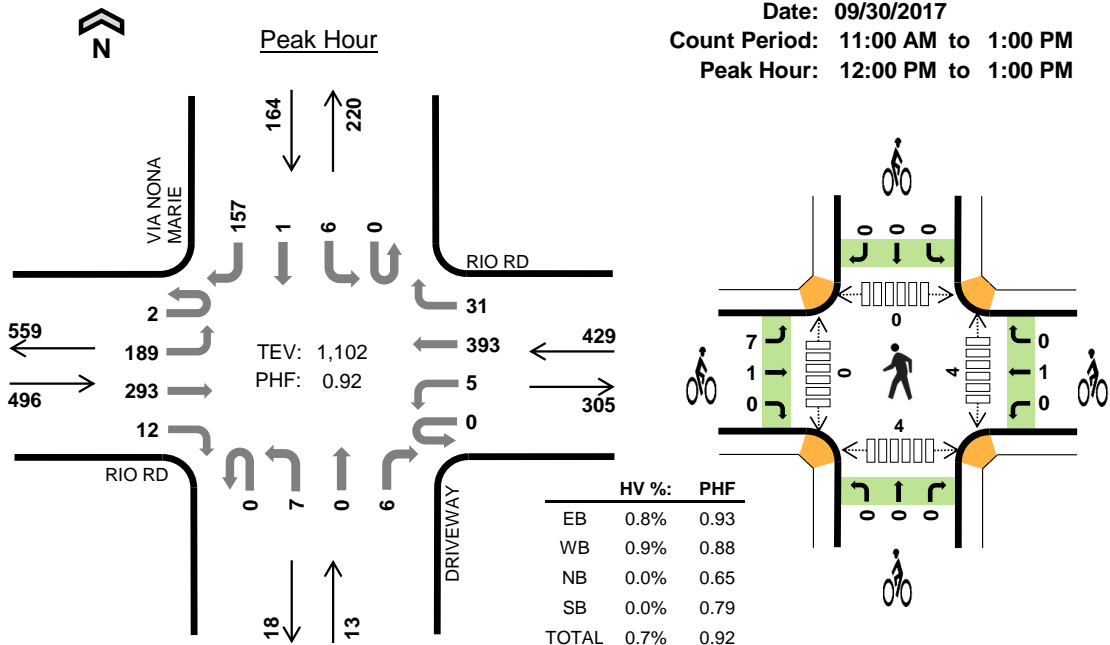

Two-Hour Count Summaries

Interval Start	RIO RD Eastbound				RIO RD Westbound				DRIVEWAY Northbound				VIA NONA MARIE Southbound				15-min Total	Rolling One Hour	
	UT	LT	TH	RT	UT	LT	TH	RT	UT	LT	TH	RT	UT	LT	TH	RT			
11:00 AM	0	42	62	2	0	0	81	8	0	4	0	1	0	2	1	31	234	0	
11:15 AM	0	41	71	4	1	2	104	12	0	1	0	1	0	0	0	27	264	0	
11:30 AM	0	41	72	2	1	1	73	5	0	1	0	2	0	0	1	31	230	0	
11:45 AM	0	49	67	6	0	1	83	0	0	2	1	3	0	1	0	36	249	977	
12:00 PM	0	48	72	5	0	1	99	10	0	2	0	1	0	1	0	36	275	1,018	
12:15 PM	1	46	65	2	0	2	96	6	0	3	0	2	0	1	0	40	264	1,018	
12:30 PM	1	43	85	5	0	0	87	6	0	2	0	2	0	3	1	30	265	1,053	
12:45 PM	0	52	71	0	0	2	111	9	0	0	0	1	0	1	0	51	298	1,102	
Count Total	2	362	565	26	2	9	734	56	0	15	1	13	0	9	3	282	2,079	0	
Peak Hour	All	2	189	293	12	0	5	393	31	0	7	0	6	0	6	1	157	1,102	0
	HV	0	1	3	0	0	0	4	0	0	0	0	0	0	0	0	0	8	0
	HV%	0%	1%	1%	0%	-	0%	1%	0%	-	0%	-	0%	-	0%	0%	0%	1%	0

Note: Two-hour count summary volumes include heavy vehicles but exclude bicycles in overall count.

Interval Start	Heavy Vehicle Totals					Bicycles					Pedestrians (Crossing Leg)				
	EB	WB	NB	SB	Total	EB	WB	NB	SB	Total	East	West	North	South	Total
11:00 AM	0	1	0	0	1	0	1	0	0	1	2	0	3	2	7
11:15 AM	0	2	0	0	2	1	0	0	0	1	1	0	0	1	2
11:30 AM	3	0	0	1	4	0	0	0	0	0	0	0	1	1	2
11:45 AM	2	0	0	0	2	0	0	0	0	0	1	0	0	2	3
12:00 PM	1	1	0	0	2	0	0	0	0	0	1	0	0	1	2
12:15 PM	1	0	0	0	1	2	0	0	0	2	0	0	0	0	0
12:30 PM	1	1	0	0	2	5	0	0	0	5	0	0	0	0	0
12:45 PM	1	2	0	0	3	1	1	0	0	2	3	0	0	3	6
Count Total	9	7	0	1	17	9	2	0	0	11	8	0	4	10	22
Peak Hour	4	4	0	0	8	8	1	0	0	9	4	0	0	4	8

RANCHO SAN CARLOS RD CARMEL VALLEY RD



Peak Hour

Date: 11/02/2017
Count Period: 7:00 AM to 9:00 AM
Peak Hour: 7:30 AM to 8:30 AM

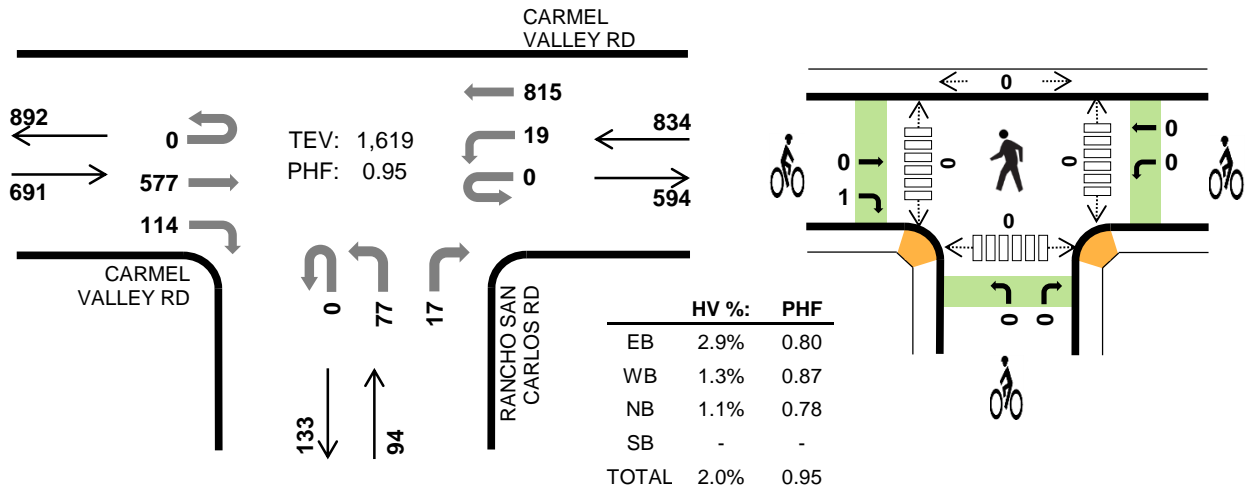

Two-Hour Count Summaries

Interval Start	CARMEL VALLEY RD Eastbound				CARMEL VALLEY RD Westbound				RANCHO SAN CARLOS RD Northbound				0 Southbound				15-min Total	Rolling One Hour	
	UT	LT	TH	RT	UT	LT	TH	RT	UT	LT	TH	RT	UT	LT	TH	RT			
7:00 AM	0	0	66	20	0	7	107	0	0	9	0	1	0	0	0	0	210	0	
7:15 AM	0	0	74	20	0	7	232	0	0	22	0	4	0	0	0	0	359	0	
7:30 AM	0	0	137	27	0	2	239	0	0	19	0	4	0	0	0	0	428	0	
7:45 AM	0	0	187	28	0	7	185	0	0	14	0	3	0	0	0	0	424	1,421	
8:00 AM	0	0	130	31	0	8	205	0	0	25	0	5	0	0	0	0	404	1,615	
8:15 AM	0	0	123	28	0	2	186	0	0	19	0	5	0	0	0	0	363	1,619	
8:30 AM	0	0	146	40	0	9	196	0	0	14	0	2	0	0	0	0	407	1,598	
8:45 AM	0	0	135	41	0	5	205	0	0	23	0	0	0	0	0	0	409	1,583	
Count Total	0	0	998	235	0	47	1,555	0	0	145	0	24	0	0	0	0	3,004	0	
Peak Hour	All	0	0	577	114	0	19	815	0	0	77	0	17	0	0	0	0	1,619	0
	HV	0	0	16	4	0	0	11	0	0	0	0	1	0	0	0	0	32	0
	HV%	-	-	3%	4%	-	0%	1%	-	-	0%	-	6%	-	-	-	-	2%	0

Note: Two-hour count summary volumes include heavy vehicles but exclude bicycles in overall count.

Interval Start	Heavy Vehicle Totals					Bicycles					Pedestrians (Crossing Leg)				
	EB	WB	NB	SB	Total	EB	WB	NB	SB	Total	East	West	North	South	Total
7:00 AM	4	2	0	0	6	0	0	0	0	0	0	0	0	0	0
7:15 AM	3	8	1	0	12	0	0	0	0	0	0	0	0	0	0
7:30 AM	3	2	0	0	5	0	0	0	0	0	0	0	0	0	0
7:45 AM	8	3	1	0	12	0	0	0	0	0	0	0	0	0	0
8:00 AM	4	2	0	0	6	1	0	0	0	1	0	0	0	0	0
8:15 AM	5	4	0	0	9	0	0	0	0	0	0	0	0	0	0
8:30 AM	4	3	1	0	8	0	0	0	0	0	1	0	0	0	1
8:45 AM	7	6	0	0	13	0	0	0	0	0	0	0	0	0	0
Count Total	38	30	3	0	71	1	0	0	0	1	1	0	0	0	1
Peak Hr	20	11	1	0	32	1	0	0	0	1	0	0	0	0	0

RANCHO SAN CARLOS RD CARMEL VALLEY RD



Peak Hour

Date: 11/02/2017
Count Period: 4:00 PM to 6:00 PM
Peak Hour: 4:15 PM to 5:15 PM

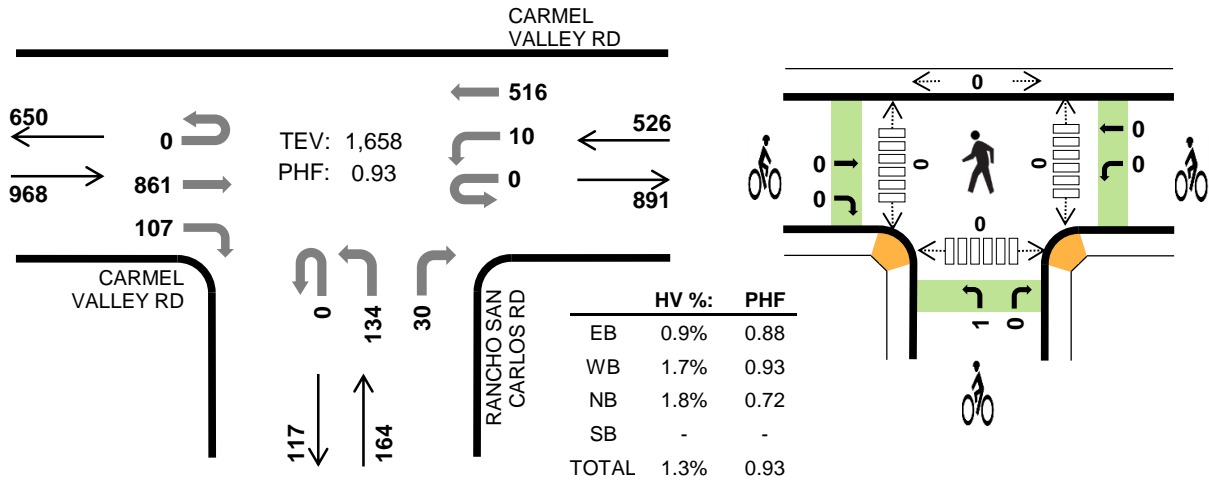

Two-Hour Count Summaries

Interval Start	CARMEL VALLEY RD Eastbound				CARMEL VALLEY RD Westbound				RANCHO SAN CARLOS RD Northbound				0 Southbound				15-min Total	Rolling One Hour	
	UT	LT	TH	RT	UT	LT	TH	RT	UT	LT	TH	RT	UT	LT	TH	RT			
4:00 PM	0	0	211	27	0	0	143	0	0	46	0	16	0	0	0	0	443	0	
4:15 PM	0	0	229	24	0	2	116	0	0	39	0	6	0	0	0	0	416	0	
4:30 PM	0	0	197	29	0	3	137	0	0	22	0	7	0	0	0	0	395	0	
4:45 PM	0	0	184	31	0	4	123	0	0	45	0	12	0	0	0	0	399	1,653	
5:00 PM	0	0	251	23	0	1	140	0	0	28	0	5	0	0	0	0	448	1,658	
5:15 PM	0	0	229	17	0	1	112	0	0	37	0	7	0	0	0	0	403	1,645	
5:30 PM	0	0	204	21	0	3	126	0	0	23	0	3	0	0	0	0	380	1,630	
5:45 PM	0	0	177	26	0	3	112	0	0	28	0	8	0	0	0	0	354	1,585	
Count Total	0	0	1,682	198	0	17	1,009	0	0	268	0	64	0	0	0	0	3,238	0	
Peak Hour	All	0	0	861	107	0	10	516	0	0	134	0	30	0	0	0	0	1,658	0
	HV	0	0	8	1	0	0	9	0	0	3	0	0	0	0	0	0	21	0
	HV%	-	-	1%	1%	-	0%	2%	-	-	2%	-	0%	-	-	-	-	1%	0

Note: Two-hour count summary volumes include heavy vehicles but exclude bicycles in overall count.

Interval Start	Heavy Vehicle Totals					Bicycles					Pedestrians (Crossing Leg)				
	EB	WB	NB	SB	Total	EB	WB	NB	SB	Total	East	West	North	South	Total
4:00 PM	3	1	1	0	5	0	0	0	0	0	0	0	0	0	0
4:15 PM	0	2	2	0	4	0	0	1	0	1	0	0	0	0	0
4:30 PM	5	2	0	0	7	0	0	0	0	0	0	0	0	0	0
4:45 PM	2	1	1	0	4	0	0	0	0	0	0	0	0	0	0
5:00 PM	2	4	0	0	6	0	0	0	0	0	0	0	0	0	0
5:15 PM	3	1	0	0	4	0	0	0	0	0	0	0	0	0	0
5:30 PM	7	2	0	0	9	0	0	0	0	0	0	0	0	0	0
5:45 PM	3	3	0	0	6	0	0	0	0	0	0	0	0	0	0
Count Total	25	16	4	0	45	0	0	1	0	1	0	0	0	0	0
Peak Hr	9	9	3	0	21	0	0	1	0	1	0	0	0	0	0

RANCHO SAN CARLOS RD CARMEL VALLEY RD



Peak Hour

Date: 11/04/2017
Count Period: 11:00 AM to 1:00 PM
Peak Hour: 11:30 AM to 12:30 PM

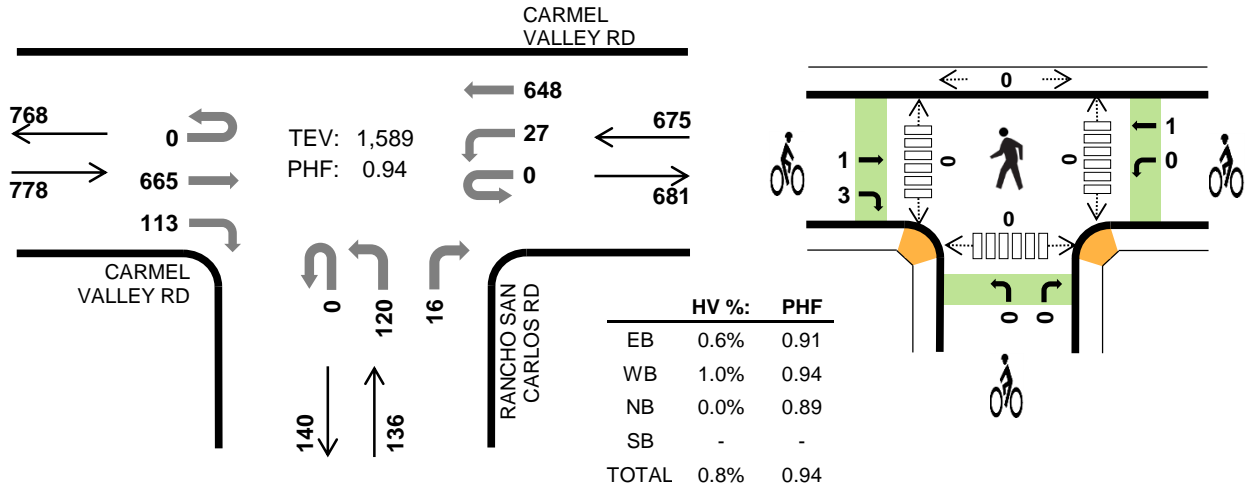

Two-Hour Count Summaries

Interval Start	CARMEL VALLEY RD Eastbound				CARMEL VALLEY RD Westbound				RANCHO SAN CARLOS RD Northbound				0 Southbound				15-min Total	Rolling One Hour	
	UT	LT	TH	RT	UT	LT	TH	RT	UT	LT	TH	RT	UT	LT	TH	RT			
11:00 AM	0	0	155	28	0	4	144	0	0	30	0	10	0	0	0	0	371	0	
11:15 AM	0	0	153	15	0	7	135	0	0	37	0	0	0	0	0	0	347	0	
11:30 AM	0	0	163	40	0	9	171	0	0	33	0	5	0	0	0	0	421	0	
11:45 AM	0	0	185	28	0	7	166	0	0	22	0	5	0	0	0	0	413	1,552	
12:00 PM	0	0	173	26	0	7	158	0	0	31	0	3	0	0	0	0	398	1,579	
12:15 PM	0	0	144	19	0	4	153	0	0	34	0	3	0	0	0	0	357	1,589	
12:30 PM	0	0	149	30	0	4	125	0	0	26	0	3	0	0	0	0	337	1,505	
12:45 PM	0	0	177	28	0	2	160	0	0	24	0	7	0	0	0	0	398	1,490	
Count Total	0	0	1,299	214	0	44	1,212	0	0	237	0	36	0	0	0	0	3,042	0	
Peak Hour	All	0	0	665	113	0	27	648	0	0	120	0	16	0	0	0	0	1,589	0
	HV	0	0	5	0	0	1	6	0	0	0	0	0	0	0	0	0	12	0
	HV%	-	-	1%	0%	-	4%	1%	-	-	0%	-	0%	-	-	-	-	1%	0

Note: Two-hour count summary volumes include heavy vehicles but exclude bicycles in overall count.

Interval Start	Heavy Vehicle Totals					Bicycles					Pedestrians (Crossing Leg)				
	EB	WB	NB	SB	Total	EB	WB	NB	SB	Total	East	West	North	South	Total
11:00 AM	1	1	0	0	2	1	0	0	0	1	0	0	0	0	0
11:15 AM	5	1	0	0	6	0	0	1	0	1	0	0	0	0	0
11:30 AM	2	1	0	0	3	1	1	0	0	2	0	0	0	0	0
11:45 AM	1	2	0	0	3	0	0	0	0	0	0	0	0	0	0
12:00 PM	0	2	0	0	2	1	0	0	0	1	0	0	0	0	0
12:15 PM	2	2	0	0	4	2	0	0	0	2	0	0	0	0	0
12:30 PM	1	0	1	0	2	1	0	0	0	1	0	0	0	0	0
12:45 PM	3	0	1	0	4	2	1	0	0	3	0	0	0	0	0
Count Total	15	9	2	0	26	8	2	1	0	11	0	0	0	0	0
Peak Hr	5	7	0	0	12	4	1	0	0	5	0	0	0	0	0

VALLEY GREENS DR CARMEL VALLEY RD



Date: 11/02/2017
 Count Period: 7:00 AM to 9:00 AM
 Peak Hour: 7:15 AM to 8:15 AM

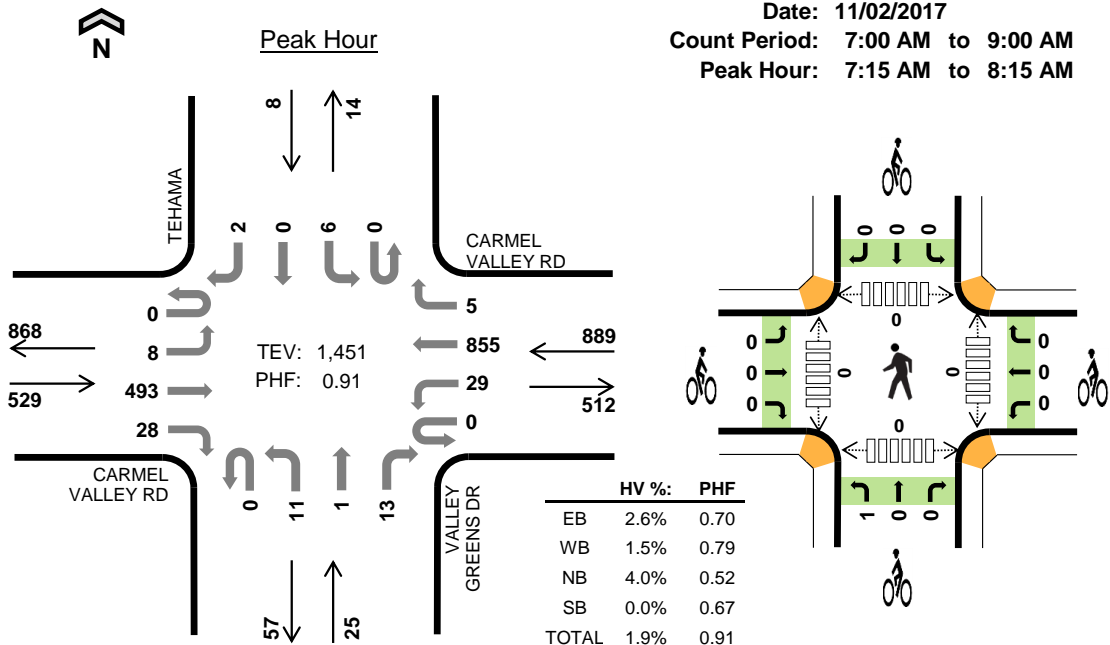

Two-Hour Count Summaries

Interval Start	CARMEL VALLEY RD				CARMEL VALLEY RD				VALLEY GREENS DR				TEHAMA				15-min Total	Rolling One Hour	
	Eastbound		Westbound		Northbound		Southbound		UT	LT	TH	RT	UT	LT	TH	RT			
7:00 AM	0	0	64	4	0	5	114	2	0	2	0	3	0	0	0	1	195	0	
7:15 AM	0	1	70	3	0	7	272	1	0	1	0	2	0	2	0	0	359	0	
7:30 AM	0	1	130	7	0	5	193	2	0	2	0	3	0	1	0	1	345	0	
7:45 AM	0	3	178	8	0	8	187	0	0	7	1	4	0	1	0	0	397	1,296	
8:00 AM	0	3	115	10	0	9	203	2	0	1	0	4	0	2	0	1	350	1,451	
8:15 AM	0	2	118	3	0	7	171	2	0	4	0	5	0	2	0	2	316	1,408	
8:30 AM	0	2	131	9	0	7	197	3	0	3	0	5	0	2	0	3	362	1,425	
8:45 AM	0	1	130	3	0	5	201	2	0	6	0	8	0	1	0	1	358	1,386	
Count Total	0	13	936	47	0	53	1,538	14	0	26	1	34	0	11	0	9	2,682	0	
Peak Hour	All	0	8	493	28	0	29	855	5	0	11	1	13	0	6	0	2	1,451	0
	HV	0	0	13	1	0	1	12	0	0	0	1	0	0	0	0	0	28	0
	HV%	-	0%	3%	4%	-	3%	1%	0%	-	0%	100%	0%	-	0%	-	0%	2%	0

Note: Two-hour count summary volumes include heavy vehicles but exclude bicycles in overall count.

Interval Start	Heavy Vehicle Totals					Bicycles					Pedestrians (Crossing Leg)				
	EB	WB	NB	SB	Total	EB	WB	NB	SB	Total	East	West	North	South	Total
7:00 AM	3	5	0	0	8	0	0	0	0	0	0	0	0	0	0
7:15 AM	2	5	0	0	7	0	0	0	0	0	0	0	0	0	0
7:30 AM	2	5	0	0	7	0	0	0	0	0	0	0	0	0	0
7:45 AM	7	1	1	0	9	0	0	1	0	1	0	0	0	0	0
8:00 AM	3	2	0	0	5	0	0	0	0	0	0	0	0	0	0
8:15 AM	4	3	0	0	7	0	0	0	0	0	0	0	0	0	0
8:30 AM	3	4	0	0	7	0	0	0	0	0	0	0	0	0	0
8:45 AM	6	6	1	0	13	0	0	0	0	0	0	0	0	0	0
Count Total	30	31	2	0	63	0	0	1	0	1	0	0	0	0	0
Peak Hour	14	13	1	0	28	0	0	1	0	1	0	0	0	0	0

VALLEY GREENS DR CARMEL VALLEY RD



Peak Hour

Date: 11/02/2017
Count Period: 4:00 PM to 6:00 PM
Peak Hour: 4:15 PM to 5:15 PM

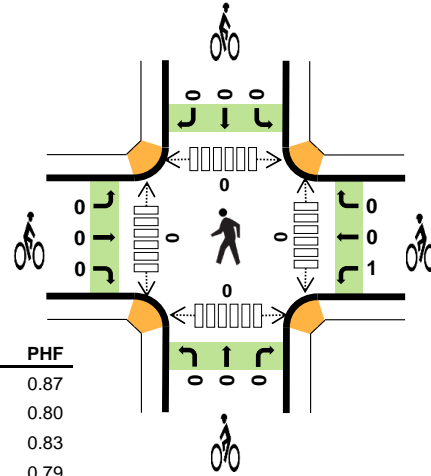
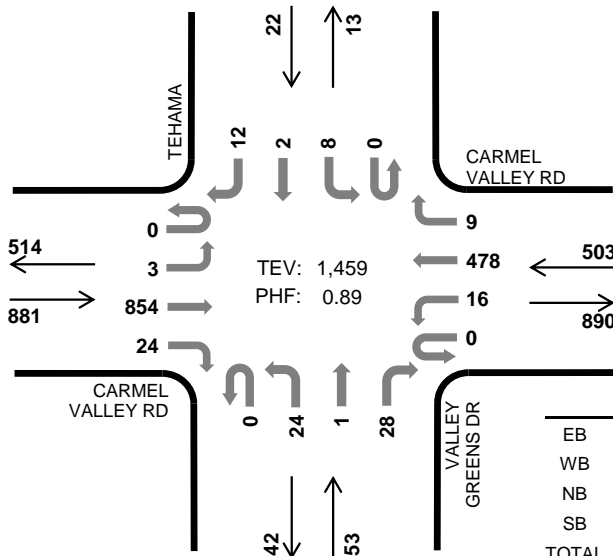

	HV %:	PHF
EB	0.9%	0.87
WB	2.0%	0.80
NB	0.0%	0.83
SB	0.0%	0.79
TOTAL	1.2%	0.89

Two-Hour Count Summaries

Interval Start	CARMEL VALLEY RD				CARMEL VALLEY RD				VALLEY GREENS DR				TEHAMA				15-min Total	Rolling One Hour	
	Eastbound		Westbound		Northbound		Southbound		UT	LT	TH	RT	UT	LT	TH	RT			
4:00 PM	0	0	208	9	0	3	124	2	0	5	0	5	0	3	0	2	361	0	
4:15 PM	0	1	231	3	0	5	95	4	0	6	0	5	0	3	1	2	356	0	
4:30 PM	0	0	198	9	0	6	149	2	0	9	1	6	0	2	0	1	383	0	
4:45 PM	0	1	179	5	0	2	102	2	0	3	0	12	0	1	0	5	312	1,412	
5:00 PM	0	1	246	7	0	3	132	1	0	6	0	5	0	2	1	4	408	1,459	
5:15 PM	0	0	224	5	0	2	110	2	0	4	0	4	0	1	0	1	353	1,456	
5:30 PM	0	1	198	5	0	1	121	7	0	2	1	10	0	0	0	0	346	1,419	
5:45 PM	0	1	175	6	0	5	95	1	0	5	0	5	0	1	0	1	295	1,402	
Count Total	0	5	1,659	49	0	27	928	21	0	40	2	52	0	13	2	16	2,814	0	
Peak Hour	All	0	3	854	24	0	16	478	9	0	24	1	28	0	8	2	12	1,459	0
	HV	0	0	8	0	0	0	10	0	0	0	0	0	0	0	0	0	18	0
	HV%	-	0%	1%	0%	-	0%	2%	0%	-	0%	0%	0%	-	0%	0%	0%	1%	0

Note: Two-hour count summary volumes include heavy vehicles but exclude bicycles in overall count.

Interval Start	Heavy Vehicle Totals					Bicycles					Pedestrians (Crossing Leg)				
	EB	WB	NB	SB	Total	EB	WB	NB	SB	Total	East	West	North	South	Total
4:00 PM	3	1	0	0	4	0	0	0	0	0	0	0	0	0	0
4:15 PM	0	2	0	0	2	0	0	0	0	0	0	0	0	0	0
4:30 PM	4	2	0	0	6	0	0	0	0	0	0	0	0	0	0
4:45 PM	2	2	0	0	4	0	1	0	0	1	0	0	0	0	0
5:00 PM	2	4	0	0	6	0	0	0	0	0	0	0	0	0	0
5:15 PM	3	2	0	0	5	0	0	1	0	1	0	0	0	0	0
5:30 PM	6	2	0	0	8	0	0	0	0	0	0	0	0	0	0
5:45 PM	4	1	0	0	5	0	0	0	0	0	0	0	0	0	0
Count Total	24	16	0	0	40	0	1	1	0	2	0	0	0	0	0
Peak Hour	8	10	0	0	18	0	1	0	0	1	0	0	0	0	0

VALLEY GREENS DR CARMEL VALLEY RD



Date: 11/04/2017
 Count Period: 11:00 AM to 1:00 PM
 Peak Hour: 11:15 AM to 12:15 PM

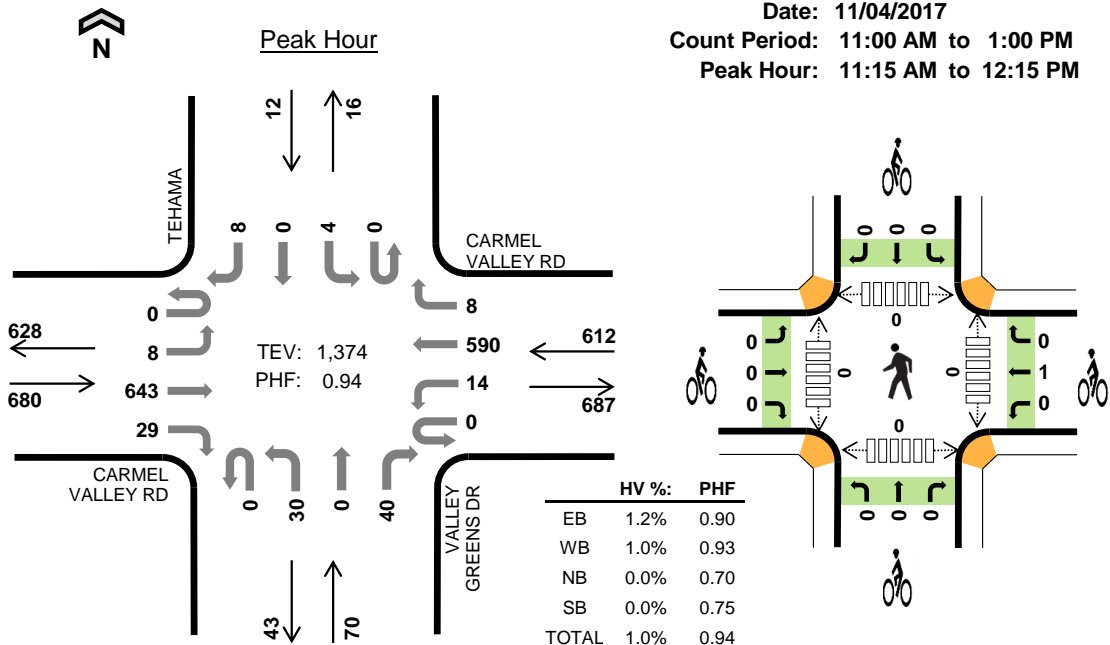

Two-Hour Count Summaries

Interval Start	CARMEL VALLEY RD				CARMEL VALLEY RD				VALLEY GREENS DR				TEHAMA				15-min Total	Rolling One Hour	
	Eastbound		Westbound		Northbound		Southbound		UT	LT	TH	RT	UT	LT	TH	RT			
11:00 AM	0	1	147	5	0	2	150	1	0	1	0	4	0	1	0	2	314	0	
11:15 AM	0	2	144	9	0	5	126	0	0	8	0	6	0	1	0	1	302	0	
11:30 AM	0	2	154	8	0	4	156	5	0	5	0	15	0	0	0	4	353	0	
11:45 AM	0	3	179	6	0	3	157	2	0	8	0	3	0	3	0	0	364	1,333	
12:00 PM	0	1	166	6	0	2	151	1	0	9	0	16	0	0	0	3	355	1,374	
12:15 PM	0	1	135	11	0	4	137	1	0	2	0	5	0	0	0	1	297	1,369	
12:30 PM	0	1	135	9	0	3	131	4	0	3	0	9	0	1	0	1	297	1,313	
12:45 PM	0	2	163	11	0	4	145	0	0	7	0	10	0	0	0	1	343	1,292	
Count Total	0	13	1,223	65	0	27	1,153	14	0	43	0	68	0	6	0	13	2,625	0	
Peak Hour	All	0	8	643	29	0	14	590	8	0	30	0	40	0	4	0	8	1,374	0
	HV	0	0	8	0	0	0	6	0	0	0	0	0	0	0	0	0	14	0
	HV%	-	0%	1%	0%	-	0%	1%	0%	-	0%	-	0%	-	0%	-	0%	1%	0

Note: Two-hour count summary volumes include heavy vehicles but exclude bicycles in overall count.

Interval Start	Heavy Vehicle Totals					Bicycles					Pedestrians (Crossing Leg)				
	EB	WB	NB	SB	Total	EB	WB	NB	SB	Total	East	West	North	South	Total
11:00 AM	1	0	0	0	1	1	1	0	0	2	0	0	0	0	0
11:15 AM	5	1	0	0	6	0	1	0	0	1	0	0	0	0	0
11:30 AM	2	1	0	0	3	0	0	0	0	0	0	0	0	0	0
11:45 AM	1	3	0	0	4	0	0	0	0	0	0	0	0	0	0
12:00 PM	0	1	0	0	1	0	0	0	0	0	0	0	0	0	0
12:15 PM	2	2	1	0	5	1	0	1	0	2	0	0	0	0	0
12:30 PM	1	0	0	0	1	1	0	0	0	1	0	1	1	1	3
12:45 PM	3	1	1	0	5	2	1	0	0	3	0	0	0	0	0
Count Total	15	9	2	0	26	5	3	1	0	9	0	1	1	1	3
Peak Hour	8	6	0	0	14	0	1	0	0	1	0	0	0	0	0



HWY 1 RIBERA RD

Date: 11/02/2017

Count Period: 7:00 AM to 9:00 AM

Peak Hour: 8:00 AM to 9:00 AM

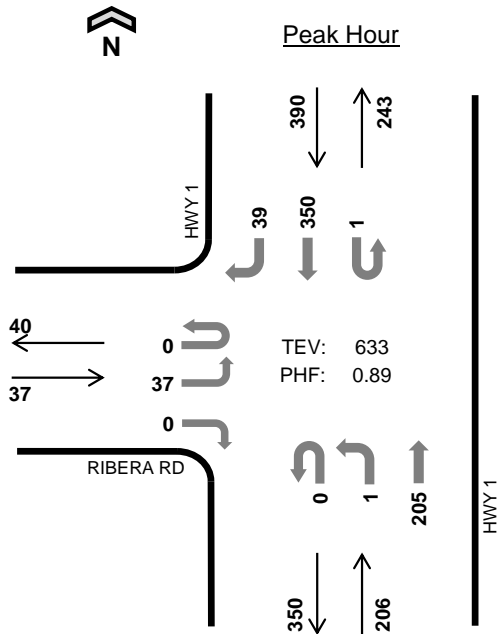

	HV %:	PHF
EB	2.7%	0.62
WB	-	-
NB	2.9%	0.76
SB	4.4%	0.91
TOTAL	3.8%	0.89

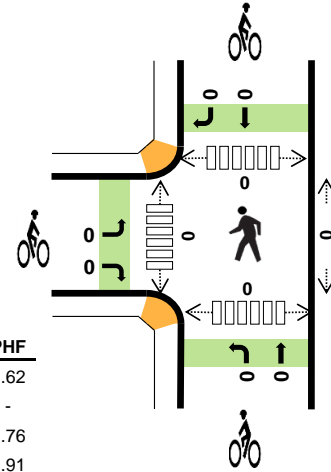

Two-Hour Count Summaries

Interval Start	RIBERA RD				0				HWY 1				HWY 1				15-min Total	Rolling One Hour	
	Eastbound				Westbound				Northbound				Southbound						
	UT	LT	TH	RT	UT	LT	TH	RT	UT	LT	TH	RT	UT	LT	TH	RT			
7:00 AM	0	3	0	1	0	0	0	0	0	0	27	0	0	0	51	3	85	0	
7:15 AM	0	5	0	0	0	0	0	0	0	0	56	0	0	0	66	4	131	0	
7:30 AM	0	8	0	0	0	0	0	0	0	0	35	0	0	0	64	6	113	0	
7:45 AM	0	9	0	0	0	0	0	0	0	0	39	0	0	0	77	17	142	471	
8:00 AM	0	5	0	0	0	0	0	0	0	1	33	0	0	0	101	6	146	532	
8:15 AM	0	15	0	0	0	0	0	0	0	0	61	0	1	0	74	10	161	562	
8:30 AM	0	8	0	0	0	0	0	0	0	0	68	0	0	0	90	11	177	626	
8:45 AM	0	9	0	0	0	0	0	0	0	0	43	0	0	0	85	12	149	633	
Count Total	0	62	0	1	0	0	0	0	0	1	362	0	1	0	608	69	1,104	0	
Peak Hour	All	0	37	0	0	0	0	0	0	0	1	205	0	1	0	350	39	633	0
	HV	0	1	0	0	0	0	0	0	0	0	6	0	0	0	16	1	24	0
	HV%	-	3%	-	-	-	-	-	-	-	0%	3%	-	0%	-	5%	3%	4%	0

Note: Two-hour count summary volumes include heavy vehicles but exclude bicycles in overall count.

Interval Start	Heavy Vehicle Totals					Bicycles					Pedestrians (Crossing Leg)				
	EB	WB	NB	SB	Total	EB	WB	NB	SB	Total	East	West	North	South	Total
7:00 AM	0	0	2	2	4	0	0	0	0	0	0	1	0	0	1
7:15 AM	0	0	4	2	6	0	0	0	0	0	0	0	0	0	0
7:30 AM	0	0	1	2	3	0	0	0	0	0	0	0	0	0	0
7:45 AM	0	0	0	2	2	0	0	0	0	0	0	0	0	0	0
8:00 AM	0	0	1	8	9	0	0	0	0	0	0	0	0	0	0
8:15 AM	0	0	2	2	4	0	0	0	0	0	0	0	0	0	0
8:30 AM	1	0	1	5	7	0	0	0	0	0	0	0	0	0	0
8:45 AM	0	0	2	2	4	0	0	0	0	0	0	0	0	0	0
Count Total	1	0	13	25	39	0	0	0	0	0	0	1	0	0	1
Peak Hr	1	0	6	17	24	0	0	0	0	0	0	0	0	0	0

HWY 1 RIBERA RD



Date: 11/02/2017
 Count Period: 4:00 PM to 6:00 PM
 Peak Hour: 4:00 PM to 5:00 PM

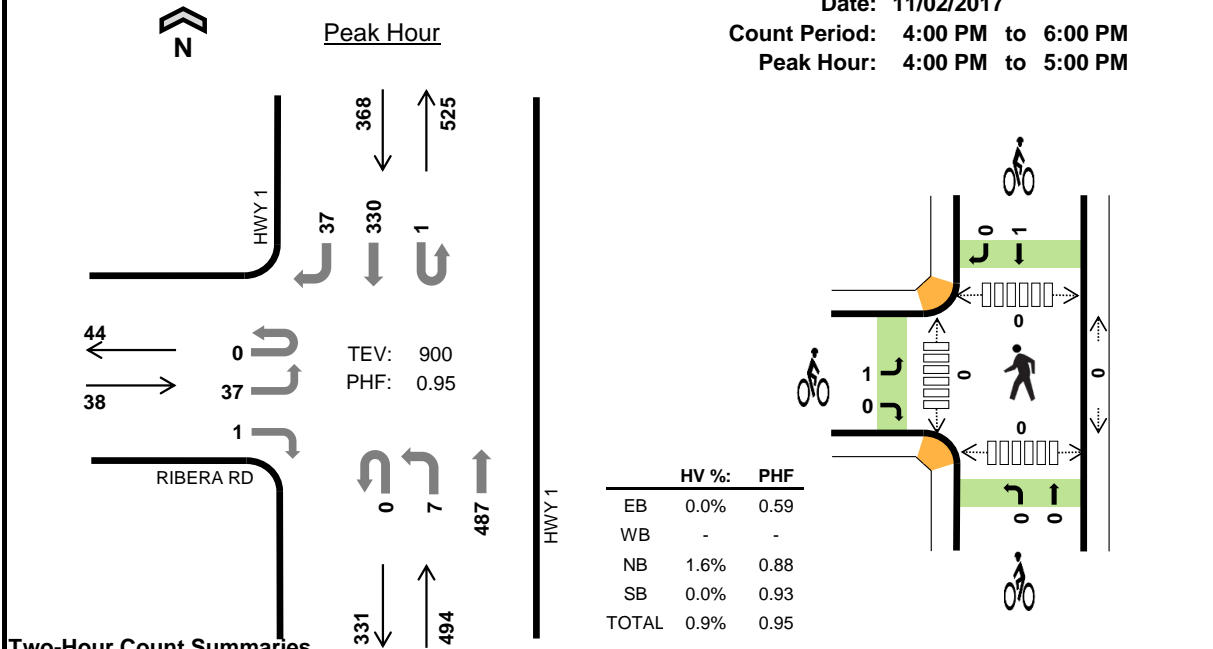

Two-Hour Count Summaries

Interval Start	RIBERA RD				0				HWY 1				HWY 1				15-min Total	Rolling One Hour	
	Eastbound				Westbound				Northbound				Southbound						
	UT	LT	TH	RT	UT	LT	TH	RT	UT	LT	TH	RT	UT	LT	TH	RT			
4:00 PM	0	9	0	0	0	0	0	0	0	0	127	0	1	0	90	8	235	0	
4:15 PM	0	8	0	0	0	0	0	0	0	2	138	0	0	0	82	8	238	0	
4:30 PM	0	16	0	0	0	0	0	0	0	1	123	0	0	0	77	7	224	0	
4:45 PM	0	4	0	1	0	0	0	0	0	4	99	0	0	0	81	14	203	900	
5:00 PM	0	10	0	0	0	0	0	0	0	1	89	0	0	0	72	9	181	846	
5:15 PM	0	11	0	0	0	0	0	0	0	1	89	0	0	0	71	11	183	791	
5:30 PM	0	10	0	1	0	0	0	0	0	0	101	0	0	0	70	9	191	758	
5:45 PM	0	8	0	1	0	0	0	0	0	0	98	0	0	0	67	5	179	734	
Count Total	0	76	0	3	0	0	0	0	0	9	864	0	1	0	610	71	1,634	0	
Peak Hour	All	0	37	0	1	0	0	0	0	0	7	487	0	1	0	330	37	900	0
	HV	0	0	0	0	0	0	0	0	0	8	0	0	0	0	0	0	8	0
	HV%	-	0%	-	0%	-	-	-	-	-	0%	2%	-	0%	-	0%	0%	1%	0

Note: Two-hour count summary volumes include heavy vehicles but exclude bicycles in overall count.

Interval Start	Heavy Vehicle Totals					Bicycles					Pedestrians (Crossing Leg)				
	EB	WB	NB	SB	Total	EB	WB	NB	SB	Total	East	West	North	South	Total
4:00 PM	0	0	1	0	1	0	0	0	0	0	0	0	0	0	0
4:15 PM	0	0	3	0	3	1	0	0	0	1	0	0	0	0	
4:30 PM	0	0	1	0	1	0	0	0	0	0	0	0	0	0	
4:45 PM	0	0	3	0	3	0	0	0	1	1	0	0	0	0	
5:00 PM	0	0	0	2	2	0	0	0	0	0	0	0	0	0	
5:15 PM	0	0	1	0	1	0	0	0	0	0	0	0	0	0	
5:30 PM	0	0	2	1	3	0	0	0	0	0	0	0	0	0	
5:45 PM	0	0	1	1	2	0	0	0	0	0	0	0	0	0	
Count Total	0	0	12	4	16	1	0	0	1	2	0	0	0	0	
Peak Hr	0	0	8	0	8	1	0	0	1	2	0	0	0	0	



HWY 1 RIBERA RD

Date: 11/04/2017

Count Period: 11:00 AM to 1:00 PM

Peak Hour: 11:45 AM to 12:45 PM

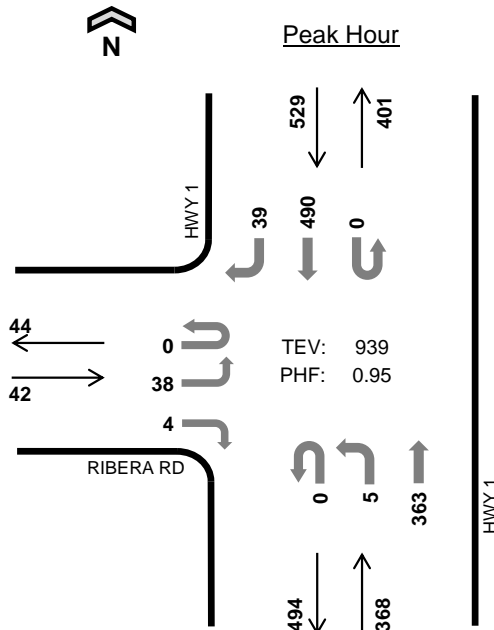

TEV: 939
PHF: 0.95

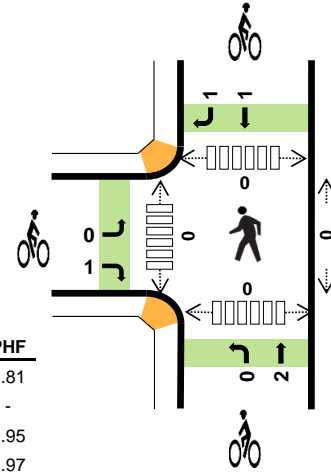

	HV %:	PHF
EB	0.0%	0.81
WB	-	-
NB	0.8%	0.95
SB	0.2%	0.97
TOTAL	0.4%	0.95

Two-Hour Count Summaries

Interval Start	RIBERA RD				0				HWY 1				HWY 1				15-min Total	Rolling One Hour	
	Eastbound				Westbound				Northbound				Southbound						
	UT	LT	TH	RT	UT	LT	TH	RT	UT	LT	TH	RT	UT	LT	TH	RT			
11:00 AM	0	14	0	0	0	0	0	0	0	0	85	0	0	0	126	4	229	0	
11:15 AM	0	5	0	0	0	0	0	0	0	0	76	0	0	0	125	12	218	0	
11:30 AM	0	15	0	0	0	0	0	0	0	2	95	0	0	0	111	9	232	0	
11:45 AM	0	12	0	0	0	0	0	0	0	0	84	0	0	0	119	9	224	903	
12:00 PM	0	11	0	2	0	0	0	0	0	2	95	0	0	0	126	11	247	921	
12:15 PM	0	7	0	0	0	0	0	0	0	2	89	0	0	0	117	10	225	928	
12:30 PM	0	8	0	2	0	0	0	0	0	1	95	0	0	0	128	9	243	939	
12:45 PM	0	8	0	1	0	0	0	0	0	0	77	0	0	0	120	14	220	935	
Count Total	0	80	0	5	0	0	0	0	0	7	696	0	0	0	972	78	1,838	0	
Peak Hour	All	0	38	0	4	0	0	0	0	0	5	363	0	0	0	490	39	939	0
	HV	0	0	0	0	0	0	0	0	0	0	3	0	0	0	1	0	4	0
	HV%	-	0%	-	0%	-	-	-	-	-	0%	1%	-	-	-	0%	0%	0%	0

Note: Two-hour count summary volumes include heavy vehicles but exclude bicycles in overall count.

Interval Start	Heavy Vehicle Totals					Bicycles					Pedestrians (Crossing Leg)				
	EB	WB	NB	SB	Total	EB	WB	NB	SB	Total	East	West	North	South	Total
11:00 AM	0	0	2	1	3	0	0	0	0	0	0	0	0	0	0
11:15 AM	0	0	1	1	2	0	0	1	1	2	0	0	0	0	0
11:30 AM	0	0	0	2	2	0	0	0	0	0	0	0	0	0	0
11:45 AM	0	0	1	0	1	0	0	1	1	2	0	0	0	0	0
12:00 PM	0	0	1	0	1	1	0	1	0	2	0	0	0	0	0
12:15 PM	0	0	0	0	0	0	0	0	1	1	0	0	0	0	0
12:30 PM	0	0	1	1	2	0	0	0	0	0	0	0	0	0	0
12:45 PM	0	0	1	1	2	0	0	0	0	0	0	0	0	0	0
Count Total	0	0	7	6	13	1	0	3	3	7	0	0	0	0	0
Peak Hr	0	0	3	1	4	1	0	2	2	5	0	0	0	0	0

RIO RD ATHERTON DR



Peak Hour

Date: 11/02/2017
Count Period: 7:00 AM to 9:00 AM
Peak Hour: 7:45 AM to 8:45 AM

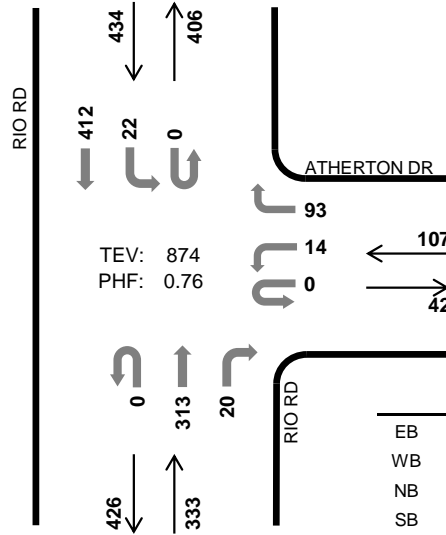

TEV: 874
PHF: 0.76

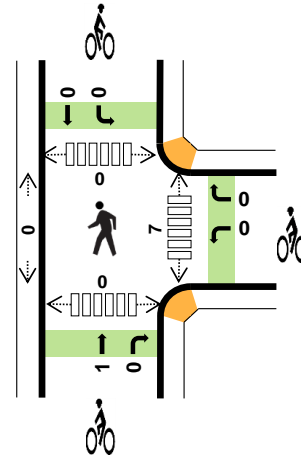

	HV %:	PHF
EB	-	-
WB	0.9%	0.67
NB	4.8%	0.83
SB	3.0%	0.68
TOTAL	3.4%	0.76

Two-Hour Count Summaries

Interval Start	0			ATHERTON DR			RIO RD				RIO RD				15-min Total	Rolling One Hour			
	Eastbound			Westbound			Northbound				Southbound								
	UT	LT	TH	RT	UT	LT	TH	RT	UT	LT	TH	RT	UT	LT	TH	RT			
7:00 AM	0	0	0	0	0	3	0	8	0	0	32	1	0	1	27	0	72	0	
7:15 AM	0	0	0	0	0	9	0	11	0	0	46	6	0	3	34	0	109	0	
7:30 AM	0	0	0	0	0	9	0	15	0	0	56	7	0	2	49	0	138	0	
7:45 AM	0	0	0	0	0	3	0	17	0	0	76	5	0	1	96	0	198	517	
8:00 AM	0	0	0	0	0	3	0	13	0	0	49	6	0	4	83	0	158	603	
8:15 AM	0	0	0	0	0	4	0	36	0	0	96	4	0	4	87	0	231	725	
8:30 AM	0	0	0	0	0	4	0	27	0	0	92	5	0	13	146	0	287	874	
8:45 AM	0	0	0	0	0	5	0	18	0	0	66	1	1	5	88	0	184	860	
Count Total	0	0	0	0	0	40	0	145	0	0	513	35	1	33	610	0	1,377	0	
Peak Hour	All	0	0	0	0	0	14	0	93	0	0	313	20	0	22	412	0	874	0
	HV	0	0	0	0	0	0	0	1	0	0	16	0	0	0	13	0	30	0
	HV%	-	-	-	-	-	0%	-	1%	-	-	5%	0%	-	0%	3%	-	3%	0

Note: Two-hour count summary volumes include heavy vehicles but exclude bicycles in overall count.

Interval Start	Heavy Vehicle Totals					Bicycles					Pedestrians (Crossing Leg)				
	EB	WB	NB	SB	Total	EB	WB	NB	SB	Total	East	West	North	South	Total
7:00 AM	0	0	3	2	5	0	0	0	0	0	3	0	0	0	3
7:15 AM	0	1	2	4	7	0	1	0	2	3	0	0	0	0	0
7:30 AM	0	0	4	3	7	0	0	0	0	0	2	0	0	0	2
7:45 AM	0	0	3	2	5	0	0	0	0	0	1	0	0	0	1
8:00 AM	0	0	3	4	7	0	0	0	0	0	1	0	0	0	1
8:15 AM	0	1	3	4	8	0	0	1	0	1	4	0	0	0	4
8:30 AM	0	0	7	3	10	0	0	0	0	0	1	0	0	0	1
8:45 AM	0	1	2	4	7	0	0	0	0	0	0	0	0	0	0
Count Total	0	3	27	26	56	0	1	1	2	4	12	0	0	0	12
Peak Hr	0	1	16	13	30	0	0	1	0	1	7	0	0	0	7

RIO RD ATHERTON DR



Peak Hour

Date: 11/02/2017
Count Period: 4:00 PM to 6:00 PM
Peak Hour: 4:00 PM to 5:00 PM

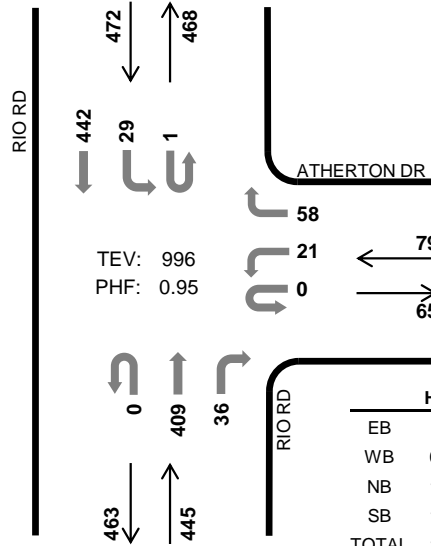

TEV: 996
PHF: 0.95

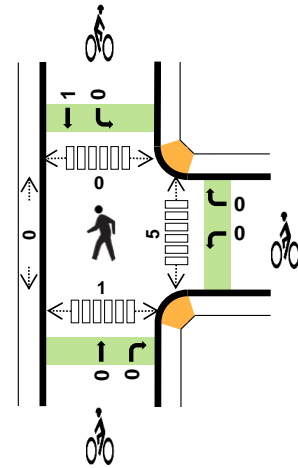

	HV %:	PHF
EB	-	-
WB	0.0%	0.79
NB	1.1%	0.96
SB	1.9%	0.86
TOTAL	1.4%	0.95

Two-Hour Count Summaries

Interval Start	0				ATHERTON DR				RIO RD				RIO RD				15-min Total	Rolling One Hour	
	Eastbound				Westbound				Northbound				Southbound						
	UT	LT	TH	RT	UT	LT	TH	RT	UT	LT	TH	RT	UT	LT	TH	RT			
4:00 PM	0	0	0	0	0	5	0	15	0	0	99	6	0	7	131	0	263	0	
4:15 PM	0	0	0	0	0	4	0	10	0	0	98	10	1	5	105	0	233	0	
4:30 PM	0	0	0	0	0	5	0	15	0	0	104	12	0	9	108	0	253	0	
4:45 PM	0	0	0	0	0	7	0	18	0	0	108	8	0	8	98	0	247	996	
5:00 PM	0	0	0	0	0	1	0	17	0	0	100	10	0	8	112	0	248	981	
5:15 PM	0	0	0	0	0	6	0	23	0	0	106	2	0	12	91	0	240	988	
5:30 PM	0	0	0	0	0	5	0	13	0	0	71	12	0	11	93	0	205	940	
5:45 PM	0	0	0	0	0	6	0	9	0	0	55	11	0	9	79	0	169	862	
Count Total	0	0	0	0	0	39	0	120	0	0	741	71	1	69	817	0	1,858	0	
Peak Hour	All	0	0	0	0	0	21	0	58	0	0	409	36	1	29	442	0	996	0
	HV	0	0	0	0	0	0	0	0	0	0	4	1	0	0	9	0	14	0
	HV%	-	-	-	-	-	0%	-	0%	-	-	1%	3%	0%	0%	2%	-	1%	0

Note: Two-hour count summary volumes include heavy vehicles but exclude bicycles in overall count.

Interval Start	Heavy Vehicle Totals					Bicycles					Pedestrians (Crossing Leg)				
	EB	WB	NB	SB	Total	EB	WB	NB	SB	Total	East	West	North	South	Total
4:00 PM	0	0	1	3	4	0	0	0	0	0	1	0	0	0	1
4:15 PM	0	0	1	1	2	0	0	0	0	0	2	0	0	1	3
4:30 PM	0	0	1	3	4	0	0	0	1	1	1	0	0	0	1
4:45 PM	0	0	2	2	4	0	0	0	0	0	1	0	0	0	1
5:00 PM	0	0	0	1	1	0	0	1	1	2	1	0	0	0	1
5:15 PM	0	0	1	3	4	0	0	0	0	0	0	0	1	0	1
5:30 PM	0	0	1	1	2	0	0	0	1	1	0	0	0	0	0
5:45 PM	0	1	1	0	2	0	0	0	0	0	0	0	0	0	0
Count Total	0	1	8	14	23	0	0	1	3	4	6	0	1	1	8
Peak Hr	0	0	5	9	14	0	0	0	1	1	5	0	0	1	6

RIO RD ATHERTON DR



Peak Hour

Date: 11/04/2017
Count Period: 11:00 AM to 1:00 PM
Peak Hour: 12:00 PM to 1:00 PM

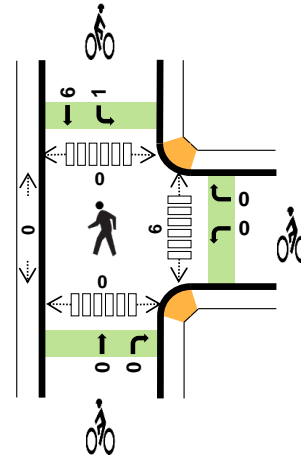
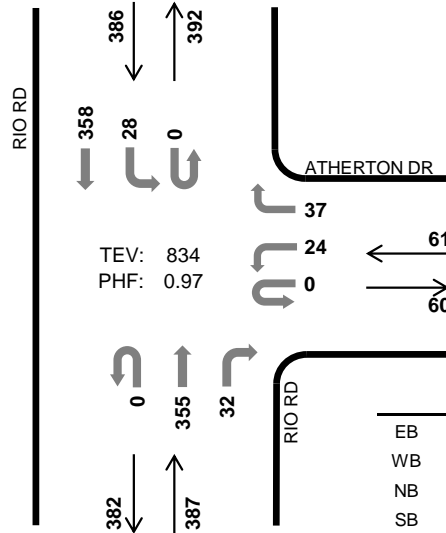

	HV %:	PHF
EB	-	-
WB	0.0%	0.85
NB	1.6%	0.96
SB	1.6%	0.94
TOTAL	1.4%	0.97

Two-Hour Count Summaries

Interval Start	0			ATHERTON DR			RIO RD				RIO RD				15-min Total	Rolling One Hour			
	Eastbound			Westbound			Northbound				Southbound								
	UT	LT	TH	RT	UT	LT	TH	RT	UT	LT	TH	RT	UT	LT	TH	RT			
11:00 AM	0	0	0	0	0	4	0	8	0	0	61	6	0	5	94	0	178	0	
11:15 AM	0	0	0	0	0	8	0	15	0	0	83	6	0	2	100	0	214	0	
11:30 AM	0	0	0	0	0	4	0	11	0	0	74	4	0	9	98	0	200	0	
11:45 AM	0	0	0	0	0	10	0	8	0	0	73	5	1	7	99	0	203	795	
12:00 PM	0	0	0	0	0	9	0	9	0	0	94	6	0	7	86	0	211	828	
12:15 PM	0	0	0	0	0	6	0	11	0	0	92	9	0	5	85	0	208	822	
12:30 PM	0	0	0	0	0	5	0	6	0	0	79	8	0	7	96	0	201	823	
12:45 PM	0	0	0	0	0	4	0	11	0	0	90	9	0	9	91	0	214	834	
Count Total	0	0	0	0	0	50	0	79	0	0	646	53	1	51	749	0	1,629	0	
Peak Hour	All	0	0	0	0	0	24	0	37	0	0	355	32	0	28	358	0	834	0
	HV	0	0	0	0	0	0	0	0	0	0	6	0	0	0	6	0	12	0
	HV%	-	-	-	-	-	0%	-	0%	-	-	2%	0%	-	0%	2%	-	1%	0

Note: Two-hour count summary volumes include heavy vehicles but exclude bicycles in overall count.

Interval Start	Heavy Vehicle Totals					Bicycles					Pedestrians (Crossing Leg)				
	EB	WB	NB	SB	Total	EB	WB	NB	SB	Total	East	West	North	South	Total
11:00 AM	0	0	1	5	6	0	1	0	1	2	2	0	0	0	2
11:15 AM	0	0	0	2	2	0	0	4	1	5	4	0	0	0	4
11:30 AM	0	0	1	1	2	0	1	3	0	4	4	0	0	0	4
11:45 AM	0	0	2	0	2	0	0	0	0	0	1	0	0	0	1
12:00 PM	0	0	3	2	5	0	0	0	1	1	3	0	0	0	3
12:15 PM	0	0	1	0	1	0	0	0	3	3	1	0	0	0	1
12:30 PM	0	0	1	2	3	0	0	0	2	2	2	0	0	0	2
12:45 PM	0	0	1	2	3	0	0	0	1	1	0	0	0	0	0
Count Total	0	0	10	14	24	0	2	7	9	18	17	0	0	0	17
Peak Hr	0	0	6	6	12	0	0	0	7	7	6	0	0	0	6

RIO RD LASUEN DR



Peak Hour

Date: 11/02/2017
Count Period: 7:00 AM to 9:00 AM
Peak Hour: 7:45 AM to 8:45 AM

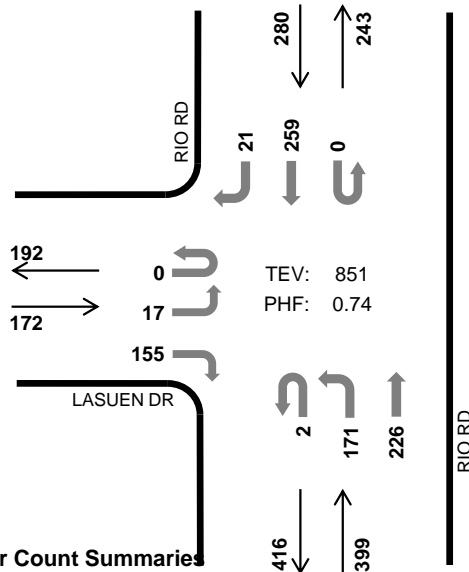

TEV: 851
PHF: 0.74

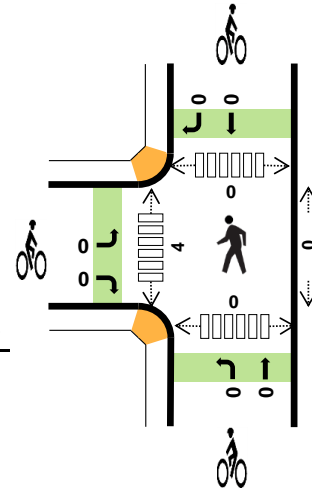

	HV %:	PHF
EB	2.3%	0.57
WB	-	-
NB	4.0%	0.77
SB	2.9%	0.80
TOTAL	3.3%	0.74

Two-Hour Count Summaries

Interval Start	LASUEN DR				0				RIO RD				RIO RD				15-min Total	Rolling One Hour	
	Eastbound				Westbound				Northbound				Southbound						
	UT	LT	TH	RT	UT	LT	TH	RT	UT	LT	TH	RT	UT	LT	TH	RT			
7:00 AM	0	1	0	9	0	0	0	0	0	14	27	0	0	0	20	1	72	0	
7:15 AM	0	0	0	10	0	0	0	0	1	19	37	0	0	0	23	0	90	0	
7:30 AM	0	1	0	12	0	0	0	0	0	14	48	0	1	0	38	1	115	0	
7:45 AM	0	8	0	33	0	0	0	0	0	24	63	0	0	0	67	2	197	474	
8:00 AM	0	6	0	19	0	0	0	0	1	23	33	0	0	0	56	3	141	543	
8:15 AM	0	1	0	30	0	0	0	0	1	65	64	0	0	0	52	13	226	679	
8:30 AM	0	2	0	73	0	0	0	0	0	59	66	0	0	0	84	3	287	851	
8:45 AM	0	2	0	28	0	0	0	0	0	22	49	0	0	0	61	1	163	817	
Count Total	0	21	0	214	0	0	0	0	3	240	387	0	1	0	401	24	1,291	0	
Peak Hour	All	0	17	0	155	0	0	0	0	2	171	226	0	0	0	259	21	851	0
	HV	0	0	0	4	0	0	0	0	0	6	10	0	0	0	8	0	28	0
	HV%	-	0%	-	3%	-	-	-	-	0%	4%	4%	-	-	-	3%	0%	3%	0

Note: Two-hour count summary volumes include heavy vehicles but exclude bicycles in overall count.

Interval Start	Heavy Vehicle Totals					Bicycles					Pedestrians (Crossing Leg)				
	EB	WB	NB	SB	Total	EB	WB	NB	SB	Total	East	West	North	South	Total
7:00 AM	1	0	3	1	5	0	0	0	1	1	0	1	0	0	1
7:15 AM	0	0	4	5	9	0	0	0	0	0	0	1	0	0	1
7:30 AM	2	0	4	2	8	0	0	0	0	0	0	1	0	0	1
7:45 AM	0	0	3	2	5	0	0	0	0	0	0	2	0	0	2
8:00 AM	0	0	2	3	5	0	0	0	0	0	0	1	0	0	1
8:15 AM	2	0	4	2	8	0	0	0	0	0	0	1	0	0	1
8:30 AM	2	0	7	1	10	0	0	0	0	0	0	0	0	0	0
8:45 AM	3	0	2	3	8	0	0	0	0	0	0	0	0	0	0
Count Total	10	0	29	19	58	0	0	0	1	1	0	7	0	0	7
Peak Hr	4	0	16	8	28	0	0	0	0	0	0	4	0	0	4

RIO RD LASUEN DR



Peak Hour

Date: 11/02/2017
Count Period: 4:00 PM to 6:00 PM
Peak Hour: 4:00 PM to 5:00 PM

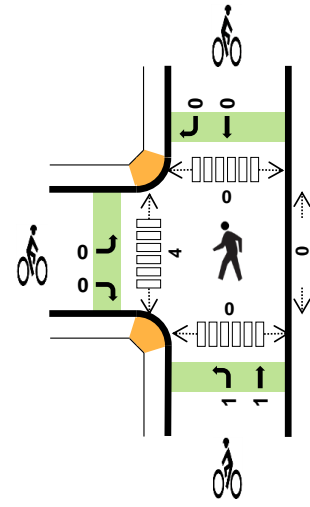
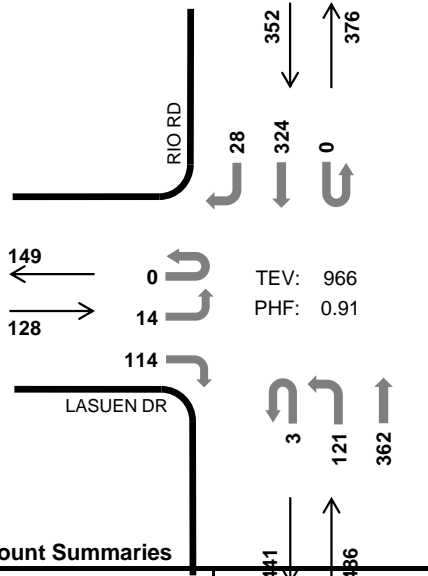

	HV %:	PHF
EB	0.8%	0.68
WB	-	-
NB	0.8%	0.91
SB	2.6%	0.93
TOTAL	1.4%	0.91

Two-Hour Count Summaries

Interval Start	LASUEN DR						RIO RD				RIO RD				15-min Total	Rolling One Hour			
	Eastbound			Westbound			Northbound				Southbound								
	UT	LT	TH	RT	UT	LT	TH	RT	UT	LT	TH	RT	UT	LT	TH	RT			
4:00 PM	0	5	0	42	0	0	0	0	0	21	103	0	0	0	88	7	266	0	
4:15 PM	0	4	0	34	0	0	0	0	1	22	85	0	0	0	72	8	226	0	
4:30 PM	0	3	0	22	0	0	0	0	2	31	87	0	0	0	83	6	234	0	
4:45 PM	0	2	0	16	0	0	0	0	0	47	87	0	0	0	81	7	240	966	
5:00 PM	0	2	0	30	0	0	0	0	1	38	88	0	0	0	79	6	244	944	
5:15 PM	0	3	0	16	0	0	0	0	0	47	84	0	0	0	73	9	232	950	
5:30 PM	0	3	0	31	0	0	0	0	0	18	67	0	0	0	67	7	193	909	
5:45 PM	0	1	0	28	0	0	0	0	0	11	47	0	0	0	53	2	142	811	
Count Total	0	23	0	219	0	0	0	0	4	235	648	0	0	0	596	52	1,777	0	
Peak Hour	All	0	14	0	114	0	0	0	0	3	121	362	0	0	0	324	28	966	0
	HV	0	0	0	1	0	0	0	0	0	0	4	0	0	0	9	0	14	0
	HV%	-	0%	-	1%	-	-	-	-	0%	0%	1%	-	-	-	3%	0%	1%	0

Note: Two-hour count summary volumes include heavy vehicles but exclude bicycles in overall count.

Interval Start	Heavy Vehicle Totals					Bicycles					Pedestrians (Crossing Leg)				
	EB	WB	NB	SB	Total	EB	WB	NB	SB	Total	East	West	North	South	Total
4:00 PM	1	0	1	2	4	0	0	0	0	0	0	0	0	0	0
4:15 PM	0	0	1	3	4	0	0	2	0	2	0	1	0	0	1
4:30 PM	0	0	1	2	3	0	0	0	0	0	0	3	0	0	3
4:45 PM	0	0	1	2	3	0	0	0	0	0	0	0	0	0	0
5:00 PM	0	0	0	1	1	1	0	0	0	1	0	3	0	0	3
5:15 PM	0	0	1	3	4	0	0	0	0	0	0	5	0	0	5
5:30 PM	0	0	2	2	4	0	0	0	0	0	0	0	0	0	0
5:45 PM	0	0	0	0	0	0	0	0	0	0	0	0	0	0	0
Count Total	1	0	7	15	23	1	0	2	0	3	0	12	0	0	12
Peak Hr	1	0	4	9	14	0	0	2	0	2	0	4	0	0	4

RIO RD LASUEN DR



Date: 11/04/2017
 Count Period: 11:00 AM to 1:00 PM
 Peak Hour: 11:15 AM to 12:15 PM

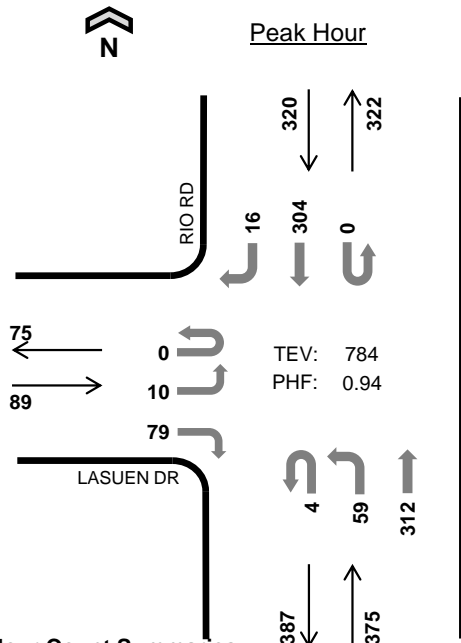

	HV %:	PHF
EB	2.2%	0.72
WB	-	-
NB	1.6%	0.92
SB	1.3%	0.87
TOTAL	1.5%	0.94

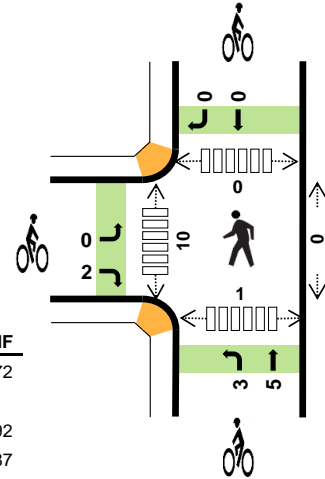

Two-Hour Count Summaries

Interval Start	LASUEN DR				0				RIO RD				RIO RD				15-min Total	Rolling One Hour	
	Eastbound				Westbound				Northbound				Southbound						
	UT	LT	TH	RT	UT	LT	TH	RT	UT	LT	TH	RT	UT	LT	TH	RT			
11:00 AM	0	3	0	23	0	0	0	0	1	11	56	0	0	0	71	3	168	0	
11:15 AM	0	4	0	21	0	0	0	0	1	16	81	0	0	0	79	7	209	0	
11:30 AM	0	4	0	27	0	0	0	0	1	17	75	0	0	0	69	3	196	0	
11:45 AM	0	1	0	13	0	0	0	0	1	13	68	0	0	0	88	4	188	761	
12:00 PM	0	1	0	18	0	0	0	0	1	13	88	0	0	0	68	2	191	784	
12:15 PM	0	1	0	20	0	0	0	0	0	20	86	0	0	0	69	1	197	772	
12:30 PM	0	0	0	25	0	0	0	0	1	12	71	0	0	0	66	1	176	752	
12:45 PM	0	2	0	20	0	0	0	0	0	17	92	0	0	0	77	6	214	778	
Count Total	0	16	0	167	0	0	0	0	6	119	617	0	0	0	587	27	1,539	0	
Peak Hour	All	0	10	0	79	0	0	0	0	4	59	312	0	0	0	304	16	784	0
	HV	0	0	0	2	0	0	0	0	0	1	5	0	0	0	3	1	12	0
	HV%	-	0%	-	3%	-	-	-	-	0%	2%	2%	-	-	-	1%	6%	2%	0

Note: Two-hour count summary volumes include heavy vehicles but exclude bicycles in overall count.

Interval Start	Heavy Vehicle Totals					Bicycles					Pedestrians (Crossing Leg)				
	EB	WB	NB	SB	Total	EB	WB	NB	SB	Total	East	West	North	South	Total
11:00 AM	2	0	1	3	6	0	0	0	1	1	0	2	0	0	2
11:15 AM	1	0	0	2	3	1	0	4	0	5	0	4	0	0	4
11:30 AM	0	0	1	1	2	0	0	3	0	3	0	2	0	0	2
11:45 AM	0	0	2	0	2	0	0	1	0	1	0	2	0	0	2
12:00 PM	1	0	3	1	5	1	0	0	0	1	0	2	0	1	3
12:15 PM	0	0	0	0	0	3	0	0	0	3	0	2	0	2	4
12:30 PM	1	0	2	1	4	2	0	1	0	3	0	4	0	0	4
12:45 PM	0	0	1	2	3	0	0	0	0	0	0	1	0	1	
Count Total	5	0	10	10	25	7	0	9	1	17	0	19	0	3	22
Peak Hr	2	0	6	4	12	2	0	8	0	10	0	10	0	1	11

RIO RD SANTA LUCIA AVE



Peak Hour

Date: 11/02/2017
Count Period: 7:00 AM to 9:00 AM
Peak Hour: 7:45 AM to 8:45 AM

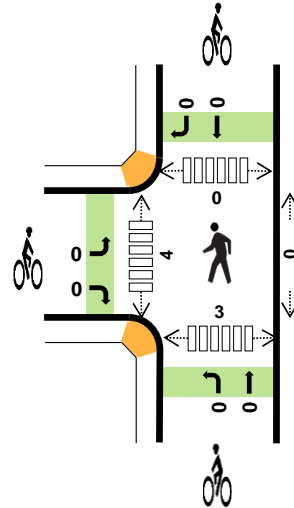
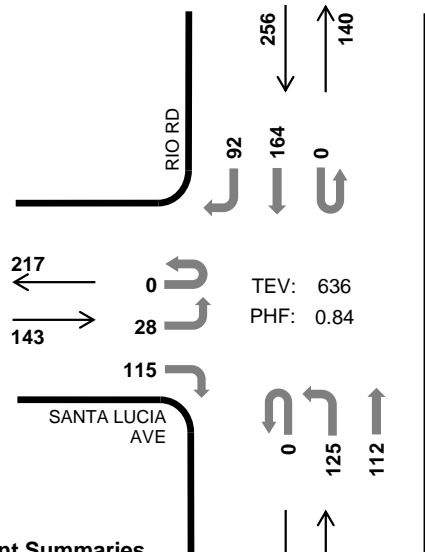

	HV %:	PHF
EB	2.1%	0.52
WB	-	-
NB	4.2%	0.86
SB	2.7%	0.78
TOTAL	3.1%	0.84

Two-Hour Count Summaries

Interval Start	SANTA LUCIA AVE						RIO RD			RIO RD			15-min Total	Rolling One Hour		
	Eastbound			Westbound			Northbound			Southbound						
	UT	LT	TH	RT	UT	LT	TH	RT	UT	LT	TH	RT				
7:00 AM	0	1	0	4	0	0	0	0	0	14	11	0	0	0	47	0
7:15 AM	0	1	0	11	0	0	0	0	0	15	21	0	0	0	73	0
7:30 AM	0	3	0	10	0	0	0	0	0	23	33	0	0	0	111	0
7:45 AM	0	4	0	14	0	0	0	0	0	26	41	0	0	0	167	398
8:00 AM	0	3	0	24	0	0	0	0	0	20	17	0	0	0	117	468
8:15 AM	0	4	0	25	0	0	0	0	0	44	20	0	0	0	163	558
8:30 AM	0	17	0	52	0	0	0	0	0	35	34	0	0	0	189	636
8:45 AM	0	3	0	24	0	0	0	0	0	24	32	0	0	0	133	602
Count Total	0	36	0	164	0	0	0	0	0	201	209	0	0	0	1,000	0
Peak Hour	All	0	28	0	115	0	0	0	0	125	112	0	0	0	636	0
	HV	0	1	0	2	0	0	0	0	3	7	0	0	0	20	0
	HV%	-	4%	-	2%	-	-	-	-	-	2%	6%	-	-	3%	0

Note: Two-hour count summary volumes include heavy vehicles but exclude bicycles in overall count.

Interval Start	Heavy Vehicle Totals					Bicycles					Pedestrians (Crossing Leg)				
	EB	WB	NB	SB	Total	EB	WB	NB	SB	Total	East	West	North	South	Total
7:00 AM	0	0	2	0	2	0	0	0	1	1	0	1	0	0	1
7:15 AM	2	0	2	3	7	0	0	0	0	0	0	1	0	0	1
7:30 AM	1	0	5	1	7	0	0	0	0	0	0	1	0	0	1
7:45 AM	2	0	2	2	6	0	0	0	0	0	0	2	0	0	2
8:00 AM	0	0	2	2	4	0	0	0	0	0	0	1	0	1	2
8:15 AM	1	0	2	2	5	0	0	0	0	0	0	1	0	2	3
8:30 AM	0	0	4	1	5	0	0	0	0	0	0	0	0	0	0
8:45 AM	1	0	3	2	6	0	0	0	0	0	0	0	0	0	0
Count Total	7	0	22	13	42	0	0	0	1	1	0	7	0	3	10
Peak Hr	3	0	10	7	20	0	0	0	0	0	0	4	0	3	7

RIO RD SANTA LUCIA AVE



Peak Hour
N

Date: 11/02/2017
Count Period: 4:00 PM to 6:00 PM
Peak Hour: 4:00 PM to 5:00 PM

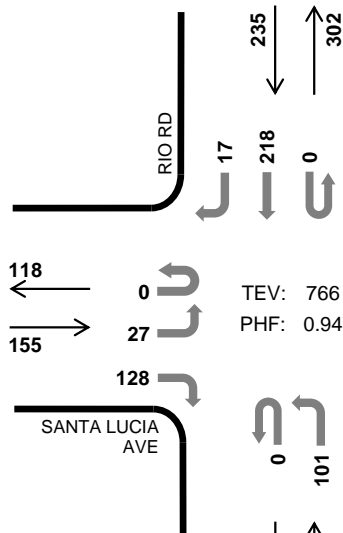

TEV: 766
PHF: 0.94

	HV %:	PHF
EB	1.9%	0.90
WB	-	-
NB	1.1%	0.89
SB	2.6%	0.90
TOTAL	1.7%	0.94

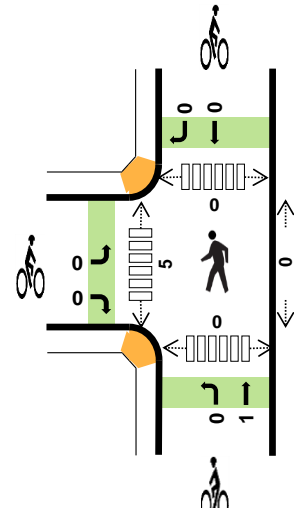

Two-Hour Count Summaries

Interval Start	SANTA LUCIA AVE				RIO RD				RIO RD				15-min Total	Rolling One Hour					
	Eastbound				Westbound				Northbound						Southbound				
	UT	LT	TH	RT	UT	LT	TH	RT	UT	LT	TH	RT	UT	LT	TH	RT			
4:00 PM	0	8	0	35	0	0	0	0	0	28	78	0	0	0	53	2	204	0	
4:15 PM	0	6	0	28	0	0	0	0	0	30	63	0	0	0	51	2	180	0	
4:30 PM	0	6	0	36	0	0	0	0	0	22	66	0	0	0	58	7	195	0	
4:45 PM	0	7	0	29	0	0	0	0	0	21	68	0	0	0	56	6	187	766	
5:00 PM	0	4	0	29	0	0	0	0	0	29	57	0	0	0	63	4	186	748	
5:15 PM	0	8	0	30	0	0	0	0	0	23	66	0	0	0	49	2	178	746	
5:30 PM	0	7	0	22	0	0	0	0	0	18	53	0	0	0	51	1	152	703	
5:45 PM	0	3	0	21	0	0	0	0	0	13	34	0	0	0	36	5	112	628	
Count Total	0	49	0	230	0	0	0	0	0	184	485	0	0	0	417	29	1,394	0	
Peak Hour	All	0	27	0	128	0	0	0	0	0	101	275	0	0	0	218	17	766	0
	HV	0	0	0	3	0	0	0	0	0	1	3	0	0	0	6	0	13	0
	HV%	-	0%	-	2%	-	-	-	-	-	1%	1%	-	-	-	3%	0%	2%	0

Note: Two-hour count summary volumes include heavy vehicles but exclude bicycles in overall count.

Interval Start	Heavy Vehicle Totals					Bicycles					Pedestrians (Crossing Leg)				
	EB	WB	NB	SB	Total	EB	WB	NB	SB	Total	East	West	North	South	Total
4:00 PM	1	0	1	1	3	0	0	0	0	0	0	0	0	0	0
4:15 PM	2	0	1	1	4	0	0	1	0	1	0	1	0	0	1
4:30 PM	0	0	1	2	3	0	0	0	0	0	0	4	0	0	4
4:45 PM	0	0	1	2	3	0	0	0	0	0	0	0	0	0	0
5:00 PM	1	0	0	1	2	0	0	0	0	0	0	0	0	0	0
5:15 PM	0	0	1	2	3	0	0	0	0	0	0	1	0	1	2
5:30 PM	2	0	2	0	4	0	0	0	0	0	0	0	0	0	0
5:45 PM	0	0	0	0	0	0	0	0	0	0	0	0	0	0	0
Count Total	6	0	7	9	22	0	0	1	0	1	0	6	0	1	7
Peak Hr	3	0	4	6	13	0	0	1	0	1	0	5	0	0	5

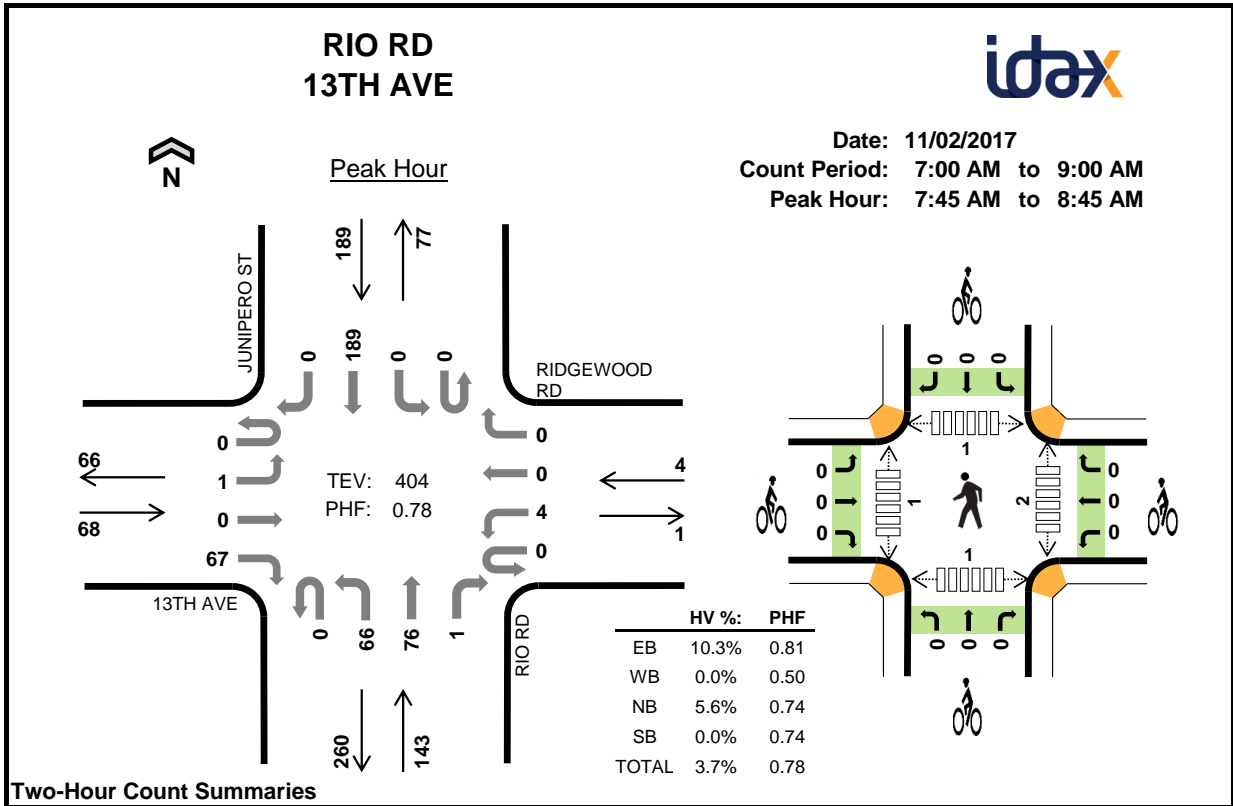

Two-Hour Count Summaries

Interval Start	13TH AVE				RIDGEWOOD RD				RIO RD				JUNIPERO ST				15-min Total	Rolling One Hour	
	Eastbound		Westbound		Westbound		Northbound		Northbound		Southbound		Southbound						
	UT	LT	TH	RT	UT	LT	TH	RT	UT	LT	TH	RT	UT	LT	TH	RT			
7:00 AM	0	0	0	6	0	0	0	0	0	8	3	0	0	0	13	0	30	0	
7:15 AM	0	0	0	10	0	2	0	0	0	15	7	1	0	0	9	0	44	0	
7:30 AM	0	0	0	10	0	1	0	0	0	19	11	0	0	0	31	0	72	0	
7:45 AM	0	0	0	17	0	1	0	0	0	25	22	0	0	0	64	0	129	275	
8:00 AM	0	0	0	17	0	0	0	0	0	9	14	0	0	0	33	0	73	318	
8:15 AM	0	0	0	21	0	1	0	0	0	11	13	1	0	0	54	0	101	375	
8:30 AM	0	1	0	12	0	2	0	0	0	21	27	0	0	0	38	0	101	404	
8:45 AM	0	1	0	22	0	1	0	0	0	20	15	1	0	0	19	0	79	354	
Count Total	0	2	0	115	0	8	0	0	0	128	112	3	0	0	261	0	629	0	
Peak Hour	All	0	1	0	67	0	4	0	0	0	66	76	1	0	0	189	0	404	0
	HV	0	0	0	7	0	0	0	0	0	8	0	0	0	0	0	0	15	0
	HV%	-	0%	-	10%	-	0%	-	-	-	12%	0%	0%	-	-	0%	-	4%	0

Note: Two-hour count summary volumes include heavy vehicles but exclude bicycles in overall count.

Interval Start	Heavy Vehicle Totals					Bicycles					Pedestrians (Crossing Leg)				
	EB	WB	NB	SB	Total	EB	WB	NB	SB	Total	East	West	North	South	Total
7:00 AM	0	0	0	0	0	1	0	0	0	1	1	0	0	0	1
7:15 AM	3	0	0	0	3	0	0	0	0	0	0	1	0	0	1
7:30 AM	1	0	5	0	6	0	0	0	0	0	1	0	0	0	1
7:45 AM	1	0	3	0	4	0	0	0	0	0	1	1	1	1	4
8:00 AM	3	0	1	0	4	0	0	0	0	0	0	0	0	0	0
8:15 AM	2	0	0	0	2	0	0	0	0	0	1	0	0	0	1
8:30 AM	1	0	4	0	5	0	0	0	0	0	0	0	0	0	0
8:45 AM	1	0	2	1	4	0	0	0	0	0	0	0	0	0	0
Count Total	12	0	15	1	28	1	0	0	0	1	4	2	1	1	8
Peak Hour	7	0	8	0	15	0	0	0	0	0	2	1	1	1	5

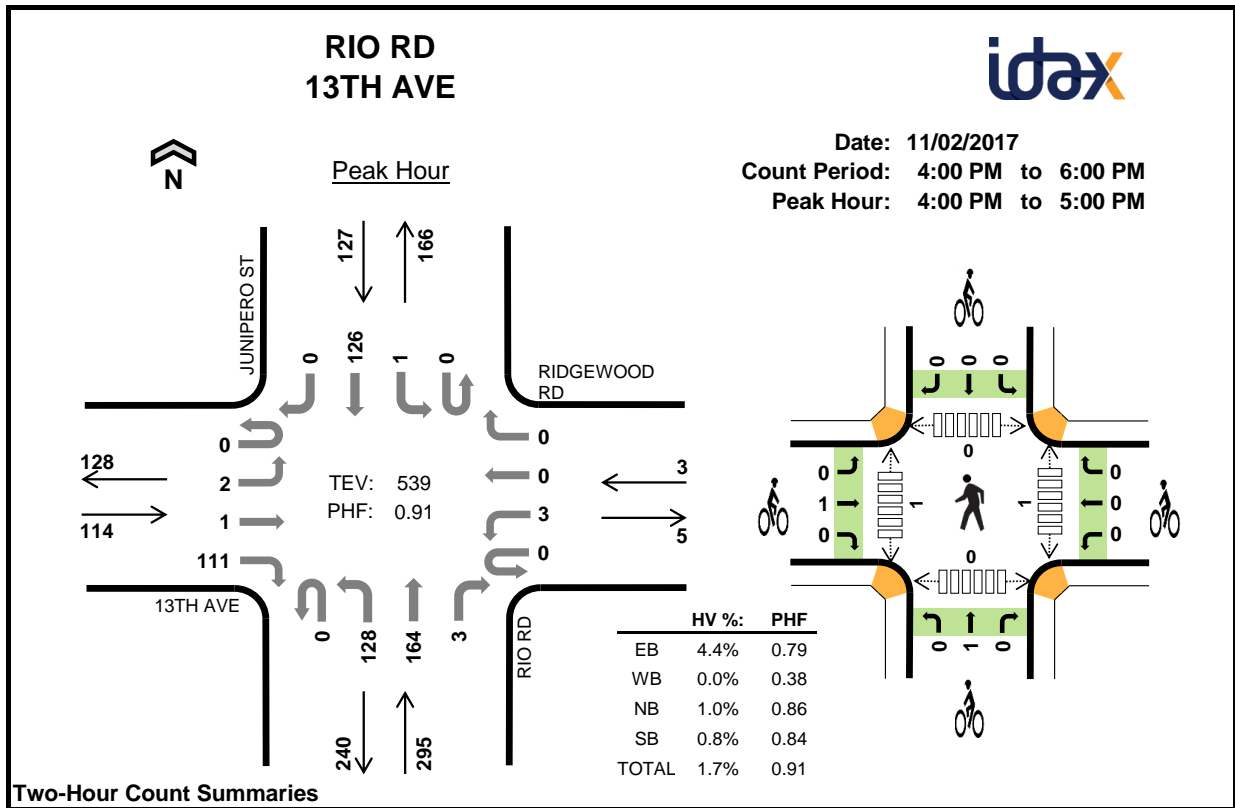

Two-Hour Count Summaries

Interval Start	13TH AVE				RIDGEWOOD RD				RIO RD				JUNIPERO ST				15-min Total	Rolling One Hour	
	Eastbound		Westbound		Westbound		Northbound		Northbound		Southbound		Southbound						
	UT	LT	TH	RT	UT	LT	TH	RT	UT	LT	TH	RT	UT	LT	TH	RT			
4:00 PM	0	1	1	22	0	0	0	0	0	37	49	0	0	1	37	0	148	0	
4:15 PM	0	0	0	24	0	2	0	0	0	31	33	0	0	0	27	0	117	0	
4:30 PM	0	1	0	29	0	0	0	0	0	32	37	3	0	0	35	0	137	0	
4:45 PM	0	0	0	36	0	1	0	0	0	28	45	0	0	0	27	0	137	539	
5:00 PM	0	0	0	26	0	0	0	0	0	29	38	1	0	0	36	0	130	521	
5:15 PM	0	1	0	20	0	1	0	0	0	41	31	1	0	0	34	0	129	533	
5:30 PM	0	0	0	22	0	0	0	0	0	32	27	0	0	0	26	0	107	503	
5:45 PM	0	0	0	18	0	0	0	0	0	27	13	0	0	0	23	0	81	447	
Count Total	0	3	1	197	0	4	0	0	0	257	273	5	0	1	245	0	986	0	
Peak Hour	All	0	2	1	111	0	3	0	0	0	128	164	3	0	1	126	0	539	0
	HV	0	0	0	5	0	0	0	0	0	1	2	0	0	0	1	0	9	0
	HV%	-	0%	0%	5%	-	0%	-	-	-	1%	1%	0%	-	0%	1%	-	2%	0

Note: Two-hour count summary volumes include heavy vehicles but exclude bicycles in overall count.

Interval Start	Heavy Vehicle Totals					Bicycles					Pedestrians (Crossing Leg)				
	EB	WB	NB	SB	Total	EB	WB	NB	SB	Total	East	West	North	South	Total
4:00 PM	0	0	0	1	1	0	0	0	0	0	0	0	0	0	0
4:15 PM	1	0	1	0	2	0	0	1	0	1	0	0	0	0	0
4:30 PM	2	0	1	0	3	1	0	0	0	1	1	1	0	0	2
4:45 PM	2	0	1	0	3	0	0	0	0	0	0	0	0	0	0
5:00 PM	0	0	0	0	0	0	0	0	0	0	0	0	0	0	0
5:15 PM	3	0	1	0	4	0	0	0	0	0	0	0	0	0	0
5:30 PM	0	0	0	0	0	0	0	0	0	0	0	0	0	0	0
5:45 PM	0	0	0	0	0	0	0	0	0	0	0	0	0	0	0
Count Total	8	0	4	1	13	1	0	1	0	2	1	1	0	0	2
Peak Hour	5	0	3	1	9	1	0	1	0	2	1	1	0	0	2



RIO RD 13TH AVE



Peak Hour

Date: 11/04/2017
Count Period: 11:00 AM to 1:00 PM
Peak Hour: 12:00 PM to 1:00 PM

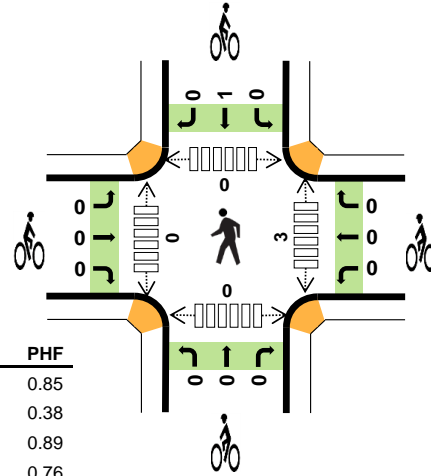
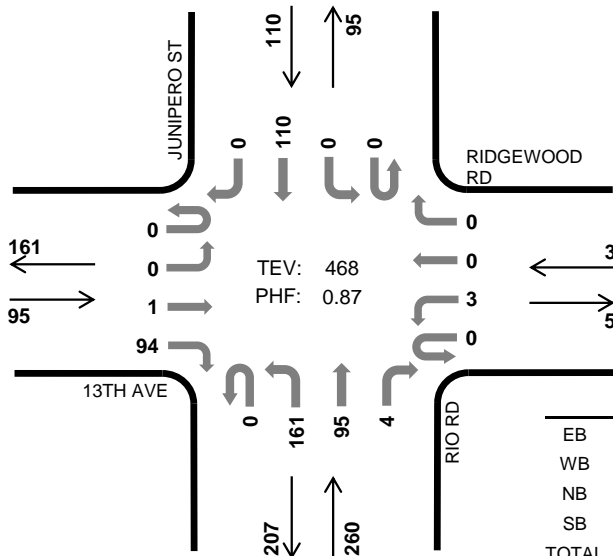

	HV %:	PHF
EB	4.2%	0.85
WB	0.0%	0.38
NB	1.2%	0.89
SB	0.9%	0.76
TOTAL	1.7%	0.87

Two-Hour Count Summaries

Interval Start	13TH AVE				RIDGEWOOD RD				RIO RD				JUNIPERO ST				15-min Total	Rolling One Hour	
	Eastbound		Westbound		Westbound		Northbound		Northbound		Southbound		Southbound						
	UT	LT	TH	RT	UT	LT	TH	RT	UT	LT	TH	RT	UT	LT	TH	RT			
11:00 AM	0	2	0	22	0	0	0	0	0	24	17	0	0	0	25	0	90	0	
11:15 AM	0	1	0	22	0	1	0	0	0	33	38	0	0	0	25	1	121	0	
11:30 AM	0	0	2	22	0	0	0	0	0	33	22	0	0	0	22	0	101	0	
11:45 AM	0	2	0	34	0	1	0	0	0	17	29	1	0	0	25	0	109	421	
12:00 PM	0	0	1	27	0	1	0	0	0	40	27	1	0	0	22	0	119	450	
12:15 PM	0	0	0	19	0	0	0	0	0	38	21	1	0	0	36	0	115	444	
12:30 PM	0	0	0	23	0	2	0	0	0	36	22	1	0	0	16	0	100	443	
12:45 PM	0	0	0	25	0	0	0	0	0	47	25	1	0	0	36	0	134	468	
Count Total	0	5	3	194	0	5	0	0	0	268	201	5	0	0	207	1	889	0	
Peak Hour	All	0	0	1	94	0	3	0	0	0	161	95	4	0	0	110	0	468	0
	HV	0	0	0	4	0	0	0	0	0	3	0	0	0	0	1	0	8	0
	HV%	-	-	0%	4%	-	0%	-	-	-	2%	0%	0%	-	-	1%	-	2%	0

Note: Two-hour count summary volumes include heavy vehicles but exclude bicycles in overall count.

Interval Start	Heavy Vehicle Totals					Bicycles					Pedestrians (Crossing Leg)				
	EB	WB	NB	SB	Total	EB	WB	NB	SB	Total	East	West	North	South	Total
11:00 AM	2	0	1	0	3	1	1	0	0	2	0	0	0	0	0
11:15 AM	2	0	0	0	2	0	1	3	0	4	2	0	0	0	2
11:30 AM	1	0	1	0	2	0	0	2	0	2	0	0	0	0	0
11:45 AM	0	0	1	0	1	0	0	0	0	0	0	0	0	0	0
12:00 PM	1	0	1	0	2	0	0	0	1	1	2	0	0	0	2
12:15 PM	0	0	0	0	0	0	0	0	0	0	1	0	0	0	1
12:30 PM	1	0	2	0	3	0	0	0	0	0	0	0	0	0	0
12:45 PM	2	0	0	1	3	0	0	0	0	0	0	0	0	0	0
Count Total	9	0	6	1	16	1	2	5	1	9	5	0	0	0	5
Peak Hour	4	0	3	1	8	0	0	0	1	1	3	0	0	0	3



Monterey County Resource Management Agency - Public Works

Carmel Valley Road Data Sheet

Carmel Valley Road
 Segment 6 - Robinson Canyon Road to Schulte Road
 Count Location No. 235 - West of Loma Del Rey Road
 Dates: 10/18/2016 to 10/24/2016
 Sheet 1

Tuesday, October 18, 2016						
Hour	NORTH/EAST		SOUTH/WEST		Combined	
	AM	PM	AM	PM	AM	PM
0:00	2	115	4	116	6	231
0:15	7	128	2	121	9	249
0:30	2	113	2	137	4	250
0:45	2	124	4	149	6	273
1:00	3	123	0	116	3	239
1:15	2	121	0	133	2	254
1:30	3	127	1	107	4	234
1:45	3	121	0	117	3	238
2:00	0	143	1	120	1	263
2:15	2	143	1	125	3	268
2:30	2	161	1	128	3	289
2:45	0	142	1	127	1	269
3:00	5	150	0	129	5	279
3:15	1	183	1	146	2	329
3:30	2	181	2	119	4	300
3:45	2	187	2	124	4	311
4:00	1	198	0	138	1	336
4:15	1	200	4	115	5	315
4:30	2	205	5	126	7	331
4:45	6	205	7	129	13	334
5:00	3	195	9	129	12	324
5:15	9	225	18	97	27	322
5:30	19	192	18	85	37	277
5:45	22	179	28	103	50	282
6:00	22	182	31	94	53	276
6:15	30	154	43	98	73	252
6:30	20	141	78	57	98	198
6:45	31	123	76	56	107	179
7:00	51	78	157	67	208	145
7:15	78	89	250	49	328	138
7:30	102	59	197	38	299	97
7:45	125	72	178	26	303	98
8:00	112	58	162	33	274	91
8:15	108	48	168	22	276	70
8:30	120	40	207	18	327	58
8:45	104	47	242	19	351	66
9:00	103	53	151	16	254	69
9:15	87	42	150	15	237	57
9:30	97	39	146	10	243	49
9:45	87	35	124	15	211	50
10:00	76	27	153	14	229	41
10:15	75	16	129	23	204	39
10:30	102	11	126	11	228	22
10:45	124	17	118	10	242	27
11:00	110	11	121	11	231	22
11:15	95	10	126	2	221	12
11:30	119	11	134	6	253	17
11:45	112	10	148	5	260	15
Total	2191	5234	3526	3651	5717	8885
Day Total	7425	7177	14602			

Wednesday, October 19, 2016						
Hour	NORTH/EAST		SOUTH/WEST		Combined	
	AM	PM	AM	PM	AM	PM
0:00	3	117	3	134	6	251
0:15	2	136	1	110	3	246
0:30	4	146	3	134	7	280
0:45	5	106	6	125	11	231
1:00	1	131	0	114	1	245
1:15	0	131	0	121	0	252
1:30	0	129	1	118	1	247
1:45	1	135	1	93	2	228
2:00	0	127	0	128	0	255
2:15	1	152	1	112	2	264
2:30	0	135	0	137	0	272
2:45	3	166	1	134	4	300
3:00	2	185	1	116	3	301
3:15	0	186	0	158	0	344
3:30	1	163	0	126	1	289
3:45	0	187	3	135	3	322
4:00	6	222	2	109	8	331
4:15	4	203	5	116	9	319
4:30	1	213	5	102	6	315
4:45	4	256	9	106	13	362
5:00	4	211	9	127	13	338
5:15	6	204	8	104	14	308
5:30	15	237	20	101	35	338
5:45	25	173	27	100	52	273
6:00	23	166	32	90	55	256
6:15	23	153	45	77	68	230
6:30	31	138	63	69	94	207
6:45	29	119	89	73	118	192
7:00	57	106	129	51	186	157
7:15	69	78	263	42	311	120
7:30	85	75	210	36	295	111
7:45	131	72	194	41	325	113
8:00	108	84	157	25	265	109
8:15	124	81	159	45	283	126
8:30	99	72	195	31	294	103
8:45	113	67	228	55	341	122
9:00	100	32	167	21	267	53
9:15	104	54	133	45	237	99
9:30	100	39	153	27	253	66
9:45	72	15	169	19	241	34
10:00	62	29	140	34	202	63
10:15	95	11	155	19	250	30
10:30	91	18	124	25	215	43
10:45	97	14	146	8	243	22
11:00	122	12	148	12	270	24
11:15	109	12	122	7	231	19
11:30	108	10	149	3	257	13
11:45	110	16	139	4	249	20
Total	2150	5524	3615	3719	5765	9243
Day Total	7674	7334	15008			

Thursday, October 20, 2016						
Hour	NORTH/EAST		SOUTH/WEST		Combined	
	AM	PM	AM	PM	AM	PM
0:00	7	137	3	123	10	260
0:15	6	123	6	133	12	256
0:30	0	138	2	143	2	281
0:45	2	121	3	143	5	264
1:00	2	108	3	124	5	232
1:15	2	134	3	123	5	257
1:30	1	125	2	150	3	275
1:45	3	129	2	110	5	239
2:00	1	120	3	168	4	288
2:15	0	146	1	138	1	284
2:30	1	171	2	116	3	287
2:45	0	175	2	127	2	302
3:00	2	152	0	123	2	275
3:15	1	181	1	141	2	322
3:30	2	158	0	152	2	310
3:45	2	210	1	111	3	321
4:00	4	205	2	141	6	346
4:15	2	216	4	114	6	330
4:30	4	221	11	123	15	344
4:45	5	209	7	107	12	316
5:00	4	224	7	99	11	323
5:15	7	259	14	79	21	338
5:30	19	201	22	98	41	299
5:45	17	175	26	90	43	265
6:00	19	146	32	97	51	243
6:15	27	168	44	89	71	257
6:30	20	134	79	70	99	204
6:45	44	144	88	71	132	215
7:00	58	109	129	51	187	160
7:15	57	102	258	50	309	152
7:30	87	83	214	40	301	123
7:45	134	64	180	27	314	91
8:00	102	84	191	33	293	117
8:15	120	72	141	29	261	101
8:30	132	57	191	38	323	95
8:45	110	57	210	41	320	98
9:00	116	52	157	37	273	89
9:15	101	48	115	25	216	73
9:30	99	50	136	22	235	72
9:45	87	35	172	26	259	61
10:00	89	33	145	28	234	61
10:15	81	34	141	17	222	51
10:30	85	36	155	11	240	47
10:45	119	24	157	8	276	32
11:00	101	13	136	19	237	32
11:15	113	19	164	7	277	26
11:30	117	12	137	8	254	20
11:45	115	15	135	5	250	20
Total	2227	5629	3634	3825	5861	9454
Day Total	7856	7459	15315			

Friday, October 21, 2016						
Hour	NORTH/EAST		SOUTH/WEST		Combined	
	AM	PM	AM	PM	AM	PM
0:00	6	125	7	153	13	278
0:15	8	148	2	156	10	304
0:30	8	162	4	138	12	300
0:45	11	126	3	121	14	247
1:00	5	113	2	116	7	229
1:15	3	134	2	116	5	250
1:30	5	142	3	129	8	271
1:45	1	184	2	118	3	302
2:00	2	133	0	135	2	268
2:15	1	154	1	113	2	267
2:30	0	174	0	152	0	326
2:45	3	166	4	150	7	316
3:00	3	170	0	141	3	311
3:15	0	200	1	165	1	365
3:30	0	191	0	144	0	335
3:45	1	200	5	145	6	345
4:00	1	196	3	145	4	341
4:15	3	221	1	128	4	349
4:30	3	231	9	125	12	356
4:45	3	206	7	111	10	317
5:00	5	227	11	116	16	343
5:15	9	236	18	124	27	360
5:30	10	186	19	82	29	268
5:45	30	178	19	101	49	279
6:00	23	147	21	92	44	239
6:15	20	148	44	96	64	244
6:30	31	108	78	104	109	212
6:45	28	124	93	87	121	211
7:00	47	81	162	56	209	137
7:15	72	99	240	43	312	142
7:30	78	88	193	72	271	160
7:45	124	76	168	41	292	117
8:00	129	73	153	40	282	113
8:15	132	69	161	36	293	105
8:30	116	75	199	31	315	106
8:45	140	45	195	39	334	84
9:00	100	69	183	35	283	104
9:15	93	44	156	31	249	75
9:30	82	46	151	34	233	80
9:45	101	47	143	34	244	81
10:00	84	61	137	26	221	87
10:15	112	41	122	33	234	74
10:30	105	28	137	32	242	60
10:45	97	39	157	18	254	57
11:00	118</					

Saturday, October 22, 2016						
Hour	NORTH/EAST		SOUTH/WEST		Combined	
	AM	PM	AM	PM	AM	PM
0:00	15	126	12	168	27	294
0:15	8	136	7	136	15	272
0:30	14	123	5	127	19	250
0:45	9	150	1	150	10	300
1:00	13	159	6	127	19	286
1:15	3	161	4	144	7	305
1:30	5	125	5	133	10	258
1:45	5	151	2	140	7	291
2:00	5	154	2	155	7	309
2:15	4	149	0	157	4	306
2:30	3	150	2	144	5	294
2:45	0	143	0	135	0	278
3:00	2	183	0	133	2	316
3:15	1	195	1	126	2	321
3:30	0	161	0	128	0	289
3:45	1	139	1	121	2	260
4:00	2	140	0	113	2	253
4:15	1	155	4	125	5	280
4:30	4	153	2	121	6	274
4:45	8	121	6	131	14	252
5:00	8	131	8	105	16	236
5:15	4	123	5	111	9	234
5:30	11	126	11	96	22	222
5:45	15	132	17	121	32	253
6:00	25	111	11	91	36	202
6:15	15	88	36	96	51	184
6:30	19	79	31	70	50	149
6:45	28	84	32	59	60	143
7:00	36	73	37	71	73	144
7:15	40	64	49	56	89	120
7:30	46	68	52	51	98	119
7:45	57	64	75	58	132	122
8:00	49	65	73	39	122	104
8:15	69	62	81	39	150	101
8:30	85	55	124	30	209	85
8:45	96	45	129	28	225	73
9:00	87	52	125	37	212	89
9:15	91	51	124	49	215	100
9:30	81	45	173	41	254	86
9:45	92	48	174	37	266	85
10:00	103	43	160	30	263	73
10:15	120	50	151	36	271	86
10:30	95	28	160	47	255	75
10:45	95	40	178	52	273	92
11:00	113	46	199	36	311	82
11:15	112	49	182	31	294	80
11:30	126	46	156	20	282	66
11:45	107	19	140	16	247	35
Total	1928	4861	2753	4267	4681	9128
Day Total	6789	7020	13809			

Sunday, October 23, 2016						
Hour	NORTH/EAST		SOUTH/WEST		Combined	
	AM	PM	AM	PM	AM	PM
0:00	10	127	10	141	20	268
0:15	20	133	7	118	27	251
0:30	9	123	5	151	14	274
0:45	15	143	7	114	22	257
1:00	16	136	6	111	22	247
1:15	10	138	6	127	16	265
1:30	5	105	3	134	8	239
1:45	2	124	4	132	6	256
2:00	5	124	2	109	7	233
2:15	5	127	2	115	7	242
2:30	2	125	2	128	4	253
2:45	4	137	2	94	6	231
3:00	2	134	1	104	3	238
3:15	1	134	2	112	3	246
3:30	0	117	0	124	0	241
3:45	2	118	0	96	2	214
4:00	3	123	4	95	7	218
4:15	2	141	3	98	5	239
4:30	1	114	3	90	4	204
4:45	8	107	9	93	17	200
5:00	5	98	7	109	12	207
5:15	6	103	6	127	12	230
5:30	8	133	8	88	16	221
5:45	15	115	9	70	24	185
6:00	6	75	5	57	11	132
6:15	13	71	8	50	21	121
6:30	13	79	29	47	42	126
6:45	21	64	14	53	35	117
7:00	24	74	29	46	53	120
7:15	19	57	30	29	49	86
7:30	36	50	43	28	79	78
7:45	46	46	48	29	94	75
8:00	41	34	47	31	88	65
8:15	48	37	62	28	110	65
8:30	45	42	74	22	119	64
8:45	69	32	89	27	158	59
9:00	69	31	95	25	164	56
9:15	68	37	117	26	185	63
9:30	76	26	125	27	201	53
9:45	102	23	129	24	231	47
10:00	69	25	120	17	189	42
10:15	91	12	132	17	223	29
10:30	95	7	129	11	224	18
10:45	107	14	149	21	256	35
11:00	87	9	135	14	222	23
11:15	107	11	127	10	234	21
11:30	96	1	162	10	258	11
11:45	125	13	141	7	275	20
Total	1629	3849	2147	3336	3776	7185
	5478	5483	10961			

Monday, October 24, 2016						
Hour	NORTH/EAST		SOUTH/WEST		Combined	
	AM	PM	AM	PM	AM	PM
0:00	3	111	7	140	10	251
0:15	8	101	3	116	11	217
0:30	6	114	3	114	9	228
0:45	3	115	2	139	5	254
1:00	2	111	0	118	2	229
1:15	1	138	4	124	5	262
1:30	0	128	1	120	1	248
1:45	1	133	2	108	3	241
2:00	2	128	1	128	3	256
2:15	0	121	1	110	1	231
2:30	0	156	0	137	0	293
2:45	0	127	2	129	2	256
3:00	1	140	0	118	1	258
3:15	1	184	2	135	3	319
3:30	0	185	2	132	2	317
3:45	1	187	1	91	2	278
4:00	2	184	7	135	9	319
4:15	2	178	2	109	4	287
4:30	2	223	6	102	8	325
4:45	2	185	10	108	12	293
5:00	7	193	14	98	21	291
5:15	8	182	11	110	19	292
5:30	19	178	17	99	36	277
5:45	19	162	33	98	52	260
6:00	19	142	30	85	49	227
6:15	27	138	46	67	73	205
6:30	33	134	63	61	96	195
6:45	49	104	102	52	151	156
7:00	51	75	133	30	184	105
7:15	63	74	256	36	319	110
7:30	87	78	197	30	284	108
7:45	124	70	194	22	318	92
8:00	115	83	136	24	251	107
8:15	106	75	160	25	266	100
8:30	96	56	199	22	295	78
8:45	132	36	239	23	311	59
9:00	106	39	144	23	250	62
9:15	92	46	136	14	228	60
9:30	71	28	153	9	224	37
9:45	94	30	130	13	224	43
10:00	87	16	115	7	202	23
10:15	100	21	133	12	233	33
10:30	80	11	133	9	213	20
10:45	112	12	116	14	228	26
11:00	94	6	123	7	217	13
11:15	106	9	129	7	235	16
11:30	82	9	123	8	205	17
11:45	101	5	112	3	213	8
Total	2117	4961	3433	3421	5550	8382
	7078	6854	13932			

List of Acronyms

- ADT = Average Daily Traffic
- PH = Peak Hour
- VPD = Vehicles per Day
- CVMP = Carmel Valley Master Plan

Key

AM Count Data
AM Peak Hour
PM Count Data
PM Peak Hour



Monterey County Resource Management Agency - Public Works

Carmel Valley Road Data Sheet

Carmel Valley Road
 Segment 7 - Schulte Road to Rancho San Carlos Road
 Count Location No. 192 - West of Carmel Meadows Road
 Dates: 10/18/2016 to 10/24/2016
 Sheet 1

Tuesday, October 18, 2016						
Hour	NORTH/EAST		SOUTH/WEST		Combined	
	AM	PM	AM	PM	AM	PM
0:00	3	122	7	132	10	254
0:15	7	132	5	137	12	269
0:30	3	129	2	148	5	277
0:45	4	131	3	153	7	284
1:00	3	127	0	137	3	264
1:15	3	127	0	125	3	252
1:30	2	136	2	112	4	248
1:45	3	145	0	116	3	261
2:00	1	158	1	143	2	301
2:15	2	161	1	132	3	293
2:30	1	165	2	151	3	316
2:45	1	181	3	131	4	312
3:00	7	186	0	161	7	347
3:15	1	183	2	183	3	366
3:30	3	193	2	154	5	347
3:45	3	200	0	116	3	316
4:00	2	217	4	151	6	368
4:15	1	207	2	136	3	343
4:30	5	223	7	126	12	349
4:45	5	224	8	144	13	368
5:00	4	245	10	129	14	374
5:15	13	217	18	120	31	337
5:30	19	213	20	107	39	320
5:45	26	194	35	111	61	305
6:00	25	193	33	106	58	299
6:15	32	152	46	110	78	262
6:30	26	141	76	70	102	211
6:45	56	148	79	64	135	212
7:00	64	96	136	74	200	170
7:15	110	105	294	63	404	168
7:30	124	74	239	41	363	115
7:45	168	84	168	24	336	108
8:00	131	60	208	48	339	108
8:15	119	57	173	27	292	84
8:30	133	47	212	19	345	66
8:45	113	54	255	20	368	74
9:00	110	62	183	23	293	85
9:15	108	43	182	21	290	64
9:30	107	46	160	12	267	58
9:45	103	35	145	14	248	49
10:00	76	32	164	13	240	45
10:15	98	18	147	19	245	37
10:30	107	11	136	15	243	26
10:45	130	19	131	11	261	30
11:00	120	13	142	11	262	24
11:15	103	8	130	4	233	12
11:30	121	16	150	5	271	21
11:45	123	8	152	4	275	12
Total	2529	5738	3875	4073	6404	9811
Day Total	8267	7948	16215			

Wednesday, October 19, 2016						
Hour	NORTH/EAST		SOUTH/WEST		Combined	
	AM	PM	AM	PM	AM	PM
0:00	2	137	6	135	8	272
0:15	2	134	4	137	6	271
0:30	4	143	2	147	6	290
0:45	4	133	6	142	10	275
1:00	3	129	0	111	3	240
1:15	0	147	0	136	0	283
1:30	0	145	1	132	1	277
1:45	1	141	1	116	2	257
2:00	0	139	0	140	0	279
2:15	1	166	1	116	2	282
2:30	1	139	0	159	1	298
2:45	1	202	1	140	2	342
3:00	1	197	1	140	2	337
3:15	1	214	1	183	2	399
3:30	1	202	0	147	1	347
3:45	0	205	3	161	3	366
4:00	7	250	3	112	10	362
4:15	5	226	7	121	12	347
4:30	3	226	8	136	11	362
4:45	6	275	7	117	13	392
5:00	6	243	13	126	19	369
5:15	11	215	8	120	19	335
5:30	15	269	24	129	39	398
5:45	24	202	32	101	56	303
6:00	26	176	37	94	63	270
6:15	21	176	53	92	74	268
6:30	46	151	62	68	108	219
6:45	47	139	95	84	142	223
7:00	65	102	133	49	198	151
7:15	98	83	293	58	391	141
7:30	123	92	235	47	358	139
7:45	157	78	203	46	360	124
8:00	136	86	189	55	325	141
8:15	121	85	179	50	300	135
8:30	106	73	200	48	306	121
8:45	132	58	251	53	383	111
9:00	93	44	191	26	284	70
9:15	102	58	155	43	257	101
9:30	116	41	165	27	281	68
9:45	80	19	189	17	269	36
10:00	80	31	151	34	231	65
10:15	118	18	166	21	284	39
10:30	100	16	154	26	254	42
10:45	113	15	142	11	255	26
11:00	119	10	156	12	275	22
11:15	121	13	145	6	266	19
11:30	126	13	152	5	278	18
11:45	122	17	153	2	275	19
Total	2467	6073	3978	4178	6445	10251
Day Total	8540	8156	16696			

Thursday, October 20, 2016						
Hour	NORTH/EAST		SOUTH/WEST		Combined	
	AM	PM	AM	PM	AM	PM
0:00	7	145	5	142	12	287
0:15	6	131	6	150	12	281
0:30	1	141	4	161	5	302
0:45	3	138	3	147	6	285
1:00	3	110	3	142	6	252
1:15	2	135	2	130	4	265
1:30	0	129	3	151	3	280
1:45	3	139	3	142	6	281
2:00	2	144	3	176	5	320
2:15	1	174	1	156	2	330
2:30	1	178	2	150	3	328
2:45	2	194	1	121	3	315
3:00	2	199	1	145	3	344
3:15	1	181	1	173	2	354
3:30	2	183	1	170	3	353
3:45	3	234	1	121	4	355
4:00	5	224	3	146	8	370
4:15	5	219	5	126	10	345
4:30	7	234	7	136	14	370
4:45	4	225	12	138	16	363
5:00	3	267	7	113	10	380
5:15	11	261	12	107	23	368
5:30	19	216	27	111	46	327
5:45	19	188	32	107	51	295
6:00	21	171	29	112	50	283
6:15	34	177	55	95	89	272
6:30	28	135	71	70	99	205
6:45	58	158	87	68	145	226
7:00	69	113	132	56	201	169
7:15	76	117	265	48	341	165
7:30	118	91	246	43	364	134
7:45	192	79	192	31	384	110
8:00	105	88	248	45	353	133
8:15	134	80	165	26	299	106
8:30	140	72	199	37	339	109
8:45	137	64	210	38	347	102
9:00	107	63	175	38	282	101
9:15	103	57	153	22	256	79
9:30	112	59	149	24	261	83
9:45	96	43	182	25	278	68
10:00	89	36	157	33	246	69
10:15	96	36	159	12	255	48
10:30	102	39	154	18	256	57
10:45	120	23	185	23	305	46
11:00	124	13	154	27	278	40
11:15	109	16	175	12	284	28
11:30	136	11	146	9	282	20
11:45	141	15	134	7	275	22
Total	2559	6145	3967	4280	6526	10425
Day Total	8704	8247	16951			

Friday, October 21, 2016						
Hour	NORTH/EAST		SOUTH/WEST		Combined	
	AM	PM	AM	PM	AM	PM
0:00	8	152	7	149	15	301
0:15	8	174	6	166	14	340
0:30	10	150	3	152	13	302
0:45	9	139	4	143	13	282
1:00	5	121	5	133	10	254
1:15	4	166	2	131	6	297
1:30	4	149	4	134	8	283
1:45	1	172	2	124	3	296
2:00	2	142	0	142	2	284
2:15	1	190	1	112	2	302
2:30	0	186	1	165	1	351
2:45	3	195	4	165	7	360
3:00	3	192	0	164	3	356
3:15	1	222	1	197	2	419
3:30	0	211	0	154	0	365
3:45	4	223	3	174	7	397
4:00	1	220	5	150	6	370
4:15	2	232	2	148	4	380
4:30	4	225	10	147	14	372
4:45	5	230	8	133	13	363
5:00	7	239	12	117	19	356
5:15	14	256	18	136	32	392
5:30	11	189	20	85	31	274
5:45	35	195	26	110	61	305
6:00	25	162	27	107	52	269
6:15	26	149	40	96	66	245
6:30	40	115	86	103	126	218
6:45	50	140	89	90	139	230
7:00	61	92	155	48	216	140
7:15	91	116	281	49	372	165
7:30	113	89	221	67	334	156
7:45	168	80	162	53	330	133
8:00	159	64	188	52	347	116
8:15	126	77	187	49	313	126
8:30	138	65	187	36	325	101
8:45	147	62	212	35	359	97
9:00	112	80	193	41	305	121
9:15	95	51	189	36	284	87
9:30	87	58	177	32	264	90
9:45	109	54	169	33	278	87
10:00	82	71	145	29	227	100
10:15	117	42	144	38	261	80
10:30	111	35	153	38	264	73
10:45	118	44	159	24	277	68
11:00	132	30	166	19	298</	

Saturday, October 22, 2016							Sunday, October 23, 2016							Monday, October 24, 2016						
Hour	NORTH/EAST		SOUTH/WEST		Combined		Hour	NORTH/EAST		SOUTH/WEST		Combined		Hour	NORTH/EAST		SOUTH/WEST		Combined	
	AM	PM	AM	PM	AM	PM		AM	PM	AM	PM	AM	PM		AM	PM	AM	PM	AM	PM
0:00	16	154	15	161	31	315	0:00	16	134	14	161	30	295	0:00	9	119	14	152	23	271
0:15	10	167	8	157	18	324	0:15	28	123	11	152	39	275	0:15	7	109	5	127	12	236
0:30	17	157	6	142	23	299	0:30	8	144	5	167	13	311	0:30	6	116	3	136	9	252
0:45	9	165	0	161	9	326	0:45	16	134	7	138	23	272	0:45	2	130	3	138	5	268
1:00	12	179	5	132	17	311	1:00	14	147	6	127	20	274	1:00	3	120	0	141	3	261
1:15	3	157	3	158	6	315	1:15	11	142	9	133	20	275	1:15	0	151	4	133	4	284
1:30	4	134	5	165	9	299	1:30	5	129	5	154	10	283	1:30	0	132	1	138	1	270
1:45	8	164	3	171	11	335	1:45	3	127	4	133	7	260	1:45	2	149	3	115	5	264
2:00	5	160	3	164	8	324	2:00	5	133	2	123	7	256	2:00	2	138	1	137	3	275
2:15	4	160	1	163	5	323	2:15	6	139	3	130	9	269	2:15	0	144	0	132	0	276
2:30	3	172	2	160	5	332	2:30	3	139	1	152	4	291	2:30	0	158	1	176	1	334
2:45	1	180	0	162	1	342	2:45	3	137	3	116	6	253	2:45	0	149	3	133	3	282
3:00	2	185	1	174	3	359	3:00	2	145	1	120	3	265	3:00	2	180	0	118	2	298
3:15	1	199	3	157	4	356	3:15	2	133	1	132	3	265	3:15	1	192	3	178	4	370
3:30	1	164	3	159	4	323	3:30	1	122	0	134	1	256	3:30	0	202	2	158	2	360
3:45	3	158	1	139	4	297	3:45	2	133	1	114	3	247	3:45	2	207	1	119	3	326
4:00	1	145	0	127	1	272	4:00	3	131	4	100	7	231	4:00	1	203	9	138	10	341
4:15	4	161	3	145	7	306	4:15	4	137	5	117	9	254	4:15	2	213	4	131	6	344
4:30	3	150	1	132	4	282	4:30	4	135	3	98	7	233	4:30	6	219	8	105	14	324
4:45	9	137	6	137	15	274	4:45	8	117	12	102	20	219	4:45	4	204	9	125	13	329
5:00	8	141	9	120	17	261	5:00	6	101	7	113	13	214	5:00	6	205	17	99	23	304
5:15	9	149	4	110	13	259	5:15	10	105	6	119	16	224	5:15	12	214	11	124	23	338
5:30	12	140	11	114	23	254	5:30	13	160	7	90	20	250	5:30	22	183	23	107	45	290
5:45	19	138	17	125	36	263	5:45	17	135	8	84	25	219	5:45	21	196	31	112	52	308
6:00	23	114	10	93	33	207	6:00	8	91	6	70	14	161	6:00	20	160	30	91	50	251
6:15	18	110	32	93	50	203	6:15	17	85	12	57	29	142	6:15	32	153	54	66	86	219
6:30	26	77	41	75	67	152	6:30	18	92	27	56	45	148	6:30	37	147	59	63	96	210
6:45	33	86	40	87	73	173	6:45	27	77	21	55	48	132	6:45	66	108	105	52	171	160
7:00	36	96	32	73	68	169	7:00	20	82	32	45	52	127	7:00	60	82	116	33	176	115
7:15	58	63	50	62	108	125	7:15	20	67	30	29	50	96	7:15	85	90	305	41	390	131
7:30	56	67	60	61	116	128	7:30	38	52	41	25	79	77	7:30	118	87	232	39	350	126
7:45	56	70	77	56	133	126	7:45	45	54	60	34	105	88	7:45	173	70	189	26	362	96
8:00	56	69	82	55	138	124	8:00	44	41	53	33	97	74	8:00	133	101	188	25	321	126
8:15	64	64	90	52	154	116	8:15	47	39	69	30	116	69	8:15	117	76	194	33	311	109
8:30	84	56	142	31	226	87	8:30	58	47	87	23	145	70	8:30	87	53	212	26	299	79
8:45	104	57	143	35	247	92	8:45	69	35	90	24	159	59	8:45	140	43	222	25	362	68
9:00	87	62	125	43	212	105	9:00	79	37	96	21	175	58	9:00	107	47	174	23	281	70
9:15	113	52	133	50	246	102	9:15	76	36	112	29	188	65	9:15	85	52	159	19	244	71
9:30	95	46	170	49	265	95	9:30	84	28	135	24	219	52	9:30	86	31	171	12	257	43
9:45	110	59	190	36	300	95	9:45	138	31	133	30	271	61	9:45	102	29	158	12	260	41
10:00	121	46	168	38	289	84	10:00	90	21	125	18	215	39	10:00	92	22	132	13	224	35
10:15	130	46	171	34	301	80	10:15	119	12	155	17	274	29	10:15	109	20	159	11	268	31
10:30	122	36	173	56	295	92	10:30	116	8	136	18	252	26	10:30	96	13	136	11	232	24
10:45	113	55	162	54	275	109	10:45	113	13	162	24	275	37	10:45	134	9	119	15	253	24
11:00	147	47	209	47	356	94	11:00	99	10	133	13	232	23	11:00	112	11	135	8	247	19
11:15	142	62	192	35	334	97	11:15	107	10	153	12	260	22	11:15	114	9	125	8	239	17
11:30	143	46	178	21	321	67	11:30	119	4	174	10	293	14	11:30	102	12	139	7	241	19
11:45	153	22	156	19	309	41	11:45	115	15	168	5	283	20	11:45	111	6	136	5	247	11
Total	2254	5324	2936	4790	5190	10114	1856	4169	2335	3711	4191	7880	2428	5464	3805	3836	6233	9300		
Day Total	7578	7726	15304				6025	6046	12071				7892	7641	15533					

List of Acronyms

- ADT = Average Daily Traffic
- PH = Peak Hour
- VPD = Vehicles per Day
- CVMP = Carmel Valley Master Plan

Key

AM Count Data
AM Peak Hour
PM Count Data
PM Peak Hour